

Best Hoist

Pro-3 Series Davit System / Pro-3 HD Series Davit System

OPERATOR'S MANUAL



Man-Rated for:

Work Positioning

Confined Space Entry / Retrieval

Rescue

Fall Protection

Also Rated for Material Handling Applications

TABLE OF CONTENTS

1. INTRODUCTION to DAVIT SYSTEM APPLICATIONS
2. APPLICATION RESTRICTIONS
3. GENERAL SYSTEM REQUIREMENTS
4. PRO-3 DAVIT SYSTEM SET-UP and OPERATION
5. TRAINING
6. INSPECTION
7. MAINTENANCE LUBRICATION and STORAGE
8. SPECIFICATIONS

1. INTRODUCTION to DAVIT ARM APPLICATIONS

Congratulations on your purchase of a Best Safety Systems Pro-3 / Pro-3 HD Series Davit System as part of your Safety-at-Heights equipment. Please see Figure 1 below for names and locations of system components.

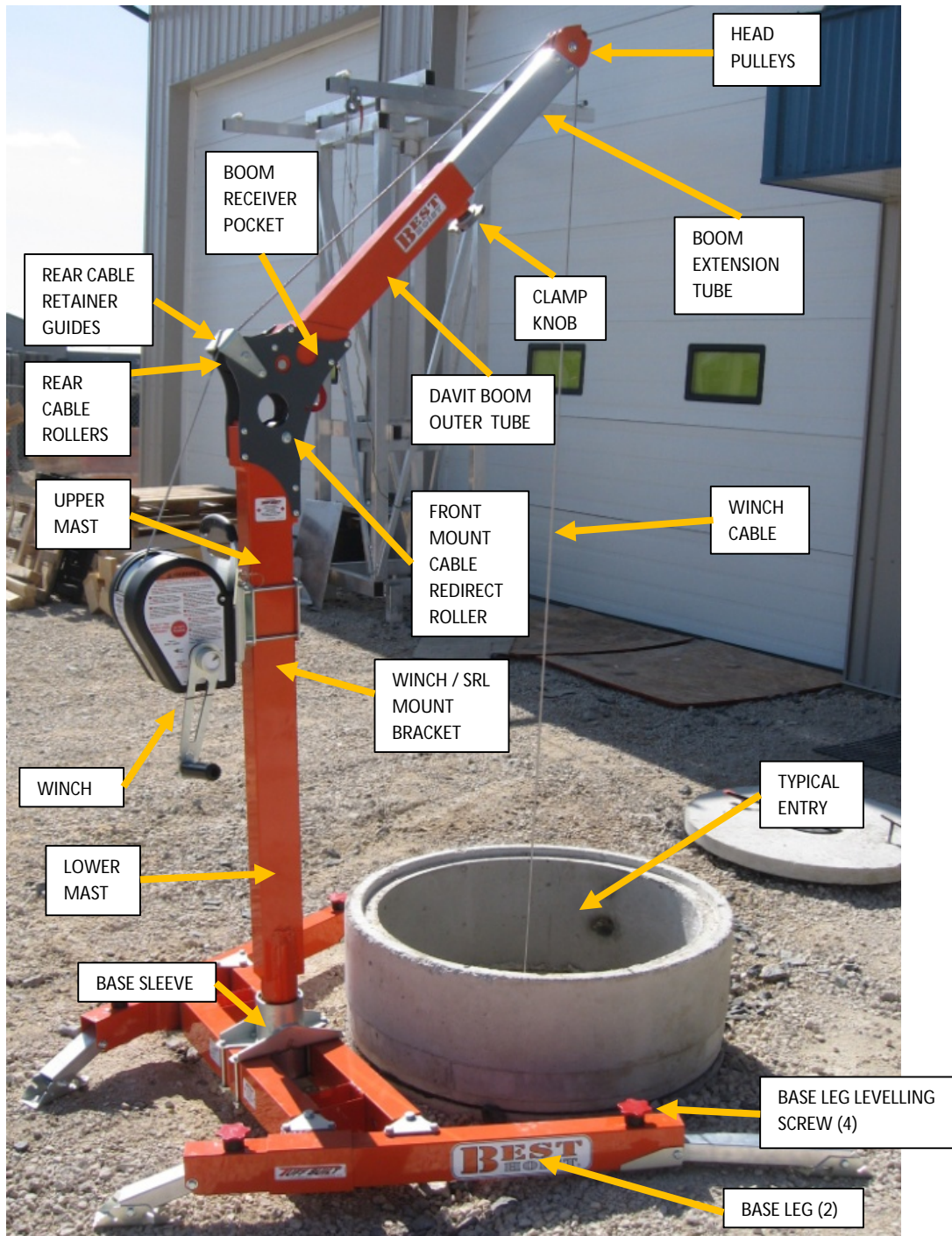

Figure 1, Pro-3 Davit System Parts and Location (Pro-3 HD is Similar)

The Pro-3 Davit Arm is constructed of high quality aluminum tubing for light weight, and features patented Tuff-Klik pin-less connections for easy of set-up and tear-down.

The Pro-3 Davit Arm may be equipped with a variety of Pro-Series bases, winches, self-retracting lifelines, and other accessories to meet your needs.

This product has been specifically designed and carefully manufactured to provide reliable operation in many different safety-at-heights applications. These include, but are not limited to, various combinations of:

1.1 FALL PROTECTION

The Pro-3 Davit Arm is designed to be used with a variety of mounting base options to provide an engineered supporting structure for Personal Fall Arrest Systems (PFAS). Additionally, with the addition of a winch, the Davit Arm may be used as a rescue device to assist with the rescue of a worker who has fallen and is being suspended by his/her PFAS.

1.2 WORK POSITIONING

The Pro-3 Davit Arm may also be equipped with a winch to be used for the suspension of a worker at an elevated position for the performance of a task. When a worker is suspended in a work seat or harness, a secondary personal fall arrest system must be used which meets applicable OSHA or other local requirements.

NOTE: OSHA 29 CFR 1926 Subpart L considers this application to be a single point suspension scaffold, and requires treatment as such.

1.3 RESCUE

The Pro-3 Davit Arm, base, and winch may be used employed as part of a system meeting the requirements of ANSI/ASSE Z359.4 for the rescue of a fallen worker.

1.4 CONFINED SPACE ENTRY / RETRIEVAL and RESCUE

The Pro-3 Davit Arm, base, and winch, may be used as part of a system to facilitate access to and egress from a confined space as well as non-entry rescue in the event of an emergency. When used with an approved Tuff Built Products mounting base and winch, the Pro-3 Davit System meets the requirements of OSHA 1910.146, and ANSI/ASSE Z117.1 for use as a confined space entry/retrieval and rescue device.

1.5 FALL PROTECTION WHILE CLIMBING

In situations where it is not practical to install and use a temporary or permanently installed personal fall arrest system, the Pro-3 Davit Arm may be combined with a suitable Tuff Built Products mounting base and winch to guard against falling while climbing a ladder or other structure. The winch line can be used an extendable anchorage connector that moves up and down with the climber. An energy absorbing

lanyard installed between the winch line and the dorsal D-ring on the climber's full body harness absorbs fall energy and reduces the arresting forces in the event of a fall. The winch must be operated so as to continuously eliminate any slack in the winch line as the climber moves up and down. The winch operator must be specifically instructed in such use of this equipment. All such installations must be designed, installed, and used under the supervision of a qualified person.

1.6 MATERIAL HANDLING

The Pro-3 Davit Arm, when combined with a suitable Tuff Built Products mounting base and winch, may be used for the raising and lowering of tools, equipment, and other material not exceeding the rated Working Load Limit of any system component.

NOTE: Some jurisdictions may not allow the use of the same equipment to move personnel and material. Be aware of and follow the regulations governing your workplace.

2. APPLICATION RESTRICTIONS

There are restrictions and limitations that must be carefully considered in the selection, installation, and operation of this type of equipment. Serious injury or death may result from failure to consider these factors.

2.1 WORKING LOAD LIMIT

The Pro-3 Davit Arm is designed and rated for a working load limit of 1 person weighing a maximum of 310lbs (including all clothing, tools, and equipment) when used in a 1 Part Single Reeved System as shown in Figure 2.

1 Part single reeved system

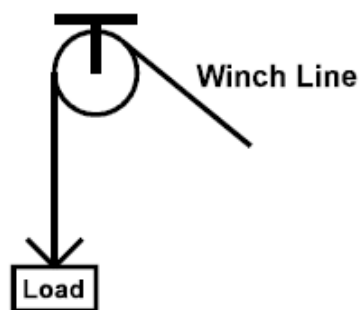

Figure 2, Typical 1 Part Single Reeved System

In a Rescue situation or other application requiring the raising and/or lowering of 2 persons each weighing a maximum of 310lbs (including all clothing, tools, and equipment), configuring the equipment as a 2 Part Single Reeved System (see Figure 3) allows a working load up to 620 lb.

2 Part single reeved system

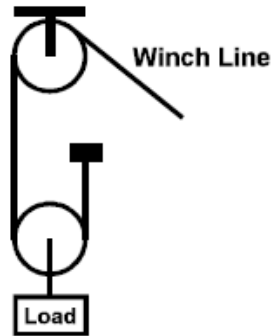

Figure 3, Typical 2 Part Single Reeved System

For a 2 Part Single Reeved System, the winch line is passed through a travelling pulley connected to the load, and then anchored back to the davit as shown in Figure 4.



Fig. 4a



Fig. 4b



Fig. 4c



Fig. 4d

Figure 4; 2 Part Single Reeved Winch Installation on Pro-3 Davit (Pro-3 HD is Similar)

This doubles the mechanical advantage but also doubles the length of cable required for a given working distance. A 2 Part Single Reeved System is rated for a higher working load limit, but be aware that raising/lowering speed is only half that of a 1 Part Single Reeved System.

Note: The Pro-3 Davit must only be used in a 2 Part Single Reeved configuration in the fully retracted davit offset position (See Figure 4a). Attempting to raise 620 lbs in the extended

position will result in activation of the Overload Indicator and retraction of the Boom Extension Tube.

2.2 SITE CHARACTERISTICS, PHYSICAL and ENVIRONMENTAL FACTORS

Individual work sites have associated with them any of a number of hazards related to the site itself and the activities being carried out at that site. These may include, but are not limited to poisonous or explosive atmospheric conditions, poisonous or corrosive chemical hazards, hot surfaces, electrical hazards, sharp edges, engulfment hazards, or moving machinery.

All of these factors must be taken into consideration when selecting equipment for a given application.

3. GENERAL SYSTEM REQUIREMENTS

The Pro-3 Davit Arm is designed for use with a variety of accessories to perform many functions. There are basic requirements common to all such systems that include, but are not limited to, the following.

3.1 ANCHORAGE STRENGTH

The Pro-3 Davit Arm is designed to be set up or installed, and used on a supporting surface (anchorage) capable of providing sufficient anchorage strength to support all applied loads with an acceptable margin of safety. The standards governing different situations specify various minimum requirements depending on the application, the work being performed, and other factors.

However, at no time shall the anchorage provide any less than the greater of:

- a 2:1 safety factor on the maximum arrest force (MAF) rating of any fall arrest system being used,
- a 4:1 safety factor on personnel working loads applied to the system,
- a 4:1 safety factor on material handling loads applied to the system.

All installations **MUST BE** used under the supervision of a Qualified Person.

3.2 COMPATIBILITY OF CONNECTORS

Connectors used to connect components in the system must be compatible with each other to ensure sufficient strength and eliminate the risk of accidental disengagement or rollout during use. Connectors supplied with products designed, manufactured, and/or approved by Tuff Built Products Inc. will meet applicable compatibility requirements for connectors. Any connectors not supplied by Tuff Built Products Inc. **MUST BE** approved by a Qualified Person, and installed, inspected, and used according to the respective manufacturer's instructions.

3.3 FULL BODY HARNESS

Use only a full body harness designed, tested, and approved for fall arrest when connecting a person to this winch. Body belts or straps do not provide adequate support to the body to prevent serious injury or death in the event of a fall.

3.4 FALL PROTECTION

Activities involving working at heights require the use of equipment to protect the worker in the event of a fall. Suitable fall protection must be provided as required by applicable local regulations when using the Pro-3 Davit System and related equipment.

3.5 CONFINED SPACE SAFETY

When the Pro-3 Davit Arm is used as part of a system involving work in a confined space, always follow an approved confined space safety plan meeting all local regulations.

3.6 SWING ANGLE

Care must be taken at all times to minimize the potential for swing fall when working at heights. At no time should the angle of a winch or SRL line exceed 5 degrees with respect to the vertical (see Figure 5).

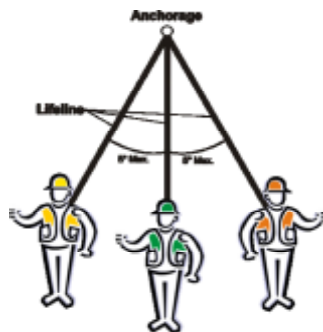

Figure 5, Maximum Swing Angle

4.0 PRO-3 DAVIT SYSTEM SETUP and OPERATION

The Pro-3 Davit Arm is designed for use in conjunction with various accessories to meet different requirements. These may include winches, davits, self-retracting lifelines (SRL's), energy absorbers, and full-body harnesses. All installations must be approved by a Qualified Person.

4.1 SET-UP / INSTALLATION OF MOUNTING BASES

The Pro-3 Davit Arm is designed for use in many types of bases depending on the given application, including service vehicle tow hitch mounted bases, barrel mount bases, counterweighted bases, and various styles of clamp-on and permanent mount bases.

Mounting bases must be set up or installed and used on an anchorage meeting the strength requirements as specified in Section 3.1. Bases other than the Tuff Built Products Pro-3 Series Portable

Base shown in Figure 6 must be set up or installed following the Manufacturer's setup or installation instructions provided with each base.

4.2 Pro-3 Series Portable Base

If you are using a Tuff Built Products Pro-3 Series Portable Base with your Pro-3 Davit Arm, assemble the base as shown in Figure 6.

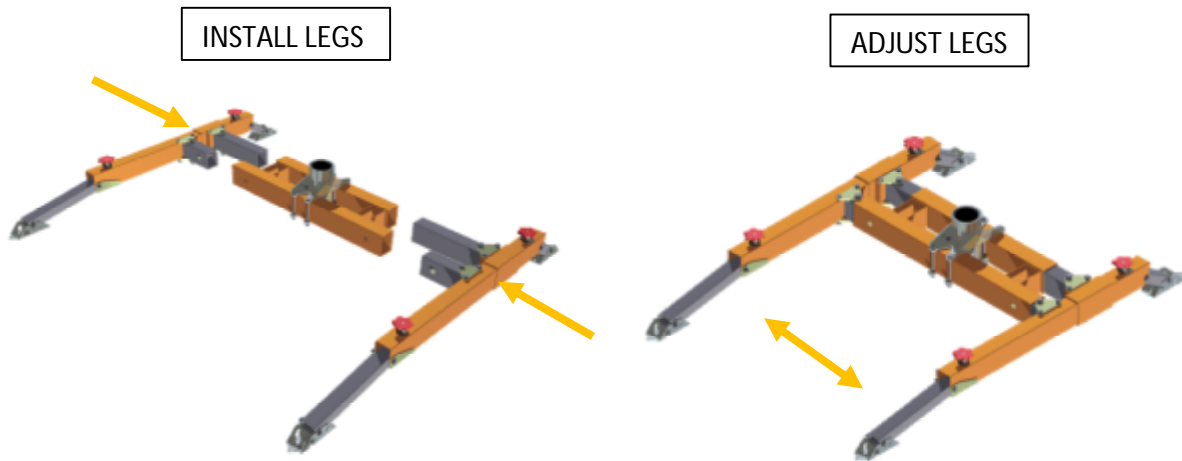

Figure 6, Assembling & Adjusting Pro-3 Portable Base (Pro-3 HD is Similar)

NOTE:

Some bases are shipped from the factory with the base sleeve assembly removed to reduce shipping size as shown in Figure 7.

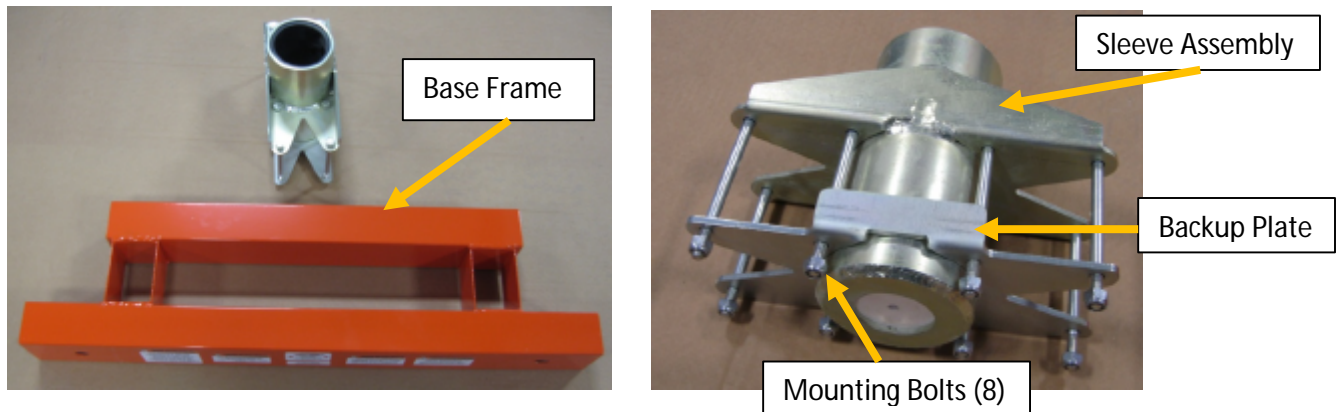

Figure 7, Disassembled Base Frame / Sleeve (Pro-3 HD is Similar)

To install the sleeve assembly, remove the mounting bolts from the Sleeve Assembly, install the sleeve into the Base Frame as shown in Figure 8, and tighten Mounting Bolts being careful not to over-tighten the bolts and crush the tubes.

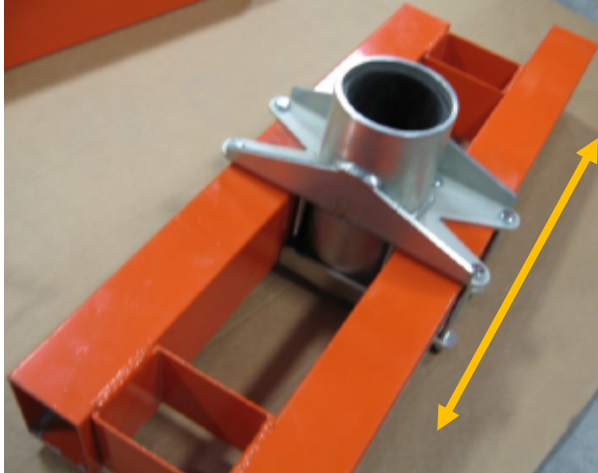

Figure 8, Assembled Base Frame / Sleeve (Pro-3 HD is Similar)

The Sleeve Assembly may be moved side to side if required to adjust the davit position around site obstacles.

For openings larger than 75" in diameter, use the Model 30115 Pro-3 HD Portable Base (see Figure 7).

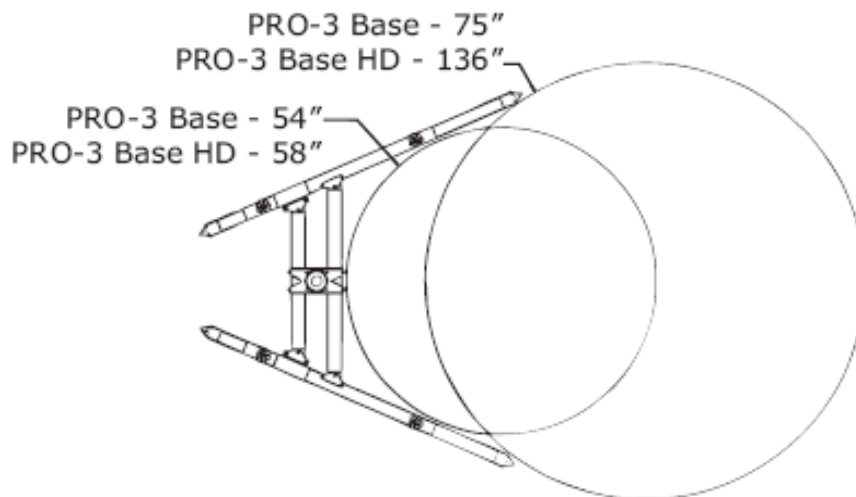

Figure 7, Range of Opening Sizes for Pro-3 and Pro-3 HD Portable Bases

By angling the base legs, position the base around the opening being entered so as to achieve the best access to the opening for the entrant, and the best working position for the attendant.

Level the Base Assembly using the 4 Base Leg Leveling Screws, adjusting the base such that the legs angle slightly upwards as they go from back to front.

4.3 DAVIT INSTALLATION & ADJUSTMENT

Install the davit into the sleeve on the base as shown in Figure 8, and check that the davit rotates freely in the sleeve.

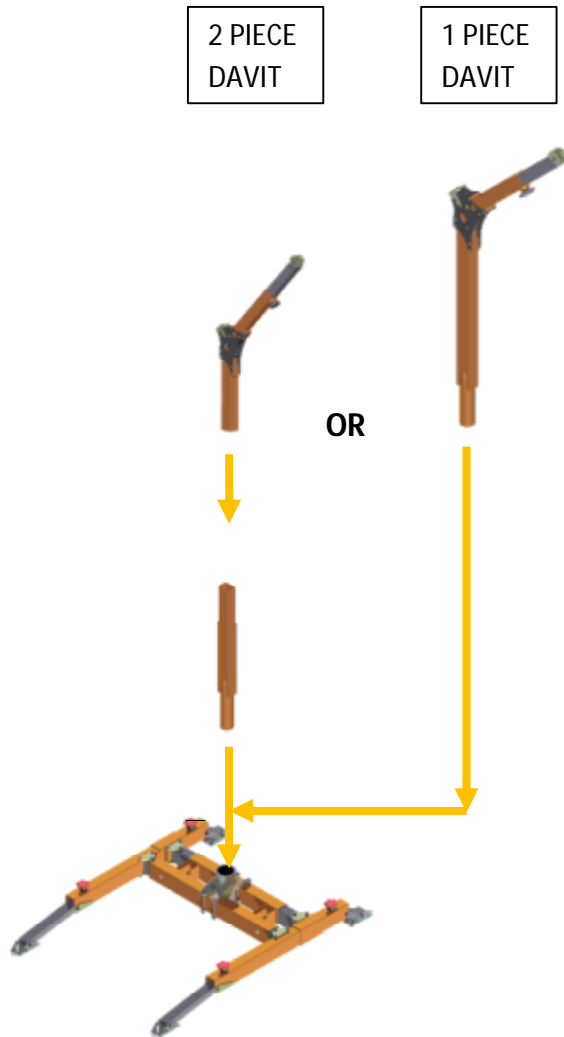

Figure 8, Installation of Pro-I Davit Arm to Pro-III Series Mounting Base (Pro-3 HD is Similar)

Adjust the offset of the davit as required for the job at hand by loosening the Clamp Knob, sliding the Boom Extension Tube to the required position, and tightening the Clamp Knob to lock the Extension Tube in place. Tighten the Clamp Knob until you hear and feel the internal ratchet click at least twice to ensure proper engagement of the Overload Indicator.

Under all normal working loads, the Boom Extension Tube is locked in place when the Clamp Knob is tightened. If system mis-use applies excessive load to the system, the Extension Tube slides back inside the Receiver Tube to effectively shorten the arm and reduce loading to protect other parts of the system. Movement of the Extension Tube under loading indicates that excessive force is being applied to the system, and the activity causing the movement **MUST BE** stopped immediately.

4.4 WINCH, SRL, & ACCESSORY INSTALLATION

Please refer to the Operator's Manual provided with all Tuff Built Products Inc. accessories at the time of purchase for detailed information on the installation of Winches or SRL's onto the Davit System.

If you are using a Tuff Built Pro-Series Winch and / or Tuff Line self retracting lifeline (SRL) with your Davit System:

-Insert the slotted tube on the back of the winch or SRL into receiver tube mounted on the tripod as shown in Figure 9a and 9b.

-Depress the 2 opposing buttons on the Tuff Klik connector, and insert the tube until both buttons engage fully as shown in Figure 9c.

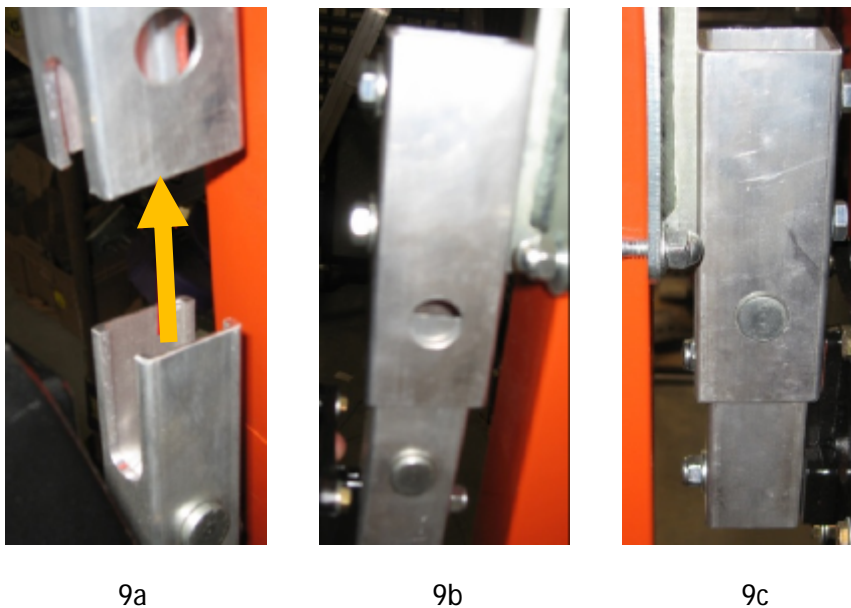

Figure 9, Tuff Built Products Winch / SRL Installation.

On davits equipped with the optional SRL Mounting Anchor Cable (Tuff Built PT# 60182) as shown in Figures 10 & 11, an SRL may be attached as shown using an approved caribiner.

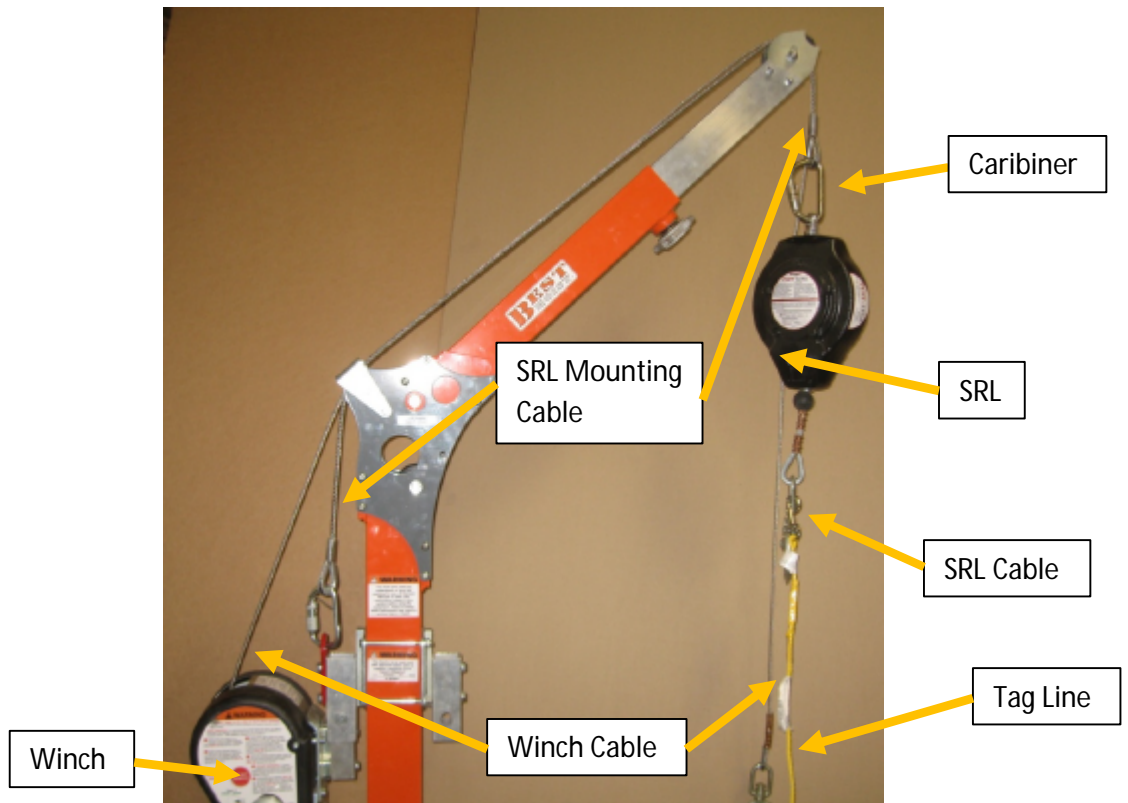

Figure 10, Optional SRL Mounting Anchor Cable Installation

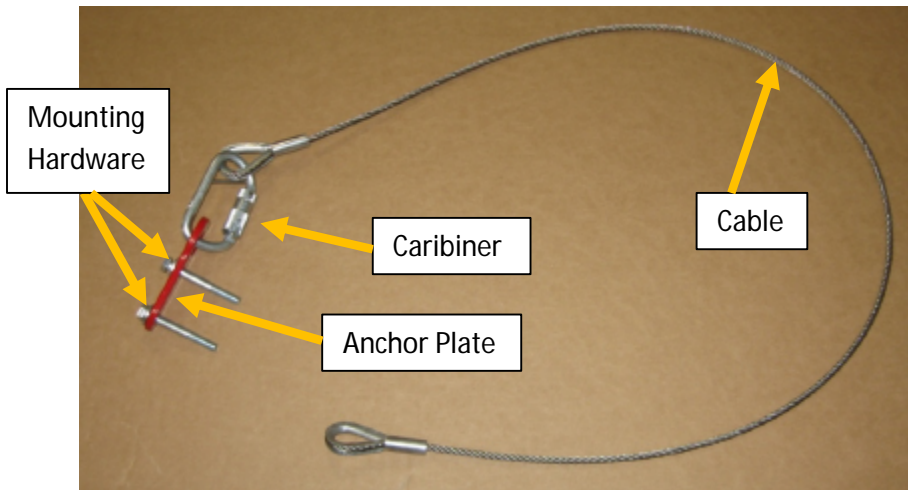

Figure 11, Optional SRL Mounting Anchor Cable Kit

For accessories not supplied by Tuff Built Products Inc., the Qualified Person responsible for the design, installation, and use of the system must provide detailed information regarding the installation of the winch or SRL onto the system.

Install any additional accessories required for the job at hand according to the appropriate Operator's Manual or other user instructions as applicable.

4.5 SYSTEM OPERATION

Once all accessories have been properly installed onto the system, accessory operation is as outlined in the applicable Operator's Manual. Manuals for winches, SRL's, or other accessories provided by Tuff Built Products Inc. are provided with the equipment at time of purchase. Replacement manuals are available from Tuff Built Products Inc. or your local dealer. No person shall use this winch without receiving proper training as outlined in Section 5. Any user must fully read and understand this manual and any other instruction manual(s) related to the system being used, or have the instructions explained to them, before using this equipment.

4.6 INSPECTION

The Pro-3 Davit Arm must be inspected before each use as outlined in Section 6.1.

Any problems must be reported immediately to your supervisor, and the equipment labeled to prevent further use until it has been repaired.

NOTE: Any time a winch is returned to a factory authorized service center for repair, please provide photocopies of all previous Inspection Log sheets for that winch to assist with diagnosis and processing of any warranty claims.

Please obtain a Returned Goods Authorization number from the service center before sending your winch for service.

5. TRAINING

Any worker using this Pro-3 Davit Arm must receive appropriate training from their employer on all equipment involved prior to operating. Users must fully read and understand this manual and any other instruction manual(s) related to the system being used, or have the instructions explained to them, before using this equipment.

6. INSPECTION

6.1 DAILY INSPECTION

The Pro-3 Davit Arm must be inspected before each use as described in Sections 6.1.1 to 6.1.3. Report any problems or concerns to your supervisor, and do not use the equipment until they have approved doing so.

6.1.1 Cleaning and Lubrication

If required, clean and lubricate the Pro-3 Davit Arm and all its parts as outlined in Section 7. Do not use solvents or other chemicals to clean the base.

6.1.2 Physical Damage

Inspect the Pro-3 Davit System and all accessories for physical damage; bent parts, loose or missing hardware or parts, and missing, or illegible labels (see Figure 12). Replacement labels are available from your dealer by ordering the part number shown on each label.

Note: Not all labels shown may be present on your equipment, as some are related to standards and certifications that may not apply to your jurisdiction.

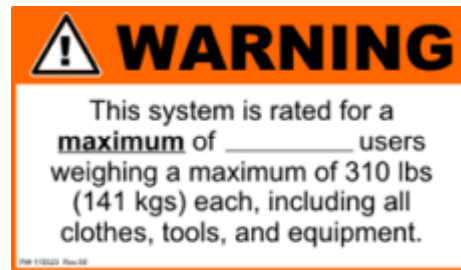
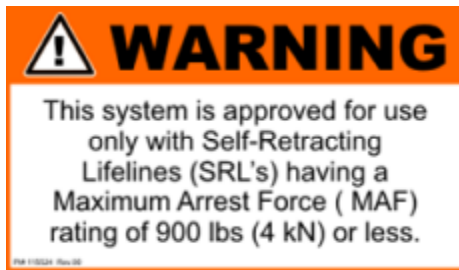

Tuff Built Products Inc. Model:

Date of Manufacture (mm/dd/yy):

Part #:

Serial #:

PW 11528 Rev.02

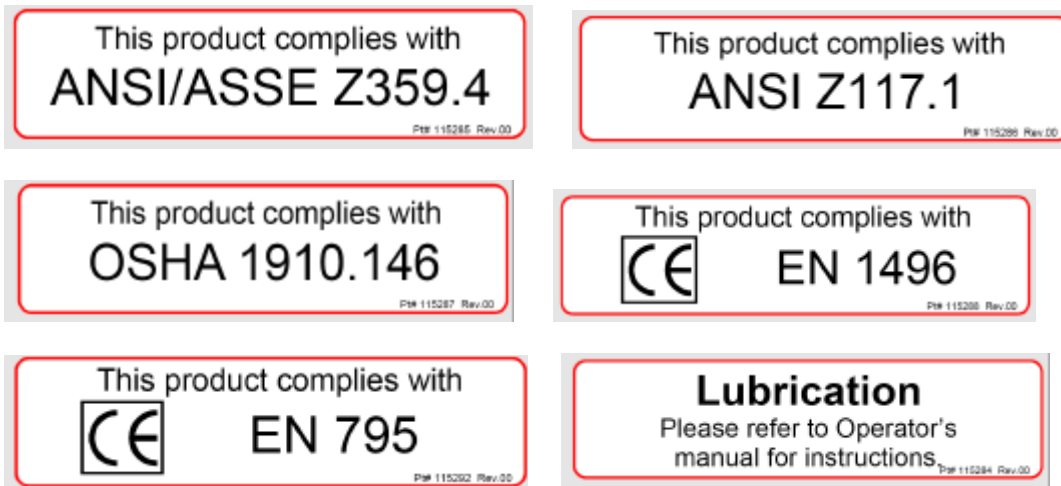

Figure 12, Pro-3 Davit System Labels

While minor cosmetic damage will not affect the structural integrity of the Pro-3 Davit System, seriously damaged equipment **MUST BE** removed from service and returned to an authorized service center for repair prior to further use.

Additionally, inspect any accessories being used with the Davit System as instructed in the Operators Manual provided by the respective manufacturer at the time of purchase.

6.1.3 Davit Overload Indicator Operation

The Pro-3 Davit Arm is equipped with a unique overload protection feature that guards against damage to system components and provides a visual indicator of the structure having been subjected to greater than allowed loading.

Note: Do not test Overload Indicator over an opening or where there is a chance of falling

To inspect the Overload Indicator for proper engagement:

- Fully extend and lock the Boom Extension Tube as described in Section 4.3,
- Install a winch or SRL on the structure as per the applicable instructions, and,
- Pull with your full body weight on the lifeline and make sure there is no movement of the Extension Tube. If using an SRL, apply a sharp, steady pull on the lifeline to engage the SRL brakes, then pull on the lifeline to test the Overload Indicator.

Note: When conducting this test with an SRL, the test should be applied to the lifeline above the snap hook to eliminate any damage over time to any integral overload indicator in the snap itself.

6.2 ANNUAL INSPECTION

At least annually, and more frequently if subjected to harsh conditions or excessive use, the Pro-3 Davit System **MUST BE** given a detailed inspection by a competent person as described below, and the results recorded in an Inspection Log. A sample Inspection Log is provided on Page 16 of this manual. Please make photocopies of this sample to record all inspection results.

Following the instructions for Daily Inspection contained in Section 6.1.1 to 6.1.3, inspect the equipment for physical damage and record the results in the Inspection Log.

IMPORTANT: Be sure to review any previous inspection records to be aware of existing concerns and to allow for re-inspection of any potential problem areas. Cumulative findings may lead to the need for repair or replacement when looked at together.

NOTE: Any time equipment is returned to a factory authorized Service Center for repair, please provide photocopies of all previous Inspection Log sheets for that product to assist with diagnosis and processing of any warranty claims or service issues.

Please obtain a Returned Goods Authorization number from the service center before sending your equipment for service.

7. MAINTENANCE, CLEANING, LUBRICATION and STORAGE

The Pro-3 Davit System has been designed to provide many years of trouble free service, and requires little in the way of routine maintenance.

Any loose fasteners must be tightened, and the equipment returned to a factory authorized service center for structural repair if necessary.

Basic cleaning should be performed at least annually (as outlined in Section 6.2.1) as part of the annual inspection, or more frequently as required when used is under harsh conditions.

7.1 Cleaning the Pro-3 Davit Arm

Use a solution of warm water and a mild detergent to clean the Pro-3 Davit System and its labels. Do not use solvents or other cleaners to clean the equipment, as this may result in damage to the powder coat finish.

7.2 Lubrication

7.2.1 Tuff-Klik Lubrication

After cleaning and inspection as instructed in Section 6.2.3, lubricate Tuff-Klik connectors with WD-40 or a similar moisture displacing penetrant as required, and wipe away any excess with a clean cloth. Do not apply oil, grease, or other lubricants that may attract and trap contaminants.

7.2.2 Sliding Assemblies Lubrication

After cleaning and inspection as instructed in Section 6.2.3, wipe all sliding surfaces with a clean rag dampened with WD-40 or a similar moisture displacing penetrant.

7.3 Storage

Store the Davit Arm and other related safety equipment out of direct sunlight in a cool, dry area away from dust, chemicals or other harmful material. Always inspect before using equipment that has been stored for any extended period of time.

7.4 Parts Considered Normal Wear and Tear for Warranty Purposes

Pulleys, Rollers, Labels, Adjuster Screws, Rubber Foot Pads (where applicable), and Tuff-Klik Connectors are considered subject to normal wear and tear during use and are not covered under warranty except in cases of material or manufacturing defects.

8. DAVIT SYSTEM GENERAL SPECIFICATIONS

8.1 MATERIALS OF CONSTRUCTION

The Pro-3 Davit Arm is principally constructed of powder coated 6061-T6 aluminum.

Steel hardware and connecting brackets are zinc plated and/or powder coated for corrosion resistance. Plating conforms to ASTM B633-85, Type III, SC2.

8.2 COMPONENT WEIGHTS

PRO-3 SERIES PRODUCTS

- Pro-3 Upper Davit Boom Assembly: 8.75 lbs (4.0 kg).
- Pro-3 Upper Davit Arm Post, 28R-54H: 13.45 lbs (6.11 kg).
- Pro-3 Upper Davit Arm, 28R-66H: 15 lbs (6.82 kg).
- Pro-3 Forty Inch Lower Davit Arm: 9.25 lbs (4.20 kg).
- Pro-3 Fifty-Two Inch Lower Davit Arm: 12 lbs (5.45 kg).
- Pro-3 Eighty-four inch 1-Piece Davit Arm, 28R-84H: 20 lbs (9.10 kg).
- Pro-3 One Hundred and Eight inch 1-Piece Davit Arm, 28R-108H: 23 lbs (10.45 kg).
- Tuff-Klik style Winch / SRL bracket for the Pro-3 Davit Arm: 3.4 lbs (1.55kg)
- Pro-3 Series Portable Base Center Section: 18.5 lbs (8.41 kg).
- Pro-3 Series Portable Base Center Leg Assembly (2 per unit): 17 lbs (7.73 kg) each.

PRO-3 HD SERIES PRODUCTS

- Pro-3 HD Upper Davit Boom Assembly: 12 lbs (5.45 kg).
- Pro-3 HD One hundred inch 1-Piece Davit Arm, 42R-100H: 34 lbs (15.45 kg).
- Tuff-Klik style Winch / SRL bracket for the Pro-3 HD Davit Arm: 3.4 lbs (1.55kg)
- Pro-3 HD Series Portable Base Center Section: 35 lbs (15.91 kg).
- Pro-3 HD Series Portable Base Leg: -Rear Assembly (2 per Unit) 19 lbs (8.64 kg) each.
-Front Assembly (2 per Unit) 6.5 lbs (2.95kg) each.

PRO-3 / PRO-3 HD DAVIT SYSTEM INSPECTION LOG

Pro-3 Davit System Model Number: _____

Pro-3 Davit System Serial Number: _____

Date of Manufacture (dd/mm/yy): _____

Purchase Date (dd/mm/yy): _____

INSPECTION ITEM	PASS	FAIL	DETAILS / LOCATION of DAMAGE	DISPOSITION (REPAIRED / SCRAPPED)	APPROVED FOR USE BY
Physical Damage to the Structure					
Damaged, loose, corroded or Missing Hardware or Connectors					
Missing or Illegible Labels					
Sticking or corroded Tuff-Klik connectors or Sliding Tubes					

Date of Inspection: _____

Inspected By: _____