

ALL DIMENSIONS IN mm U.O.S.

DO NOT SCALE DRAWING

### SPECIFICATION

UNLADEN WEIGHT	:-- 710 KGS
GROSS WEIGHT	:-- 3150 KGS
TOW EYE LOAD	:-- 150 KGS (MAX)
AXLE LOAD	:-- 3000 KGS (MAX)
PAYLOAD	:-- 2430 KGS
MAX REEL DIA	:-- 2500 mm
MIN REEL DIA	:-- 1060 mm
MAX REEL WIDTH	:-- 1280 mm (WITH COLLARS)
SPINDLE DIA	:-- 76 mm
TYRES & WHEELS	:-- 215/75 R17.5
DRAWBAR	:-- FIXED HEIGHT FITTED 50 mm EYE X 600 mm HIGH
BRAKES	:-- 300 x 60 A.R. OVERRUN INERTIA
LIGHTS	:-- 12 VOLT-TYPE APPROVED SYSTEM WITH 13 PIN PLUG
CONSTRUCTION	:-- ALL STEEL WELDED
DRUM LIFT	:-- VIA HAND PUMP C/W LIFT BALANCE VALVE MECHANICAL LOCK WHEN DRUM RAISED FOR TRAVEL
PAINT	:-- FULL GLOSS BS 4800-08E51 YELLOW UNLESS OTHERWISE STATED

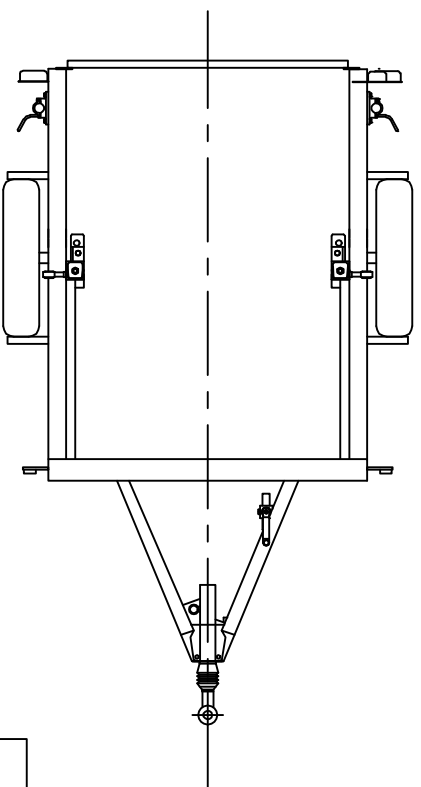
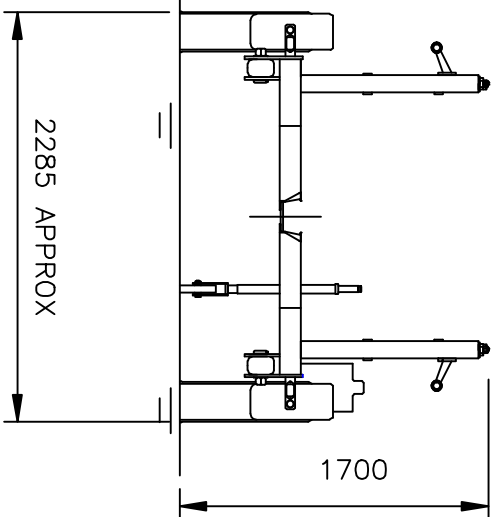
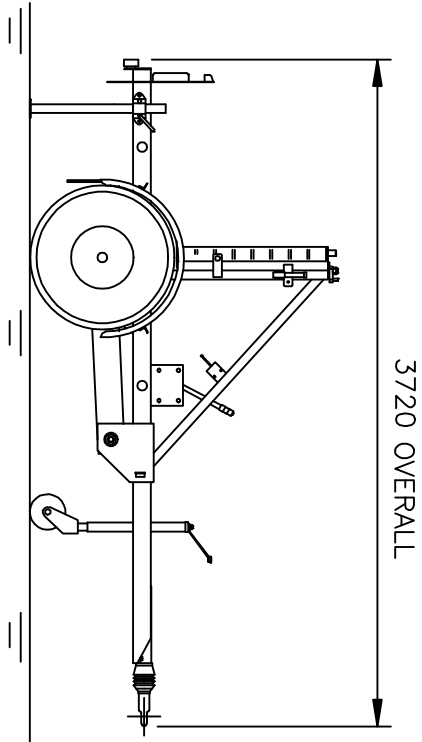

ALL DIMENSIONS / WEIGHTS  
QUOTED ARE APPROXIMATE  
ONLY AND MAY VARY DUE TO  
MANUFACTURERS TOLERANCES

TYPE APPROVAL No e11\*2007/46\*0733\*00

REV	AMENDMENT	DATE	NAME
 <p><b>S.E.B. INTERNATIONAL LTD.</b> UNITY ROAD, LOWMOOR ROAD INDUSTRIAL ESTATE, KIRKBY IN ASHFIELD, NOTTS.</p>			
TITLE CD60-ECWTA TYPE APPROVED			
NAME	RM	MAT'L	DRG No.
DATE	25/10/2012	SCALE	CD60 FIXED HT