



PIATTAFORME AEREE SEMOVENTI
SELF-PROPELLED WORK-PLATFORMS
PLATES-FORMES DE TRAVAIL AUTOMOTRICES
SELBSTFAHRENDE HUBARBEITSBÜHNEN
PLATAFORMAS ELEVADORAS AUTOPROPULSADAS
ZELFRIJDENDE HOOGWERKERS
SJÄLVGÅENDE ARBETSPLATTFORMAR
SAMOKRETNE RADNE PLATFORME

„X“ SERIES

**X8 EN - X10 EW - X10 EW WIND - X10 EN
X12 EW - X12 EW WIND - X12 EN - X14 EW**



**USE AND MAINTENANCE MANUAL
- ENGLISH - ORIGINAL INSTRUCTIONS**

AIRO is a division of **TIGIEFFE SRL**
Via Villasuperiore , 82 - 42045 Luzzara (RE) ITALY -
☎ +39-0522-977365 - 📠 +39-0522-977015

WEB: www.airo.com

Revision date	Description of revision
2010-01	<ul style="list-style-type: none"> • Update due to new machine directive 2006/42/EC • Model names updated
2010-11	<ul style="list-style-type: none"> • Biodegradable oil instructions introduced • Temperatures and oil list updated

Tigieffe thanks you for purchasing a product of its range, and invites you to read this manual. Here you can find all the necessary information for a correct use of the purchased machine. Therefore, you are advised to follow the instructions carefully and to read the manual thoroughly. The manual should be kept in a suitable place where no damage can occur to it. The content of this manual may be modified without prior notice and further obligations in order to add changes and improvements to the units already delivered. No reproduction or translation may take place without the written permission of the owner.

CONTENTS

1. INTRODUCTION	6
1.1 Legal aspects.....	6
1.1.1 Delivery of the machine.....	6
1.1.2 Declaration of commissioning, first check, further periodical checks and transfers of ownership	6
1.1.2.1 Declaration of commissioning and first check.....	6
1.1.2.2 Further periodical checks.....	7
1.1.2.3 Transfers of ownership	7
1.1.3 Operator training and information.....	7
1.2 Tests performed before delivery	7
1.3 Intended use	7
1.4 Description of the machine	8
1.5 Control panels.....	8
1.6 Drive power.....	8
1.7 Machine life, demolition and decommissioning.....	9
1.8 Identification.....	10
1.9 Location of main components	11
2. TECHNICAL FEATURES OF STANDARD MACHINES	12
2.1 X8EN Model.....	12
2.2 X10EW - X10EW-WIND Model.....	14
2.3 X10EN Model.....	16
2.4 X12EW - X12EW-WIND Model.....	18
2.5 X12EN Model.....	20
2.6 X14 EW Model.....	22
2.7 Vibrations and noise	24
3. SAFETY PRECAUTIONS	25
3.1 Personal protective equipment (PPE).....	25
3.2 General safety norms.....	25
3.3 Use instructions	26
3.3.1 General.....	26
3.3.2 Handling.....	26
3.3.3 Operating procedures.....	27
3.3.4 Wind speed according to BEAUFORT SCALE.....	28
3.3.5 Pressure of the machine on ground and load-bearing capacity of ground	29
3.3.6 High-voltage lines.....	30
3.4 Hazardous situations and/or accidents	30
4. INSTALLATION AND PRELIMINARY CHECKS	31
4.1 Becoming acquainted with the machine	31
4.2 Preliminary operation checks.....	31
5. USE INSTRUCTIONS	32
5.1 Platform control panel.....	32
5.1.1 Drive and steering	33
5.1.2 Drive with operator on the ground	34
5.1.3 Platform lifting and lowering	34
5.1.4 Manual extension of the platform	35
5.1.5 Other functions of the platform control panel.....	35
5.1.5.1 Manual horn.....	35
5.1.5.2 Emergency STOP button.....	35
5.1.5.3 Green warning light, control panel enabled	35
5.1.5.4 Red warning light, flat battery	35

5.1.5.5	Red warning light, overload.....	35
5.1.5.6	Red warning light, danger due to instability or drive control disable	35
5.2	Ground control panel.....	36
5.2.1	Hour meter / battery protection voltmeter (A)	36
5.2.2	Emergency stop button (B).....	36
5.2.3	On-off key / control panel selection (C)	37
5.2.4	Enabled control panel warning light (D).....	37
5.2.5	Platform lifting/lowering lever (E).....	37
5.2.6	Movement alarm.....	37
5.3	Platform access.....	38
5.4	Machine start-up	38
5.5	Machine stop.....	39
5.5.1	Normal stop	39
5.5.2	Emergency stop.....	39
5.6	Manual emergency lowering	40
5.7	Socket for electric tool connection (optional).....	41
5.8	End of work	41
6.	HANDLING AND CARRYING	42
6.1	Handling.....	42
6.2	Carrying	43
6.2.1	Removable guard rails.....	44
6.2.2	Fold-down guard rails (optional)	45
6.3	Emergency towing of the machine	47
7.	MAINTENANCE	48
7.1	Safety lock for maintenance operations	49
7.2	Machine cleaning	50
7.3	General maintenance.....	50
7.3.1	Various adjustments	51
7.3.2	Greasing.....	52
7.3.3	Hydraulic circuit oil level check and change	53
7.3.3.1	Biodegradable hydraulic oil (Optional)	54
7.3.3.2	Emptying	54
7.3.3.3	Filters	54
7.3.3.4	Washing.....	54
7.3.3.5	Filling	54
7.3.3.6	Commissioning / check.....	54
7.3.3.7	Mix	55
7.3.3.8	Micro-filtration	55
7.3.3.9	Disposal	55
7.3.3.10	Topping up.....	55
7.3.4	Pressure relief valve adjustment and operation check	57
7.3.5	Lifting circuit pressure relief valve operation check	58
7.3.6	Braking valves operation check.....	59
7.3.7	Inclinometer operation check.....	60
7.3.8	Platform overload controller operation check	61
7.3.9	Overload controller by-pass.....	62
7.3.10	Safety microswitches operation check.....	63
7.3.11	Dead-man switch operation check.....	64
7.4	Battery.....	65
7.4.1	General warning instructions	65
7.4.2	Battery maintenance.....	65
7.4.3	Battery recharge	66
7.4.4	Battery charger: fault report.....	67
7.4.5	Battery replacement	67
8.	MARKS AND CERTIFICATIONS.....	68
9.	PLATES AND STICKERS.....	69
10.	CHECK REGISTER.....	71

Annexes: Hydraulic and electric circuit diagrams
Check register
Declarations of conformity

1. INTRODUCTION

This Use and Maintenance Manual provides general instructions concerning the complete range of machines indicated on the cover. Therefore the description of their components, as well as control and safety systems, may include parts not present on your machine since supplied on request or not available. In order to keep pace with the technical development **AIRO-Tigieffe s.r.l.** reserves the right to modify the product and/or the use and maintenance manual at any time without updating the units already delivered.

1.1 Legal aspects

1.1.1 Delivery of the machine

Within EU (European Union) member countries the machine is delivered complete with:

- Use and Maintenance manual in your language
- CE mark applied on the machine
- Original EC Declaration of conformity
- Guarantee certificate

Only for Italy:

- Declaration of commissioning to ISPESL (National Institute for the prevention of accidents at the workplace)
- List of local ISPESL departments
- Declaration of internal testing

It is to be noted that the Use and Maintenance Manual is an integral part of the machine and a copy of this, together with copies of the documents certifying that the periodical checks have been carried out, must be kept on board in its suitable container. In the event of a transfer of ownership the machine must always be provided with its use and maintenance manual.

1.1.2 Declaration of commissioning, first check, further periodical checks and transfers of ownership

The legal obligations of the owner of the machine vary according to the country of commissioning. It is therefore recommended to inquire about the procedures in force in your country from the boards responsible for industrial safety. This manual contains a final section called "Check register" for a better filing of documents and recording of any modifications.

1.1.2.1 Declaration of commissioning and first check

In ITALY the owner of the Aerial Platform must notify the use of the machine to the local competent ISPESL and submit it to periodical compulsory checks. The first one of these checks is carried out by ISPESL, while the following ones by the territorial inspection boards (ASL/USL or ARPA). The checks are on a payment basis and the machine owner will be charged for them. For these checks, the territorial inspection boards (ASL/USL or ARPA) and ISPESL can be supported by authorized public or private subjects. The authorized private subjects acquire the qualification of responsables of the public service and refer directly to the public structure that controls this function.

To declare the commissioning of the machine in Italy, send the form that is supplied together with other documents upon machine delivery, by registered letter with advice of receipt.

ISPESL will assign a Serial Number and during the First Check will issue a "Check booklet" indicating only the detectable data of the machine already in use or inferable from the relative User Manual. Afterwards ISPESL will send a copy of the same booklet to the territorial inspection boards (ASL/USL or ARPA) which will carry out the further periodical mandatory checks (every year).

1.1.2.2 Further periodical checks

Yearly checks are compulsory. In Italy the owner of the Aerial Platform must apply for a periodical check by sending a registered letter to the local competent inspection board (ASL/USL or ARPA) at least twenty days before the expiry of the year from the last check.

NB: If a machine without a valid control document should be moved in an area outside the competence of the usual inspection board, the owner of the machine must ask the inspection board, competent for the new territory where the machine is to be used, for the yearly check.

1.1.2.3 Transfers of ownership

In case of transfer of ownership (in Italy) the new owner of the Aerial Platform must notify the ownership of the machine to the local competent inspection board (ASL/USL or ARPA) by enclosing a copy of:

- Declaration of conformity issued by the manufacturer
- Declaration of commissioning carried out by the first owner

1.1.3 Operator training and information

The employer must ensure that the workers appointed to use the equipment are adequately and specifically trained so they are able to use the Mobile Elevating Work Platform in a proper and safe way and also avoid the risks caused by other people.

1.2 Tests performed before delivery

Before being placed on the market, each MEWP undergoes the following tests:

- Braking test
- Overload test
- Operating test

1.3 Intended use

The machine described in this use and maintenance manual is a self-propelled aerial platform intended for lifting persons and materials (equipment and work materials) in order to carry out maintenance, installation, cleaning, painting, de-painting, sand-blasting, welding operations, etc.

The max. capacity allowed (which varies according to the model – see paragraph “Technical features”) is divided as follows:

- 80 Kg for each person on board
- 40 Kg for equipment
- any remaining load is represented by the work materials.

In any case NEVER exceed the maximum capacity allowed as indicated in paragraph "Technical features". Persons, tools and work materials can be loaded on the platform only from the access position (platform lowered). It is absolutely forbidden to load persons, tools and work materials on the platform when it is not in access position.

All loads must be positioned inside the platform. Do not lift loads (even if complying with the maximum capacity allowed) hanging from the platform or lifting structure.

Do not carry large-sized panels since they increase the resistance to wind force thus causing the machine to overturn.

While the machine is being displaced with lifted platform, no horizontal loads can be loaded onto the platform (operators on board are not allowed to pull wires or ropes, etc.).

An overload controller stops the operation of the machine if the load on the platform exceeds by 20% approx. the nominal load (see chapter "General use rules") and platform is lifted.

The machine cannot be used in areas where road vehicles operate. Always surround the working area by means of suitable signs when the machine is used in public areas.

Do not use the machine to tow trucks or other vehicles.

All types of machine use other than those for which it was designed must be approved in writing by the machine manufacturer following a specific request on the part of the user.



Do not use the machine for purposes other than those for which it was designed, except after making a request and having obtained written permission in this sense from the manufacturer.

1.4 Description of the machine

The machine described in this use and maintenance manual is a Mobile Elevating Work Platform equipped with:

- Motorized chassis equipped with wheels
- Vertical scissor lifting structure operated by one or more hydraulic cylinders (the number of cylinders varies according to machine model)
- Operator platform with manual slide-out extension deck (the max. capacity varies according to the model - see chapter "Technical features")

The chassis is motorised to allow the machine to move (see "Use instructions") and has two rear idle wheels and two front driving and steering wheels. The rear wheels are equipped with hydraulic parking brakes, positive logic type (when drive controls are released brakes are automatically activated).

The hydraulic cylinders which move the articulated structure are provided with electric safety valves directly flanged on the same. These devices allow the arms to remain in position even if one of the supply tubes accidentally breaks.

The platform, which can be manually extended from the front side, is equipped with guard rails and toe-boards of a prescribed height (the height of the guard rails is 1100 mm; the height of the toe-boards is 150 mm, the entrance area has a toe-board of at least 100 mm).

When no motive power is available, the manual emergency lowering can be controlled enabling the knob manually from the ground (see instructions plates).

The allowed capacity on the platform does not change depending on the position of the extension deck.

1.5 Control panels

The machine is equipped with two control panels:

- on the platform for normal use of the machine
- on the chassis you can find: the emergency controls to lower or stop the platform and the emergency stop button, a key-selector to select the control panel and to start the machine.

1.6 Drive power

The machines are powered by an electro-hydraulic system consisting of rechargeable accumulators and electric pump.

Both the hydraulic and the electric systems are equipped with all necessary protections (see electric and hydraulic circuit diagrams annexed to this manual).

1.7 Machine life, demolition and decommissioning

The machine has been designed to last for 10 years in normal operating environments, if properly used and serviced. Within this period, the manufacturer must carry out a complete inspection/overhaul.

If disposal of the machine is necessary, comply with current local regulations.

In Italy, the demolition/decommissioning must be notified to the local ASL / USL or ARPA.

The machine consists mainly of metal parts which are easy to be identified (steel for the most parts, and aluminium for the hydraulic blocks); thus, we can state that the machine can be recycled at 90%.



**European standards and those transposed by the member countries relating to respect for the environment and the disposal of wastes envisage heavy administrative and penal fines in case of infringement.
In case of demolition/decommissioning, carefully keep to the provisions of applicable regulations, especially as regards materials such as hydraulic oil and batteries.**

1.8 Identification

In order to identify the machine, when spare parts and service are required, always mention the information given in the serial number plate. Should this plate (as well as the various stickers applied on the machine) be lost or illegible, it is to be replaced as soon as possible. In order to identify the machine when no plate is available the serial number is also stamped on the chassis. To locate the plate and the stamp of the serial number, see the following picture. It is recommended to copy such data in the following boxes.

MODEL: _____	CHASSIS: _____	YEAR: _____
--------------	----------------	-------------

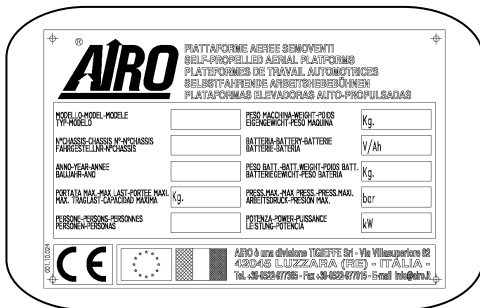

SF xx.xx.xx

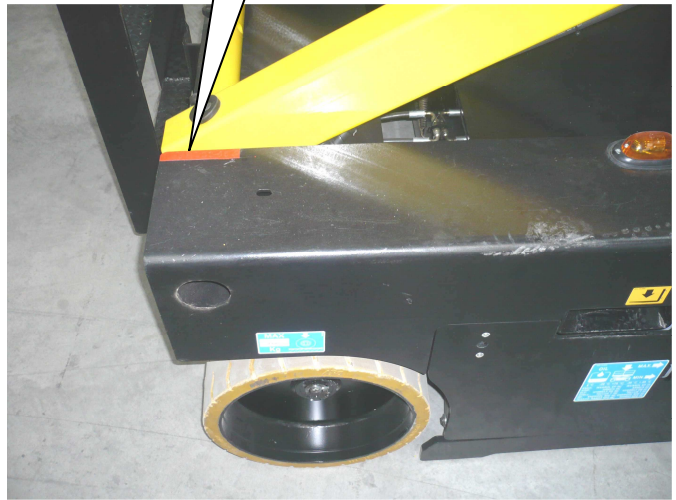
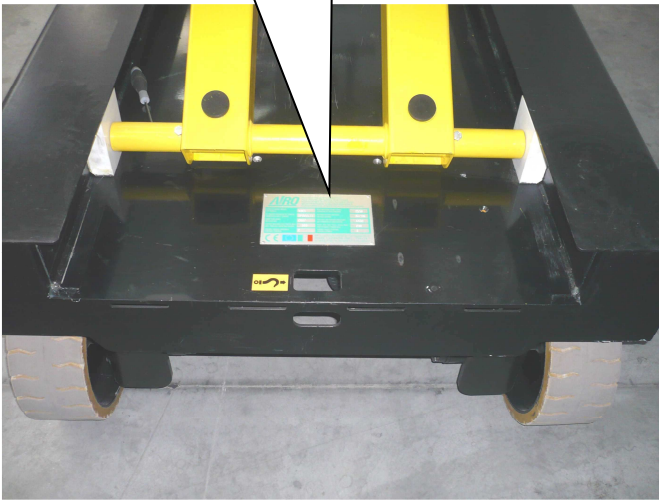

1.9 Location of main components

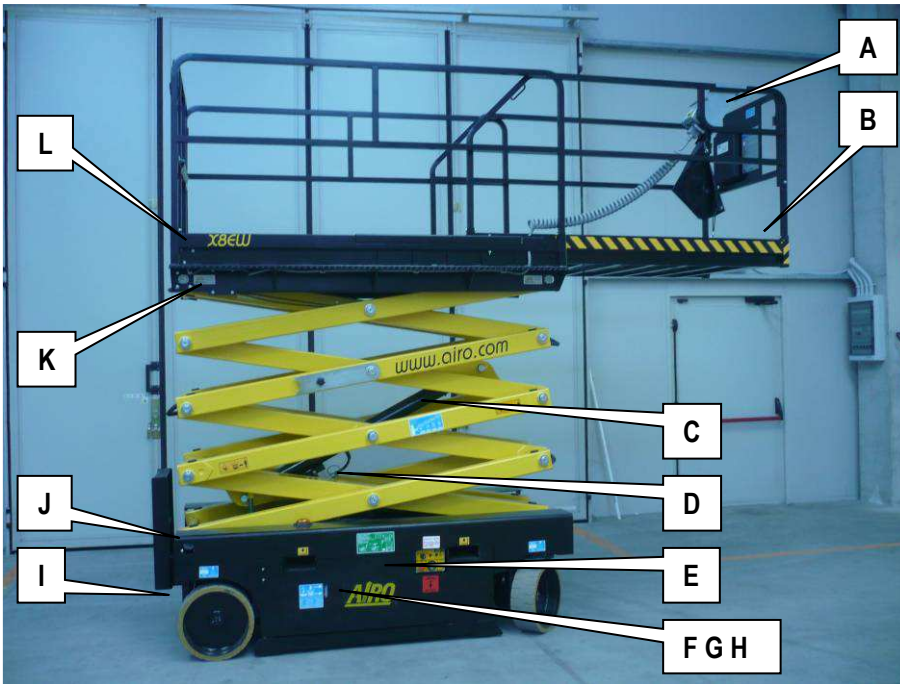

1-1: Right view

- A. Platform control panel
- B. Bubble level (optional) for visual check of platform levelling
- C. Lifting cylinder
- D. Lowering control valve
- E. Ground control panel
- F. Electric control unit and inclinometer
- G. Tank
- H. Electric pump
- I. Manual device for emergency lowering
- J. Platform height control M1 microswitch
- K. Electronic board of platform overload controller
- L. 230V socket (optional)
- M. Overload controller sensors
- N. Batteries
- O. Battery charger
- P. Parking brakes
- Q. MPT1 and MPT2 microswitches to control the position of the pot-hole guards
- R. Hydraulic traction motors
- S. Steering cylinder
- T. Bipolar power connector
- U. Pot-hole guards

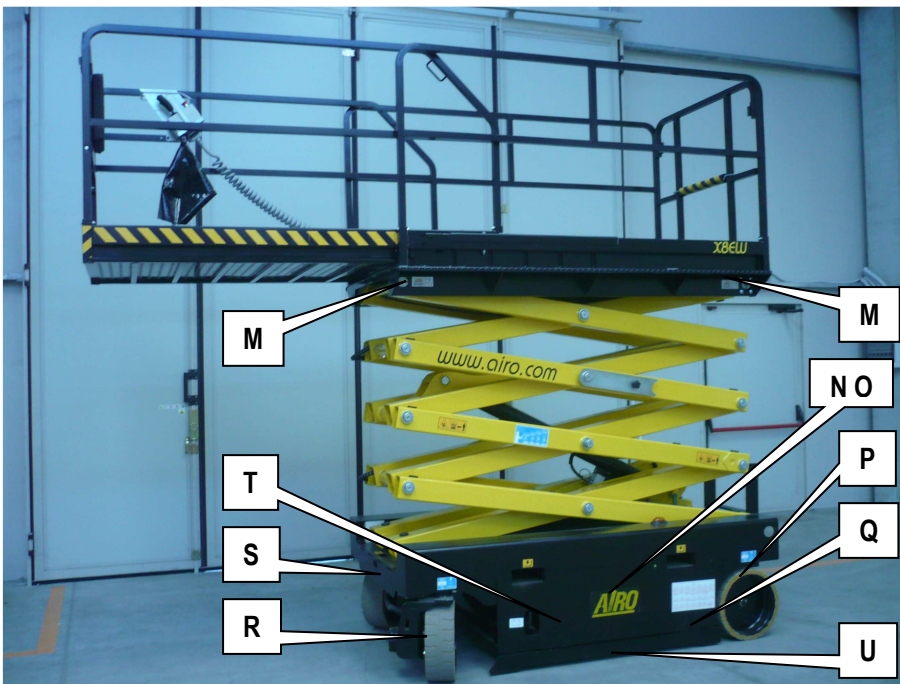

1-2: Left view

2. TECHNICAL FEATURES OF STANDARD MACHINES



THE TECHNICAL FEATURES OF THE PRODUCTS IN THE FOLLOWING PAGES CAN BE MODIFIED WITHOUT PRIOR NOTICE

2.1 X8EN

Model

	X8EN	
Maximum working height	8.3	m
Maximum platform height	6.3	m
Ground clearance (pot-hole guards lifted)	100	mm
Ground clearance (pot-hole guards lowered)	15	mm
Platform height for safety speed activation	1.8	m
Internal steering radius	0	m
External steering radius	2.28	m
Maximum capacity (m)	400	kg
Max. number of people on the platform (n) – indoors	3	
Tool and material weight (me) ** – indoors	160	kg
Max. number of people on the platform (n) – outdoors	-	
Tool and material weight (me) ** – outdoors	-	
Maximum deck extension	1.5	m
Maximum capacity on deck extension	400	kg
Maximum amount of people on deck extension	3	
Maximum drive height	Max	
Maximum platform dimensions (extended)	0.89 x 3.75	m
Max. hydraulic pressure	230	bar
Max. pressure of lifting circuit	160	bar
Min. pressure of braking circuit	60÷70	bar
Tyre dimensions	Ø410 x 150	mm
Type of tyres	Cushion soft	
Transport dimensions with removable guard rails installed *	0.89x2.4x2.23	m
Transport dimensions with removable guard rails not installed *	0.89x2.4x1.28	m
Transport dimensions with guard rails folded down (optional) *	0.89x2.4x1.73	m
Machine weight (unloaded)	2000	kg
Stability limit:		
Longitudinal inclination	3	°
Transversal inclination	2	°
Maximum wind speed	0	m/s
Max. load per wheel	1200	Kg
Performance:		
Battery capacity and voltage	4 x 6 / 200	V/Ah
Battery weight	4 x 32	kg
Single-phase battery charger	24 / 25	V/A
Max. current absorbed by the battery charger	12	A
Electric pump power	3	kW
Max. absorbed current	160	A
Max. drive speed	3	km/h
Safety drive speed	0.6	km/h
Lowering/lifting time (unloaded)	47 / 47	Sec.
Oil tank capacity	30	Lt.
Gradeability	26	%
Max. operating temperature	+50	C
Min. operating temperature	-15	C

(*) removing the ladder, the machine overall dimensions are further reduced (length = 2.25 m)

(**) me = m – (n x 80)



X8 EN

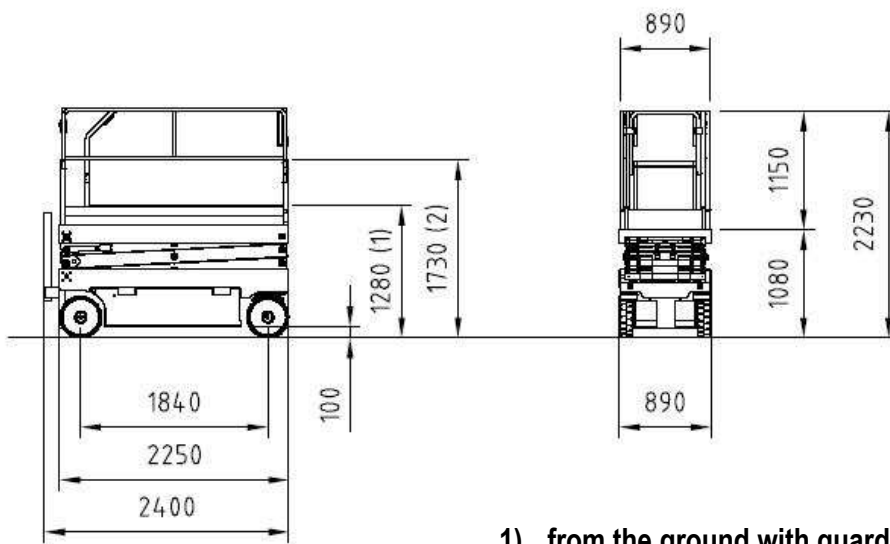
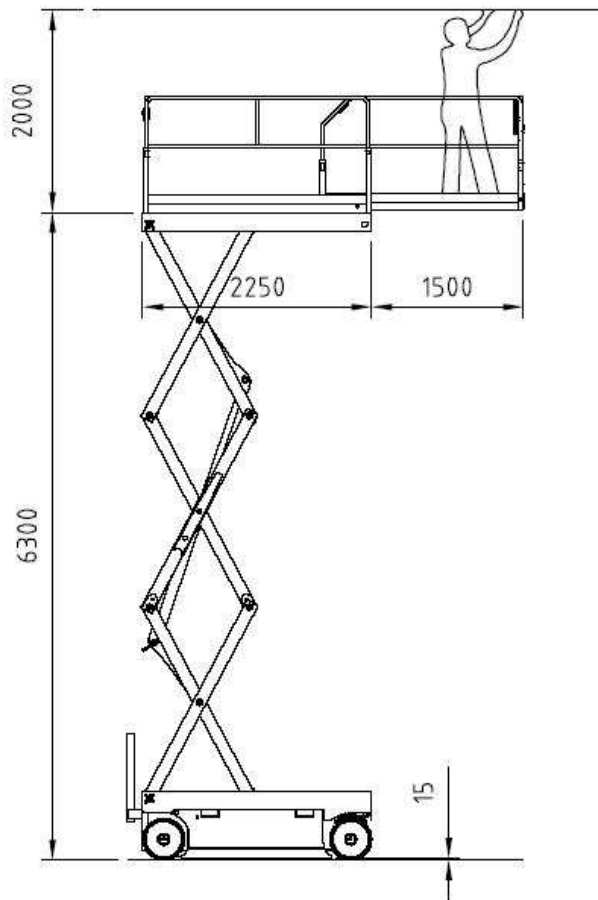

- 1) from the ground with guard rails removed
- 2) from the ground with guard rails folded down

2.2 X10EW - X10EW-WIND Model

Dimensions:		X10EW-WIND	X10EW	
	Maximum working height	10.2	10.2	m
	Maximum platform height	8.2	8.2	m
	Ground clearance (pot-hole guards lifted)	100	100	mm
	Ground clearance (pot-hole guards lowered)	15	15	mm
	Platform height for safety speed activation	2.1	2.1	m
	Internal steering radius	0	0	m
	External steering radius	2.43	2.43	m
	Maximum capacity (m)	500	500	kg
	Max. number of people on the platform (n) – indoors	3	3	
	Tool and material weight (me) ** – indoors	260	260	kg
	Max. number of people on the platform (n) – outdoors	1	-	
	Tool and material weight (me) ** – outdoors	420	-	kg
	Maximum deck extension	1.5	1.5	m
	Maximum capacity on deck extension	500	500	kg
	Max. number of people on deck extension – indoors	3	3	
	Max. number of people on deck extension – outdoors	1	-	
	Maximum drive height	Max.	Max.	
	Maximum platform dimensions (extended)	1.2 x 3.75	1.2 x 3.75	m
	Max. hydraulic pressure	230	230	bar
	Max. pressure of lifting circuit	240	240	bar
	Min. pressure of braking circuit	60÷70	60÷70	bar
	Tyre dimensions	Ø410 x 150	Ø410 x 150	mm
	Type of tyres	Cushion soft	Cushion soft	
	Transport dimensions with removable guard rails installed *	1.2x2.4x2.36	1.2x2.4x2.36	m
	Transport dimensions with removable guard rails not installed *	1.2x2.4x1.42	1.2x2.4x1.42	m
	Transport dimensions with guard rails folded down (optional) *	1.2x2.4x1.86	1.2x2.4x1.86	m
	Machine weight (unloaded)	2850	2350	kg
Stability limit:				
	Longitudinal inclination	3	3	°
	Transversal inclination	2	2	°
	Maximum wind speed	12.5	0	m/s
	Max. load per wheel	1680	1380	Kg
Performance:				
	Battery capacity and voltage	4x6 / 200	4x6 / 200	V/Ah
	Battery weight	4x32	4x32	kg
	Single-phase battery charger	24/25	24 / 25	V/A
	Max. current absorbed by the battery charger	12	12	A
	Electric pump power	3	3	kW
	Max. absorbed current	160	160	A
	Max. drive speed	3	3	km/h
	Safety drive speed	0.6	0.6	km/h
	Lowering/lifting time (unloaded)	47 / 47	47 / 47	Sec.
	Oil tank capacity	30	30	Lt.
	Gradeability	18	25	%
	Max. operating temperature	+50	+50	C
	Min. operating temperature	-15	-15	C

(*) removing the ladder, the machine overall dimensions are further reduced (length = 2.25 m)

(**) me = m – (n x 80)

[®] **AIRO**

X10 EW

X10 EW WIND

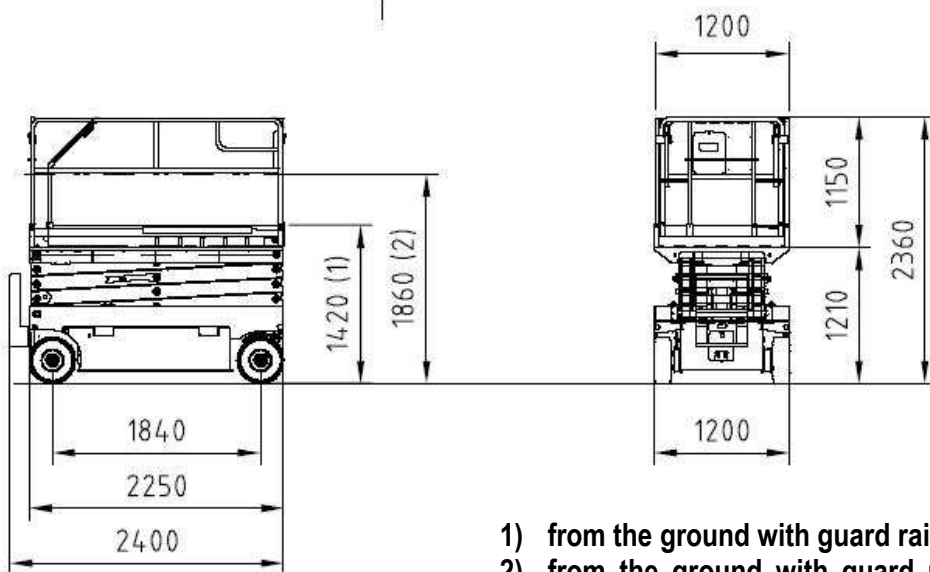
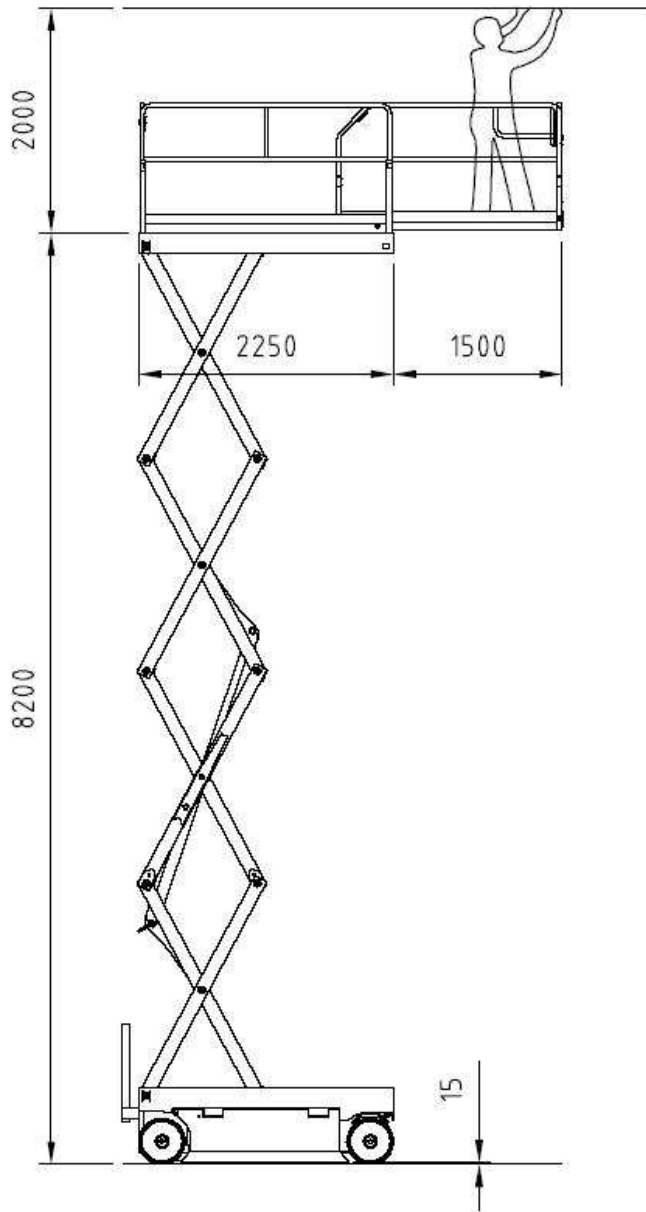

- 1) from the ground with guard rails removed
- 2) from the ground with guard rails folded

2.3 X10EN Model

Dimensions:		X10EN	
	Maximum working height	10.2	m
	Maximum platform height	8.2	m
	Ground clearance (pot-hole guards lifted)	100	mm
	Ground clearance (pot-hole guards lowered)	15	mm
	Platform height for safety speed activation	2.1	m
	Internal steering radius	0	m
	External steering radius	2.28	m
	Maximum capacity (m)	400	kg
	Max. number of people on the platform (n) – indoors	3	
	Tool and material weight (me) ** – indoors	160	kg
	Max. number of people on the platform (n) – outdoors	-	
	Tool and material weight (me) ** – outdoors	-	
	Maximum deck extension	1.5	m
	Maximum capacity on deck extension	400	kg
	Max. number of people on deck extension – indoors	3	
	Max. number of people on deck extension – outdoors	-	
	Maximum drive height	Max.	
	Maximum platform dimensions (extended)	0.89 x 3.75	m
	Max. hydraulic pressure	230	bar
	Max. pressure of lifting circuit	210	bar
	Min. pressure of braking circuit	60÷70	bar
	Tyre dimensions	Ø410 x 150	mm
	Type of tyres	Cushion soft	
	Transport dimensions with removable guard rails installed *	0.89x2.4x2.42	m
	Transport dimensions with removable guard rails not installed *	0.89x2.4x1.48	m
	Transport dimensions with guard rails folded down (optional) *	0.89x2.4x2.42	m
	Machine weight (unloaded)	2750	kg
Stability limit:			
	Longitudinal inclination	3	°
	Transversal inclination	2	°
	Maximum wind speed	0	m/s
	Max. load per wheel	1650	Kg
Performance:			
	Battery capacity and voltage	4 x 6 / 200	V/Ah
	Battery weight	4 x 32	kg
	Single-phase battery charger	24 / 25	V/A
	Max. current absorbed by the battery charger	12	A
	Electric pump power	3	kW
	Max. absorbed current	160	A
	Max. drive speed	3	km/h
	Safety drive speed	0.6	km/h
	Lowering/lifting time (unloaded)	47 / 47	Sec.
	Oil tank capacity	30	Lt.
	Gradeability	20	%
	Max. operating temperature	+50	C
	Min. operating temperature	-15	C

(*) removing the ladder, the machine overall dimensions are further reduced (length = 2.25 m)

(**) me = m – (n x 80)

[®] AIRO

X10 EN

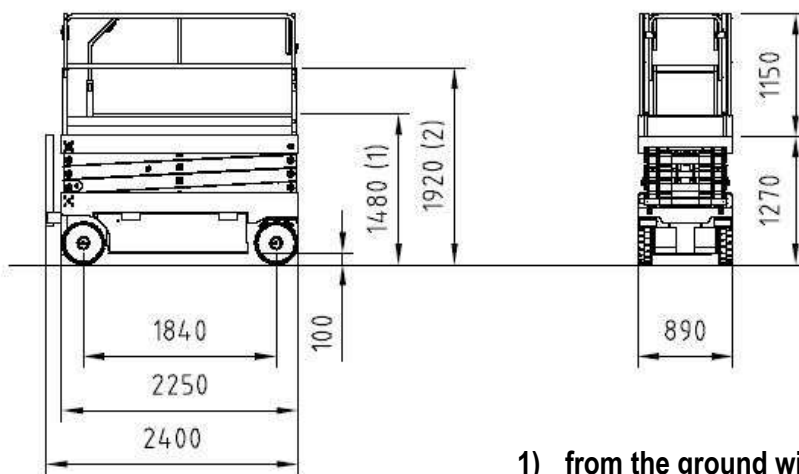
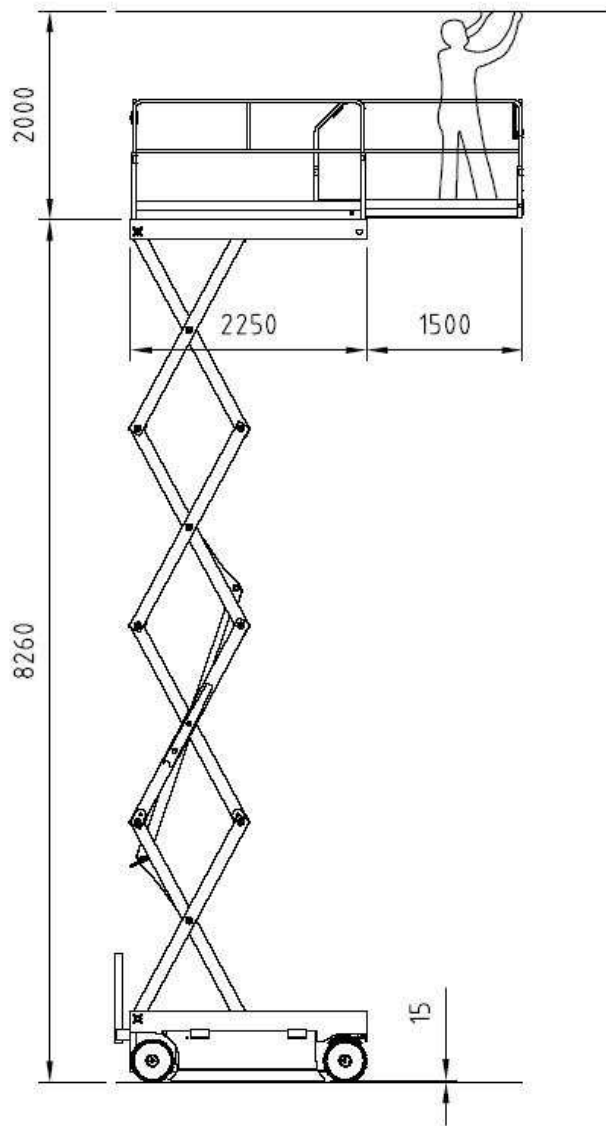

- 1) from the ground with guard rails removed
- 2) from the ground with guard rails folded

2.4 X12EW - X12EW-WIND Model

Dimensions:		X12EW-WIND	X12EW	
	Maximum working height	12.1	12.1	m
	Maximum platform height	10.1	10.1	m
	Ground clearance (pot-hole guards lifted)	100	100	mm
	Ground clearance (pot-hole guards lowered)	15	15	mm
	Platform height for safety speed activation	2.5	2.5	m
	Internal steering radius	0	0	m
	External steering radius	2.43	2.43	m
	Maximum capacity (m)	300	450	kg
	Max. number of people on the platform (n) – indoors	3	3	
	Tool and material weight (me) ** – indoors	60	210	kg
	Max. number of people on the platform (n) – outdoors	1	-	
	Tool and material weight (me) ** – outdoors	220	-	kg
	Maximum deck extension	1.5	1.5	m
	Maximum capacity on deck extension	300	450	kg
	Max. number of people on deck extension – indoors	3	3	
	Max. number of people on deck extension – outdoors	1	-	
	Maximum drive height	Max.	Max.	
	Maximum platform dimensions (extended)	1.2 x 3.75	1.2 x 3.75	m
	Max. hydraulic pressure	230	230	bar
	Max. pressure of lifting circuit	160	170	bar
	Min. pressure of braking circuit	60÷70	60÷70	bar
	Tyre dimensions	Ø410 x 150	Ø410 x 150	mm
	Type of tyres	Cushion soft	Cushion soft	
	Transport dimensions with removable guard rails installed *	1.2x2.4x2.48	1.2x2.4x2.48	m
	Transport dimensions with removable guard rails not installed *	1.2x2.4x1.54	1.2x2.4x1.54	m
	Transport dimensions with guard rails folded down (optional) *	1.2x2.4x1.98	1.2x2.4x1.98	m
	Machine weight (unloaded)	3320	2820	kg
Stability limit:				
	Longitudinal inclination	3	3	°
	Transversal inclination	1.5	2	°
	Maximum wind speed	12.5	0	m/s
	Max. load per wheel	1950	1710	Kg
Performance:				
	Battery capacity and voltage	4x6 / 280	4x6 / 280	V/Ah
	Battery weight	4x47	4x47	kg
	Single-phase battery charger	24 / 25	24 / 25	V/A
	Max. current absorbed by the battery charger	12	12	A
	Electric pump power	4	4	kW
	Max. absorbed current	200	200	A
	Max. drive speed	3	3	km/h
	Safety drive speed	0.6	0.6	km/h
	Lowering/lifting time (unloaded)	70 / 70	70 / 70	Sec.
	Oil tank capacity	30	30	Lt.
	Gradeability	23	26	%
	Max. operating temperature	+50	+50	C
	Min. operating temperature	-15	-15	C

(*) removing the ladder, the machine overall dimensions are further reduced (length = 2.25 m)

(**) me = m – (n x 80)



X12 EW

X12 EW WIND

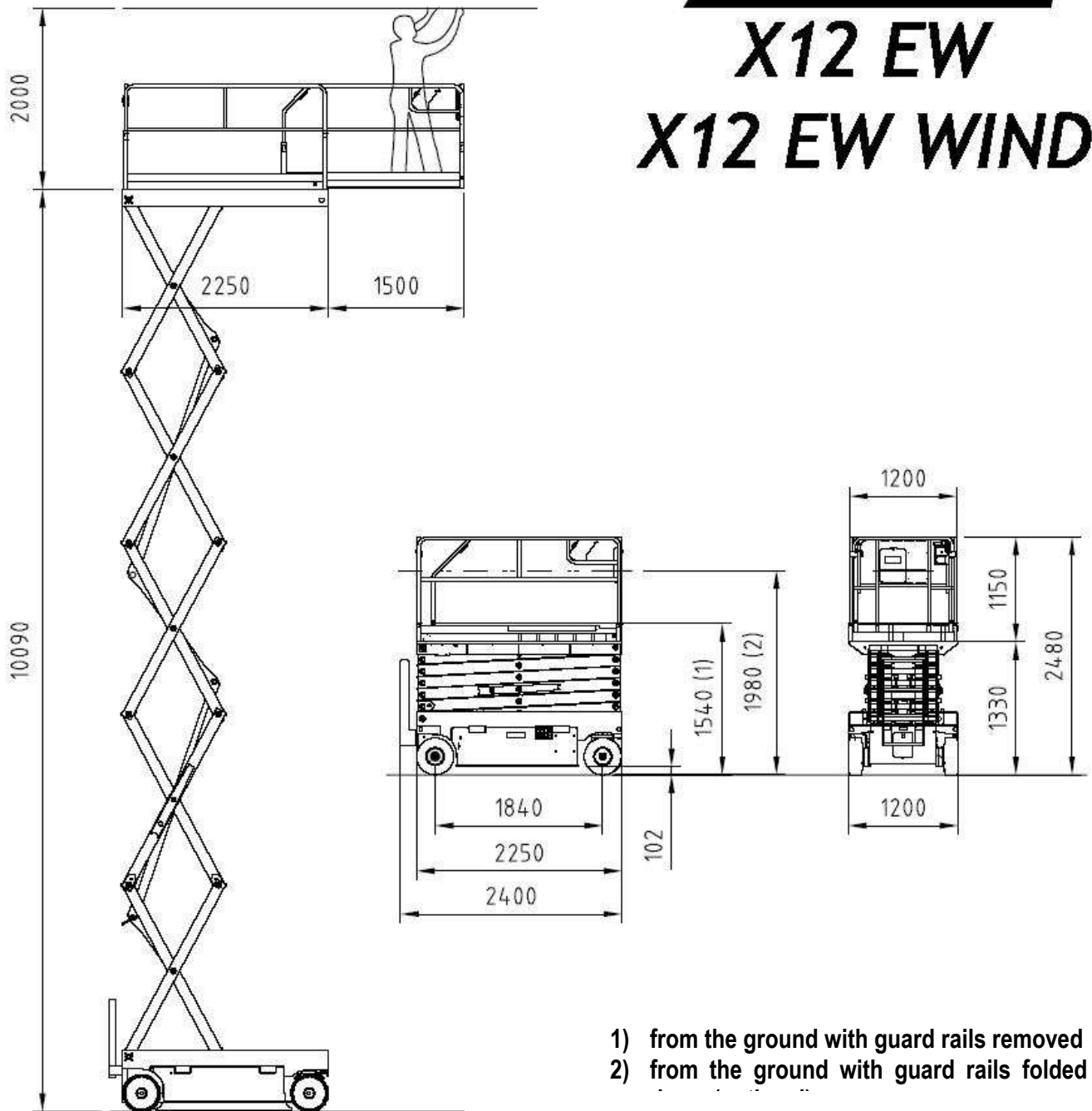

2.5 X12EN Model

Dimensions:		X12EN	
	Maximum working height	12.1	m
	Maximum platform height	10.1	m
	Ground clearance (pot-hole guards lifted)	100	mm
	Ground clearance (pot-hole guards lowered)	15	mm
	Platform height for safety speed activation	2.5	m
	Internal steering radius	0	m
	External steering radius	2.28	m
	Maximum capacity (m)	300	kg
	Max. number of people on the platform (n) – indoors	3	
	Tool and material weight (me) ** – indoors	60	kg
	Max. number of people on the platform (n) – outdoors	-	
	Tool and material weight (me) ** – outdoors	-	
	Maximum deck extension	1.5	m
	Maximum capacity on deck extension	300	kg
	Max. number of people on deck extension – indoors	3	
	Max. number of people on deck extension – outdoors	-	
	Maximum drive height	Max.	m
	Maximum platform dimensions (extended)	0.89 x 3.75	m
	Max. hydraulic pressure	230	bar
	Max. pressure of lifting circuit	160	bar
	Min. pressure of braking circuit	60÷70	bar
	Tyre dimensions	Ø410 x 150	mm
	Type of tyres	Cushion soft	
	Transport dimensions with removable guard rails installed *	0.89x2.4x2.54	m
	Transport dimensions with removable guard rails not installed *	0.89x2.4x1.6	m
	Transport dimensions with guard rails folded down (optional) *	0.89x2.4x2.04	m
	Machine weight (unloaded)	3430	kg
Stability limit:			
	Longitudinal inclination	3	°
	Transversal inclination	1.2	°
	Maximum wind speed	0	m/s
	Max. load per wheel	2020	Kg
Performance:			
	Battery capacity and voltage	4x6 / 280	V/Ah
	Battery weight	4x47	kg
	Single-phase battery charger	24 / 25	V/A
	Max. current absorbed by the battery charger	12	A
	Electric pump power	4	kW
	Max. absorbed current	200	A
	Max. drive speed	3	km/h
	Safety drive speed	0.6	km/h
	Lowering/lifting time (unloaded)	70 / 70	Sec.
	Oil tank capacity	30	Lt.
	Gradeability	23	%
	Max. operating temperature	+50	C
	Min. operating temperature	-15	C

(*) removing the ladder, the machine overall dimensions are further reduced (length = 2.25 m)

(**) me = m – (n x 80)

[®] AIRO

X12 EN

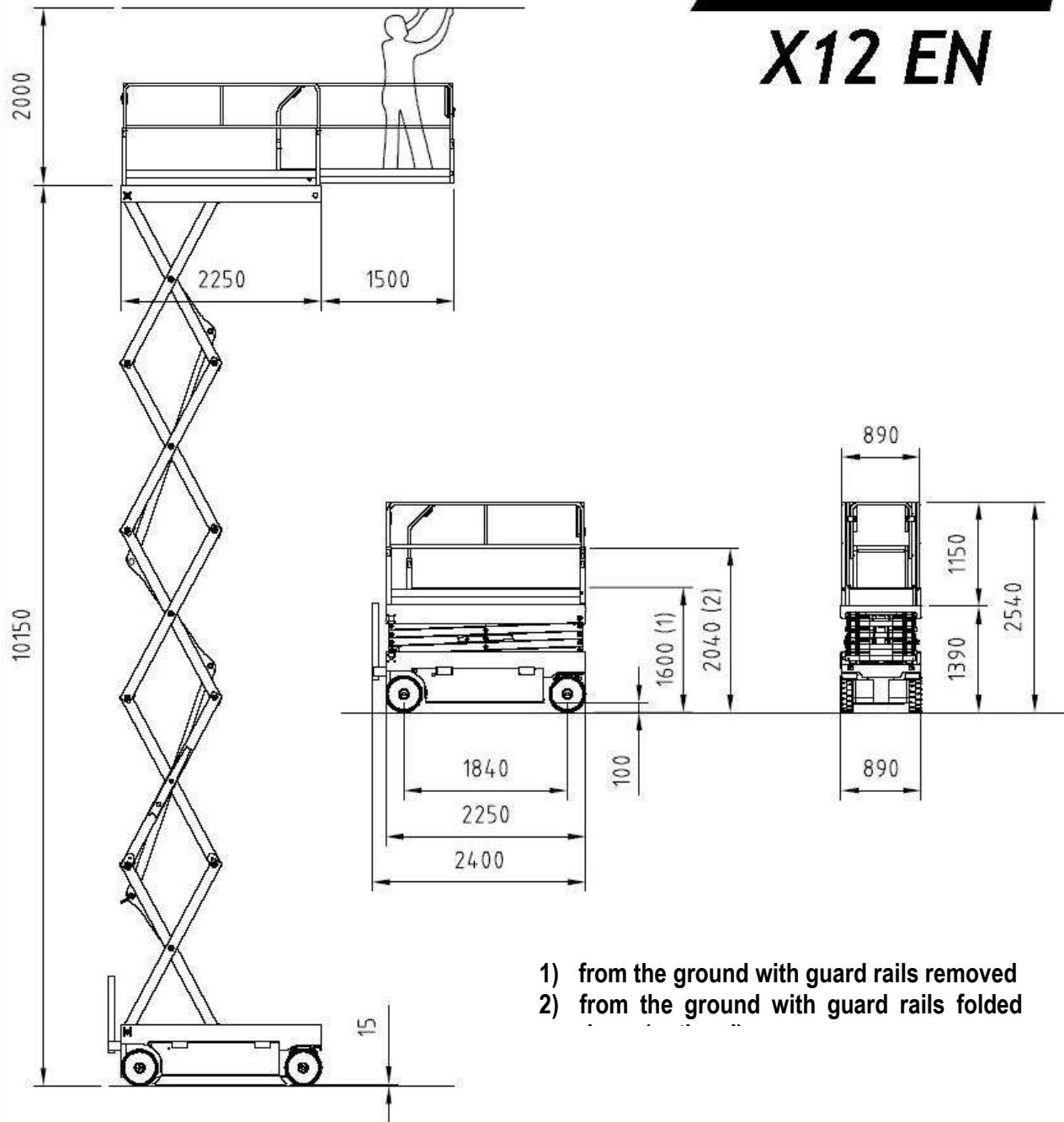

2.6 X14 EW Model

Dimensions:		X14EW	
	Maximum working height	14	m
	Maximum platform height	12	m
	Ground clearance (pot-hole guards lifted)	100	mm
	Ground clearance (pot-hole guards lowered)	15	mm
	Platform height for safety speed activation	2.8	m
	Internal steering radius	0	m
	External steering radius	2.43	m
	Maximum capacity (m)	400	kg
	Max. number of people on the platform (n) – indoors	3	
	Tool and material weight (me)** – indoors	160	kg
	Max. number of people on the platform (n) – outdoors	-	
	Tool and material weight (me)** – outdoors	-	
	Maximum deck extension	1.5	m
	Maximum capacity on deck extension	400	kg
	Max. number of people on deck extension – indoors	3	
	Max. number of people on deck extension – outdoors	-	
	Maximum drive height	Max.	m
	Maximum platform dimensions (extended)	1.2 x 3.75	m
	Max. hydraulic pressure	230	bar
	Max. pressure of lifting circuit	200	bar
	Min. pressure of braking circuit	60÷70	bar
	Tyre dimensions	Ø410 x 150	mm
	Type of tyres	Cushion soft	
	Transport dimensions with removable guard rails installed *	1.2x2.4x2.62	m
	Transport dimensions with removable guard rails not installed *	1.2x2.4x1.67	m
	Transport dimensions with guard rails folded down (optional) *	1.2x2.4x2.13	m
	Machine weight (unloaded)	3365	kg
Stability limit:			
	Longitudinal inclination	3	°
	Transversal inclination	1.5	°
	Maximum wind speed	0	m/s
	Max. load per wheel	1980	Kg
Performance:			
	Battery capacity and voltage	4x6 / 280	V/Ah
	Battery weight	4x47	kg
	Single-phase battery charger	24 / 25	V/A
	Max. current absorbed by the battery charger	12	A
	Electric pump power	4	kW
	Max. absorbed current	200	A
	Max. drive speed	3	km/h
	Safety drive speed	0.6	km/h
	Lowering/lifting time (unloaded)	70 / 70	Sec.
	Oil tank capacity	30	Lt.
	Gradeability	23	%
	Max. operating temperature	+50	C
	Min. operating temperature	-15	C

(*) removing the ladder, the machine overall dimensions are further reduced (length = 2.25 m)

(**) me = m – (n x 80)

[®] AIRO

X14 EW

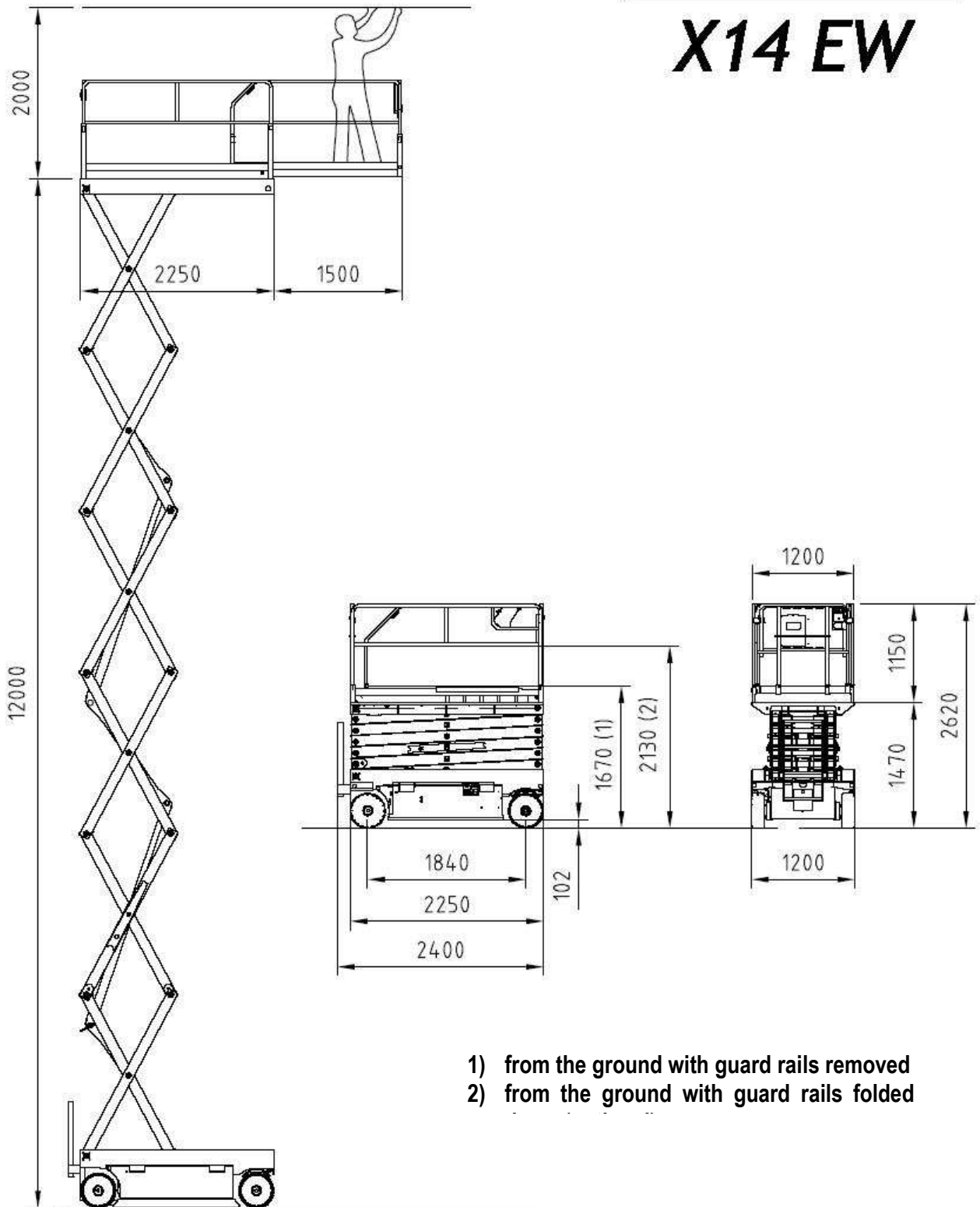

- 1) from the ground with guard rails removed
- 2) from the ground with guard rails folded

2.7 Vibrations and noise

Noise tests have been carried out under the most unfavourable conditions to study the effects on the operator. The level of acoustic pressure weighed (**A**) at work places does not exceed **70dB (A)** for each model to which this Use and Maintenance manual refers.

As to vibrations in ordinary working conditions:

- The average weighted quadratic value in frequency of the acceleration which the upper members have to withstand is below **2.5 m/sec²** for each of the models to which this Use and Maintenance manual refers.
- The average weighted quadratic value in frequency of the acceleration which the body has to withstand is below **0.5 m/sec²** for each of the models to which this Use and Maintenance manual refers.

3. SAFETY PRECAUTIONS

3.1 Personal protective equipment (PPE)

Always wear personal protective equipment according to current regulations concerning industrial health and safety (in particular, hard hat and safety shoes are **COMPULSORY**).

It is the operator or safety manager's responsibility to choose the personal protective equipment (PPE) depending on the activity to be carried out. For their correct use and maintenance, refer to the equipment manuals themselves.

The use of safety harness is not compulsory except in certain countries with specific regulations.

In Italy, the consolidation act on safety, **Law Decree 81/08**, has made the use of a safety harness mandatory.

3.2 General safety norms



- Only adults (18 years old), after carefully reading this manual, are allowed to use the machine. The employer is responsible for training.
- The platform is intended for people carriage; therefore, comply with the current local regulations relevant to this class of machines (see chapter 1).
- At least two users must operate the machine, one of them on the ground, able to carry out the emergency operations described in this handbook.
- Always keep the machine at a safety distance from power lines as indicated in the next chapters.
- Use the machine according to the capacity values indicated in the technical features section. The identification plate shows the maximum number of people allowed on the platform at any one time, the maximum capacity and the tool and material weight : **Never exceed the indicated figures.**
- Do NOT use the framework of the platform or any of its elements for grounding connection while welding on platform.
- It is absolutely forbidden to load and/or unload persons and/or material with platform not in the access position.
- It is the machine owner and/or safety manager's responsibility to check that the maintenance and repair operations are carried out by skilled personnel.

3.3 Use instructions

3.3.1 General

- The electric and hydraulic circuits are provided with safety devices, calibrated and sealed by the manufacturer:



DO NOT TAMPER WITH AND MODIFY THE CALIBRATION OF ANY COMPONENT OF THE ELECTRIC AND HYDRAULIC SYSTEMS.

- The machine must be used only in areas well lit up, checking that the ground is flat and firm. The machine may not be used if the lighting conditions are not sufficient. The machine is not equipped with any lightning system.
- Before using the machine check its integrity and conservation state.
- During maintenance operations do not dispose of any waste materials in the environment, but comply with current regulations.
- Do not carry out any service or maintenance operations when the machine is connected to the mains supply. Follow the instructions given in the following paragraphs.
- Do not approach the electric and hydraulic system components with sources of heat or flames.
- Do not increase the max. allowed height by means of scaffolds, ladders or other.
- With the machine lifted, do not fasten the platform to any structure (beams, pillars or wall).
- Do not use the machine as a crane, hoist or lift.
- Protect the machine (in particular the platform control panel by means of the specially provided cover- optional) and the operator when working in adverse environmental conditions (painting, de-painting, sand-blasting, washing, etc.).
- Using the machine in bad weather conditions is forbidden; in particular, wind speeds must not exceed the limits indicated in the technical Specifications (to measure speeds, see following chapters).
- Machines with a wind speed limit of 0 m/s are to be used indoors only.
- In the event of rain or in parking condition always protect the platform control panel by means of the specially provided cap (optional).
- Do not use the machine in areas where risks of fire or explosion exist.
- Do not use pressurized water jets (high-pressure cleaners) to wash the machine.
- Overloading the work platform is forbidden.
- Avoid collisions and/or contacts with other vehicles and fixed structures.
- Leaving or accessing the work platform is forbidden unless this is in the position required for access or leaving (see the "Accessing the platform" chapter).



3.3.2 Handling

- Before any movement make sure that the machine plugs are disconnected from the power source.
- In order to avoid any instability, use the machine on regular and firm grounds. To prevent the machine from overturning, comply with the max. gradeability values indicated in the Technical features section under paragraph "**Stability limits**". However, movements on inclined grounds are to be carried out with the utmost caution.
- As soon as the platform is lifted (the tolerance varies from model to model) the safety drive speed is automatically activated (all models of this handbook have passed the stability Tests in compliance with standard EN280:2001).
- Drive the machine with lifted platform only on flat grounds, verifying the absence of holes or steps on the floor and bearing in mind the overall dimensions of the machine.
- Backward drive (in the direction of the fixed wheels) does not allow the operator a complete visibility from the control position. This operation shall be carried out with the utmost care.
- While driving the machine with lifted platform the operators are not allowed to place horizontal loads onto the platform (operators on board must not pull ropes, wires, etc.).
- The machine must not be used directly for road transport. Do not use it for material transport (see chapter "Intended use").
- Do not operate the machine if components boxes are not properly closed.
- Check that in the operating area there are not obstacles or other dangerous elements.
- Pay particular attention to the area above the machine during lifting to avoid any crushing and collisions.



3.3.3 Operating procedures

- The machine is equipped with an inclination control system disabling lifting in case of unstable positioning. Working operations can be resumed only after placing the machine in a steady position. Should the audible alarm and the red light on the platform control panel turn on, the machine is not correctly positioned (see paragraphs relevant to "Use instructions"). Bring it to safety rest position before starting operations again. If the tilt alarm is activated with platform lifted, the only possible platform operation is lowering.
- The machine is equipped with a platform overload controller disabling the platform lifting and lowering in case of overloading. In case of platform overloading when lifted, also drive is disabled. Platform operation can be resumed only after removing the exceeding load. Should the audible alarm and the red light located on the platform control panel turn on, then the platform is overloaded (see chapter "Red warning light overload"). Remove the exceeding load before starting operations again.
- The machine is equipped with a device to avoid the risk of shearing and crushing in the lifting structure in compliance with EN280:2001: the lowering movement is automatically stopped in a position where the vertical distance between the scissor ends is over 50 mm. In this condition the movement alarm warns about the danger condition by increasing its frequency. The operator on board the platform must release the lowering control and wait for the audible alarm to go off (about 3 sec.), before continuing lowering movement, performed as follows: the audible alarm and warning device (where fitted) immediately trip, at a higher frequency than normal, while movement is delayed by about 1.5 seconds. The above procedure also starts every time the lowering control is given at a platform height below that of automatic stop. (see "Lifting and lowering" chapter)
- The machine features a device for checking the state of battery charge (battery protection device): when battery charge is at 20% the operator on the platform is informed of this condition through a flashing red light. In this condition lifting is disabled, battery should be immediately charged.
- Do not lean over the platform guard rails.
- Make sure that no people, apart from the operator, are in the area where the machine is operating. While moving the platform, the operator on board should pay particular attention to avoid any contact with the personnel on the ground.
- During operations in public areas, in order to prevent people other than the personnel from approaching the machine and being endangered, surround the working area by means of barriers or other suitable signs.
- Avoid severe weather conditions and, in particular, windy days.
- Lift the platform only if the machine is resting on solid and horizontal surfaces (see following chapters).
- Drive the machine with lifted platform only if the ground is solid and horizontal.
- After each work session, always take the keys out of the control panels and keep them in a safe place to prevent unauthorized people from using the machine.
- Always place working tools in a steady position to prevent them from falling and hurting the operators on the ground.



When choosing the positioning point of the chassis, to prevent unexpected possible contacts with obstacles, always observe the figures carefully as these make it possible to identify the range of action of the platform (chap. 2).

3.3.4 Wind speed according to BEAUFORT SCALE

You can use the table below for a simple assessment of the wind speed. We remember that the max. limit for each machine model is indicated in the table TECHNICAL FEATURES OF STANDARD MACHINES.



The machines for which the max. wind limit is 0 m/s must be used indoors only. These machines cannot be used outdoors even with no wind.

Beaufort Number	Wind speed (km/h)	Wind speed (m/s)	Description	Sea conditions	Land conditions
0	0	<0.28	Calm	Flat	Calm. Smoke rises vertically.
1	1-6	0.28-1.7	Light air	Ripples without crests.	Wind motion visible in smoke.
2	7-11	1.7-3	Light Breeze	Small wavelets. Crests of glassy appearance, not breaking.	Wind felt on exposed skin. Leaves rustle.
3	12-19	3-5.3	Gentle breeze	Large wavelets. Crests begin to break; scattered whitecaps.	Leaves and smaller twigs in constant motion.
4	20-29	5.3-8	Moderate breeze	Small waves.	Dust and loose paper raised. Small branches begin to move.
5	30-39	8.3-10.8	Fresh breeze	Moderate (1.2 m) longer waves. Some foam and spray.	Smaller trees sway.
6	40-50	10.8-13.9	Strong breeze	Large waves with foam crests and some spray.	Large branches in motion. Whistling heard in overhead wires. Umbrella use becomes difficult.
7	51-62	13.9-17.2	Near gale / moderate gale	Sea heaps up and foam begins to streak.	Whole trees in motion. Effort needed to walk against the wind.
8	63-75	17.2-20.9	Fresh gale	Moderately high waves with breaking crests forming spindrift. Streaks of foam.	Twigs broken from trees. Cars veer on road.
9	76-87	20.9-24.2	Strong gale	High waves (6-7 m) with dense foam. Wave crests start to roll over. Considerable spray.	Larger branches break off trees, construction/temporary signs and barricades blown over, damage to circus tents and canopies.
10	88-102	24.2-28.4	Whole gale / Storm	Very high waves. The sea surface is white and there is considerable tumbling. Visibility is reduced.	Trees broken off or uprooted, saplings bent and/or deformed, poorly attached asphalt shingles and shingles in poor condition peel off roofs.
11	103-117	28.4-32.5	Violent storm	Exceptionally high waves.	Widespread vegetation damage, minor damage to most roof shingles/surfaces, gravel may be blown from flat roofs.
12	>117	>32.5	Hurricane	Huge waves. Air filled with foam and spray. Sea completely white with driving spray. Visibility greatly reduced.	Considerable and widespread damage to vegetation, a few windows broken, structural damage to mobile homes and poorly constructed sheds and barns.

3.3.5 Pressure of the machine on ground and load-bearing capacity of ground

Before using the machine, the operator must make sure the floor is suitable for withstanding the specific loads and pressures on the ground with a certain safety margin.

The following chart provides the parameters in play and two examples of calculation of the average pressure on the ground below the machine and max pressure underneath the wheels or outriggers (p1 and p2).

SYMBOL	U.M.	DESCRIPTION	EXPLANATION	FORMULA
P1	Kg	Machine weight	Represents the weight of the machine, not including nominal load. Note: always refer to the details indicated on the plates affixed to the machine.	-
M	Kg	Nominal load	The max. load allowed for the work platform.	-
A1	cm ²	Area occupied on the ground	Machine supporting area on the ground determined by the result of TRACK x WHEEL BASE.	$A1 = c \times i$
c	cm	Track	Cross width of machine measured outside the wheels. Or: Cross width of machine measured between outrigger centres.	-
i	cm	Wheel base	Longitudinal length of machine measured between wheel centres. Or: Longitudinal length of machine measured between outrigger centres.	-
A2	cm ²	Wheel or levelling outrigger area	Wheel or levelling outrigger ground support area. The wheel support area on the ground must be verified empirically by the operator; the levelling outrigger support area depends on the shape of the support foot.	-
P2	Kg	Max. load on wheel or levelling outrigger	This represents the max. load that can be discharged onto the ground by a wheel or by a levelling outrigger when the machine is in the worst position and load conditions. Note: always refer to the details indicated on the plates affixed to the machine.	-
p1	Kg/cm ²	Pressure on ground	Average pressure placed on the ground in idle conditions and supporting the nominal load.	$p1 = (P1 + M) / A1$
p2	Kg/cm ²	Max. specific pressure	Max. pressure which a wheel or a levelling outrigger can place on the ground when the machine is in the worst position and load conditions.	$p2 = P2 / A2$

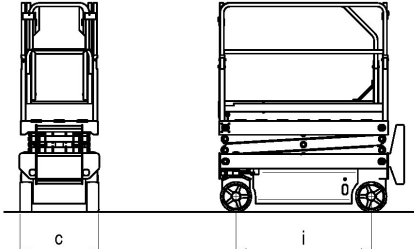

EXAMPLE 1: SCISSOR LIFT

P1 = 1395 kg
P2 = 680 kg
M = 250 kg
c = 76,5 cm
i = 132,0 cm
A1 = c x i = 10098 cm²
A2 = 71,5 cm²

$p1 = (P1+M)/A1 = 0,16 \text{ kg/cm}^2$
 $p2 = P2/A2 = 9,5 \text{ kg/cm}^2$

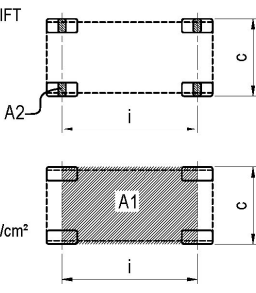

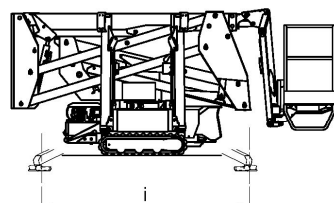

EXAMPLE 1: CRAWLER LIFT

P1 = 2200 kg
P2 = 920 kg
M = 200 kg
c = 295 cm
i = 295 cm
A1 = c x i = 87025 cm²
A2 = 62,8 cm²

$p1 = (P1+M)/A1 = 0,03 \text{ kg/cm}^2$
 $p2 = P2/A2 = 14,6 \text{ kg/cm}^2$

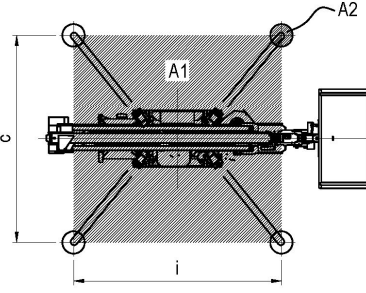

The table below shows the load-bearing capacity of the ground split up by ground type.

Refer to the data contained in the specific tables of each model (chapter 2, TECHNICAL FEATURES OF STANDARD MACHINES) to obtain the figure relating to the max pressure on the ground caused by the single wheel.



Using the machine is forbidden if the max pressure on the ground per wheel is above the load-bearing capacity of the specific type of ground on which the machine is to be used.

TYPE OF GROUND	BEARING CAPACITY IN Kg/ cm ²
Non compact filling earth	0 – 1
Mud, peat, etc.	0
Sand	1.5
Gravel	2
Friable earth	0
Soft earth	0.4
Rigid earth	1
Semi-solid earth	2
Solid earth	4
Rock	15 - 30

Should you have any doubts, verify the load-bearing capacity with specific tests.
In case of constructed surfaces (concrete floors, bridges, etc.) the load-bearing capacity must be provided by the builder.

3.3.6 High-voltage lines

The machine is not electrically insulated and is not protected in case of contact with or vicinity to power lines.
A minimum distance must be kept from the power lines according to applicable laws and the following table

Type of power lines	Voltage (KV)	Minimum distance (m)
Light poles	< 1	3
	1-10	3.5
	10 - 15	3.5
	15 - 132	5
	132 - 220	7
	220 - 380	7
High-voltage pylons	>380	15

3.4 Hazardous situations and/or accidents

- If, during Preliminary Operation Checks or when using the machine, the operator discovers a defect that could produce a hazardous situation, the machine must be placed in **safety condition** (isolate it and affix a notice) and the employer must be notified about the fault.
- If, during use, an accident occurs, with injury to the operators, caused by operating errors (e.g., collisions) or any structural yielding, the machine must be placed in **safety condition** (isolate it and affix a notice) and the employer must be notified about the fault.
- In case of an accident with injuries to one of more operators, the operator on the ground (or on a platform not involved in the accident) must :
 - **Seek help immediately.**
 - Perform the operation to return the platform to the ground **only if he is certain this will not make the situation worse.**
 - Place the machine in **safety condition** and notify the fault to the employer.

4. INSTALLATION AND PRELIMINARY CHECKS

The machine is supplied completely assembled, therefore it can perform all functions in safety as provided for by the manufacturer. No preliminary operation is required. To unload the machine, follow the instructions in chapter "Handling and carrying". Place the machine on a sturdy enough surface (see paragraph 3.3.5) and with a gradient below max. allowed gradient (see technical features "Stability limits").

4.1 Becoming acquainted with the machine

Anyone wishing to use a machine with weight, height, width and length characteristics or which generally differs significantly from the training received must be updated in order to cover the differences.

The employer shall be responsible for ensuring all the operators who use work equipment are adequately trained and in order with applicable health and safety legislation.

4.2 Preliminary operation checks

Before using the machine read the instructions given in this manual and the concise instructions indicated on the platform plate.

Check the perfect integrity of the machine (by sight check) and read the plates showing machine operating limits.

Before using the machine the operator must always check visually that:

- The battery is completely charged.
- The oil level lies between the min. and max. value (with lowered platform).
- The ground is sufficiently horizontal and solid.
- The machine carries out all operations in safety.
- The wheels and drive motors are properly fixed.
- The wheels are in good condition.
- Make sure the guard rails are fastened to the platform and the gate/s are in automatic reclosing mode.
- The structure does not show clear faults (visually check welding of lifting structure).
- The instructions plates are perfectly readable.
- The platform control panel and the ground emergency control panel, dead-man system included, are perfectly efficient.

Do not use the machine for purposes different from those it was intended for.

5. USE INSTRUCTIONS

Before using the machine read this chapter thoroughly.



WARNING!

Follow exclusively the instructions given in the next paragraphs and the safety rules described both hereafter and in the previous paragraphs. Read the next paragraphs carefully in order to properly understand the on/off procedures as well as all operations and their correct use.

5.1 Platform control panel

The control panel is located on the platform. The control panel is fixed to the right guard rail and is used to:

- turn the machine ON/OFF
- select the operating mode (lifting/lowering or drive)
- move the platform during ordinary working procedures
- display some parameters (alarms, dead-man's working, etc...)

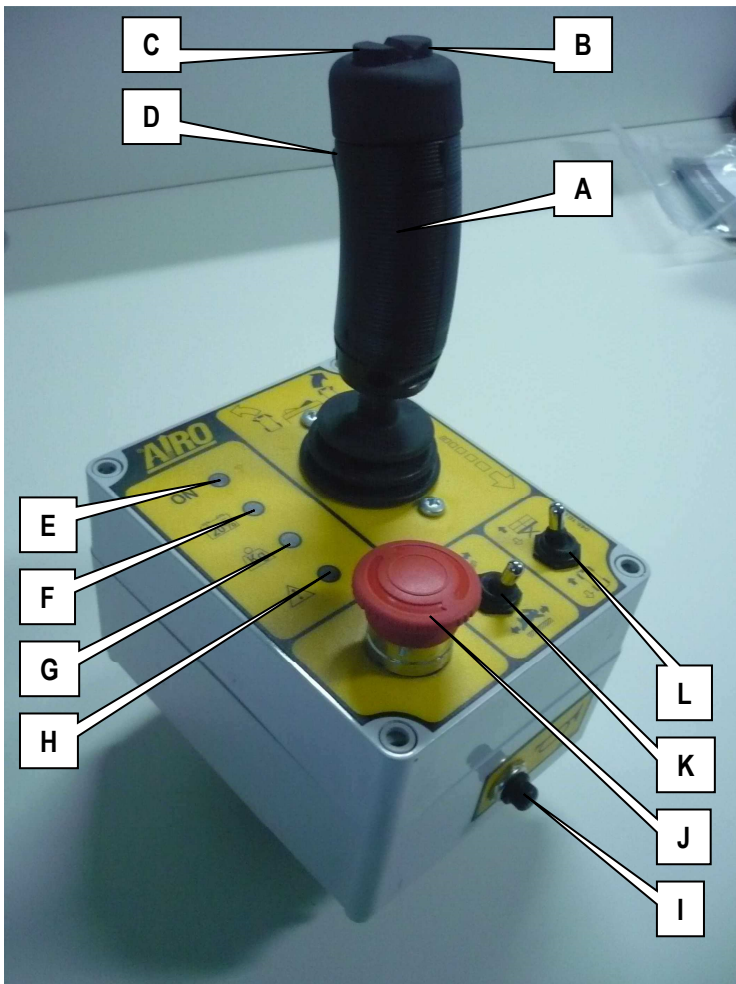

- A. Proportional joystick control for platform drive / lifting / lowering
- B. Switch for "RIGHT" steering
- C. Switch for "LEFT" steering
- D. Dead-man switch
- E. Enabled control panel warning light
- F. Flat battery warning light
- G. Platform overload warning light
- H. Danger warning light due to instability or malfunctioning of the electric system
- I. Horn switch
- J. Emergency stop button
- K. Drive speed selector (hare/snail)
- L. Movement selector (drive or lifting/lowering)

5-1: Platform control panel

All movements (steering excluded) are controlled by proportional joystick control; it is therefore possible to adjust movement speed by means of the relative controls (except lowering which occurs by gravity). To avoid sudden shakes during movements, it is advisable to operate the proportional joystick controls gradually.

For safety reasons, to operate the machine, press dead-man switch **D** on the front part of the proportional joystick before activating the joystick. If the dead-man switch is accidentally released while the machine is operating, the movement is immediately stopped. To resume the operation, release the joystick and follow the steps described above.



WARNING!

Holding down the dead-man switch for over 10 seconds without carrying out any operation will disable the control panel. The green led (E) is OFF in this condition. To operate the machine again release the dead-man switch and press it again. Now, the green led (E) will light up steady and for the next 10 seconds all controls will be enabled.

5.1.1 Drive and steering



Before any movement, verify the presence of people in close proximity to the machine and, in any case, proceed with the utmost caution.



It is forbidden to drive the machine when platform is lifted unless the ground is flat and steady with no holes and/or steps.

The controls used to move the machine (refer to figure 5-1) are:

- | | |
|---|----------|
| ▪ Joystick control | <u>A</u> |
| ▪ Movement selector (drive or lifting/lowering) | <u>L</u> |
| ▪ Switch for "RIGHT" steering | <u>B</u> |
| ▪ Switch for "LEFT" steering | <u>C</u> |
| ▪ Drive speed selector (hare/snail) | <u>K</u> |
| ▪ Dead-man switch | <u>D</u> |

To drive the machine carry out the following operations in sequence:

- select "drive" mode with selector **L**
- press dead-man switch **D** (the green led **E** will light up steady indicating its enabling)
- within 10 seconds from the green steady led lighting up, set the proportional joystick control **A** forward for forward drive or backward for reverse drive by holding down the dead-man switch as long as the movement has been carried out.

By means of the speed selector **K** you can select two drive speeds:

- low speed with selector in "Snail" position
- high speed with selector in "Hare" position

To steer use steering switches **B** or **C** while activating dead-man switch **D**; press button **B** for right steering and button **C** for left steering.

NOTE:

To achieve maximum drive speed, set speed selector **K** to position "Hare", and activate joystick control **A**.

To drive the machine on steep upward or downward slopes (for instance, while loading/unloading the machine onto/from a truck) set speed selector **K** to position "Snail" and activate joystick control **A**.

With platform lifted, **safety drive speed** is automatically enabled regardless of the position of speed selector **K**.

5.1.2 Drive with operator on the ground

If drive operations are to be carried out not from the preset control panel on the platform (e.g. transit through doors where the machine height is too high) you can proceed as follows:

- Lower the machine completely.
- Remove the platform control panel.
- If necessary, remove or fold down the guard rails to further reduce the overall height.
- Select the slow drive speed ("Snail").
- Carry out the movements at a safety distance from the machine of at least 1 metre.
- Pay attention to the directions of drive and steering, keeping in mind that the indications on the "platform control panel" refer to its preset position (fixed to the guard rails).



IT IS FORBIDDEN
To lift/lower the machine using the ground control panel

5.1.3 Platform lifting and lowering

The following controls are to be used to lift and lower the platform (see **FIGURE 5-1**):

- joystick control A
- movement selector L
- dead-man switch D

To lift/lower the platform carry out the following operations in sequence:

- Select "lift/lower" mode with selector **L**.
- Press dead-man switch **D** (the green led **E** will light up steady indicating its enabling).
- Within 10 seconds from the green steady led **E** lighting up, set proportional joystick control **A** forward for lifting or backward for lowering by holding down dead-man switch **D** as long as the movement has been carried out.

Platform lowering is performed at fixed speed.

NOTE:

The machine is equipped with a device to avoid the risk of shearing and crushing in the lifting structure in compliance with "EN280:2001".

The lowering movement is automatically stopped in a position where the vertical distance between the scissor ends is over 50 mm. In this condition the movement alarm warns about the danger condition by increasing its frequency. The operator on board the platform must release the lowering control and wait for the audible alarm to go off (about 3 seconds) before continuing lowering movement, performed as follows: the audible alarm and warning light (where fitted) immediately trip, at a higher frequency than normal, while movement is delayed by about 1.5 seconds.

The above procedure also starts every time the lowering control is given at a platform height below that of automatic stop.



Before carrying out any **LIFTING** or **LOWERING** operation, verify that no people are in proximity of the machine and in any case proceed with the utmost caution.

5.1.4 Manual extension of the platform

The extension of the mobile platform is carried out manually. To extend the mobile platform (Figure 5-2):

- press lock pedal **A**
- manually push the platform from the inclined part of the guard rails while holding down pedal **A**
- release pedal **A** close to one of the provided slots depending on the extension you wish to achieve
- make sure that lock pedal **A** is actually inserted into the slot to be sure that the mobile platform is blocked.

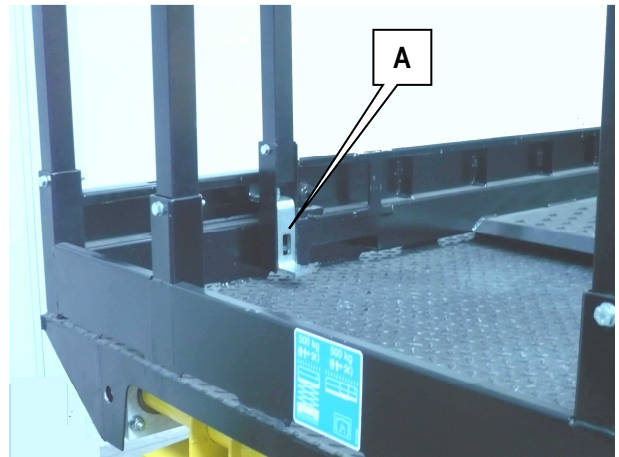

5-2: Mobile platform extension unlock pedal

5.1.5 Other functions of the platform control panel

5.1.5.1 Manual horn

I – Figure 5-1 : Horn to warn that the machine is moving. The manual operation of the horn is carried out by pressing key I

5.1.5.2 Emergency STOP button

J - Figure 5-1: By pressing the red emergency **STOP** button all control functions of the machine are stopped. Normal functions are enabled by rotating the button of 1/4 turn clockwise.

5.1.5.3 Green warning light, control panel enabled

E - Figure 5-1: Lit up flashing when the machine is turned on: If the platform control panel has been selected and this light flashes the controls are not enabled because the dead-man switch **D** is not pressed or it was pressed for more than 10 seconds and no operation was performed.

Lit up steady with machine on and dead-man switch **D** pressed for less than 10 seconds: With platform controls, all controls are enabled (unless other warnings are present).

5.1.5.4 Red warning light, flat battery

F - Figure 5-1: Flashing when battery is charged at 20% only. In this condition, lifting is disabled. Batteries should be immediately recharged.

5.1.5.5 Red warning light, overload

G - Figure 5-1: Lit up steady with activation of audible alarm with a platform overload exceeding 20% the nominal load. If platform is lifted, the machine is completely locked. If platform is lowered all driving/steering operations are still possible but lifting is disabled. Remove the overload before using the machine again.

Fast flashing with audible alarm activated in case of fault in the platform overload controller. With lifted platform the machine is completely blocked.

5.1.5.6 Red warning light, danger due to instability or drive control disable

H - Figure 5-1: Lit up steady with activation of audible alarm when the machine is not perfectly levelled. Lifting movement is no longer possible (nor drive if platform is lifted). To use the machine again lower the platform completely and position the machine on an even ground to ensure its stability.

Or, in condition of platform lifted, with one or both pot-hole guards not lowered, drive control is disabled.

5.2 Ground control panel

The ground control panel is located on the chassis (see paragraph "Location of main components") and is used to:

- turn the machine ON/OFF
- select the control panel (ground or platform)
- operate the platform in emergency cases
- display some working parameters (work hours, battery charge level, etc...)



IT IS FORBIDDEN

To use the ground control panel as a workstation when personnel is on the platform.



Use the ground control panel only to start/stop the machine, to select the control panel or in emergency situations to allow the platform to be recovered.



The key must be given to authorized personnel. Keep a duplicate key in a safe place. Always remove the on/off key at the end of work shifts.

- A. Hour-meter / battery protection voltmeter
- B. Emergency STOP button
- C. On-off key / control panel selection
- D. Enabled control panel warning light
- E. Platform lifting/lowering lever
- F. Fuse
- G. Movement alarm



5-3: Ground control panel

5.2.1 Hour meter / battery protection voltmeter (A)

The hour-meter displays the working hours of the electric pump. Platform lowering occurs by gravity and does not require the switching on of the electric pump, therefore the time used for this operation is not counted by the hour-meter.

The function of the battery protection Voltmeter is for preserving the battery, avoiding it from discharging excessively. Once the battery has reached a discharge level of 20%, the control system informs the operator on board of this condition through the red flashing led (previously described). Lifting is disabled and batteries must be recharged. On the ground control panel, the condition of flat battery is reported in the following way:

- the last two leds on the left flash alternatively if the indicator is round-shaped
- only the last two small squares are lit if the indicator is a LCD display

5.2.2 Emergency stop button (B)

If you press this button, the machine is completely switched off. By rotating it of 1/4 turn (clockwise) the machine can be turned ON by means of the ON-OFF key.

5.2.3 On-off key / control panel selection (C)

The on-off key located on the ground control panel is used to:

- turn ON the machine by selecting one of the two control panels:
 - platform control panel enabled with locking key switch set to platform symbol. Stable position with possibility to extract the key
 - ground control panel enabled (for emergency operations) with locking key switch set to chassis symbol. Position with action to be kept. When the key is released the machine is turned off
- turn OFF the control circuits by turning it to OFF. Stable position with possibility to extract the key

5.2.4 Enabled control panel warning light (D)

The green light is ON when the machine is turned ON and the ground control panel is enabled (the on/off key (C) should be kept in chassis position).

5.2.5 Platform lifting/lowering lever (E)

This lever is to be used to lift or lower the platform. This control can be operated only if the on-off key is set to ON downwards (ground control panel selected). We shall also remind you that the ground control panel is to be used to operate the platform only in emergency situations and must not be used for any other purposes.

5.2.6 Movement alarm

The machine has a movement alarm that is activated as follows:

- always with intermittent sound, every 2 seconds approx., to indicate any movement of the machine
- with intermittent sound every 0.5 seconds to indicate the danger of being trapped in the lifting structure during the last section of the lowering movement (see par. "Platform lifting/lowering").

5.3 Platform access

The “access position” is the only one from which loading or unloading of persons and materials is allowed. The “access position” to the work platform is the completely lowered configuration.

To access the platform (Figure 5-4):

- get on ladder **A** hanging on to the rungs, the ladder stringers or the entry guard rail stringers
- raise bar **B** and get on board

Check that, once you are on the platform, the bar falls down closing the access. Fasten the safety harness to the provided hooks.

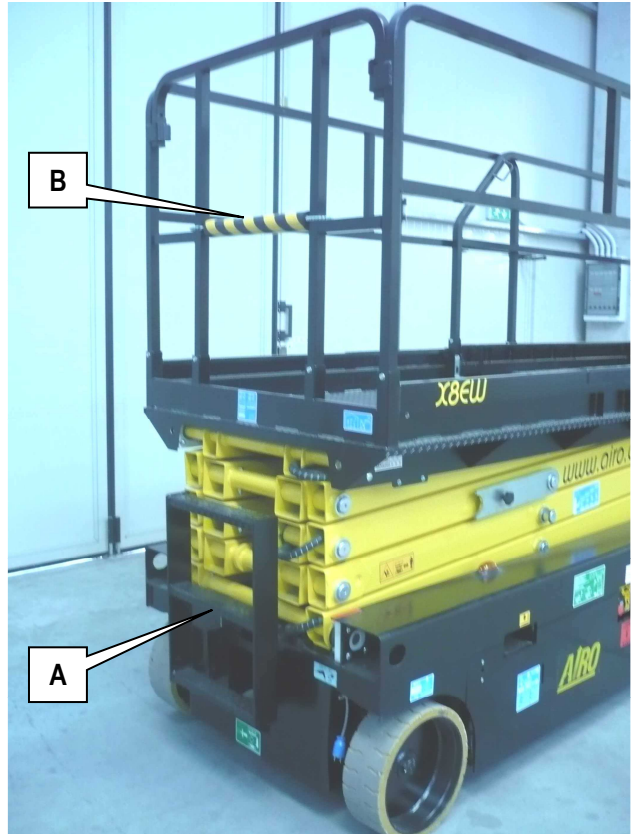

5-4: Platform access position/leaving position



To get on the platform use only the access equipment the platform is provided with. When moving up or down, always keep your eyes on the machine and hold onto the entry stringers.



IT IS FORBIDDEN
To block the closing bar so as to keep the platform access door open.



IT IS FORBIDDEN
To leave or access the work platform unless this is in the position required for access or leaving.

5.4 Machine start-up

To start the machine the operator shall:

- Release the emergency stop button located on the ground control panel by rotating it of 1/4 turn clockwise.
- Turn the on-off key on the ground control panel to "Platform" position.
- Remove the starting key and hand it over to a person in charge on ground, properly informed of the use of the emergency controls.
- Get onto the platform.
- Release the emergency stop button on the platform control panel (see previous paragraphs).

At this point the various functions can be performed by thoroughly following the instructions given in the previous paragraphs.



To turn on the machine, the battery charger must be disconnected from the mains (see paragraph 7.4.3). If the battery charger is working, the machine is off and cannot be turned on.

5.5 Machine stop

5.5.1 Normal stop

During the normal stop of the machine, if you release the controls, the operation is stopped. Stop occurs within a time limit set in the factory, which guarantees smooth braking.

5.5.2 Emergency stop

Should it be necessary, the operator may immediately stop all machine functions on both platform and ground control panel.

On the platform control panel press the emergency stop button and the machine is turned off.

On the ground control panel:

- press the emergency stop button on the ground control panel and the machine will be turned off
- by pulling out the power connector (Figure 5-5) (battery side) the machine power is cut out (power circuit cut-out).

To resume the operations:

- On the platform control panel turn the emergency stop button by a $\frac{1}{4}$ of turn clockwise.
- On the ground control panel turn the emergency stop button by a $\frac{1}{4}$ of turn clockwise and insert the connector thoroughly to power the machine again.

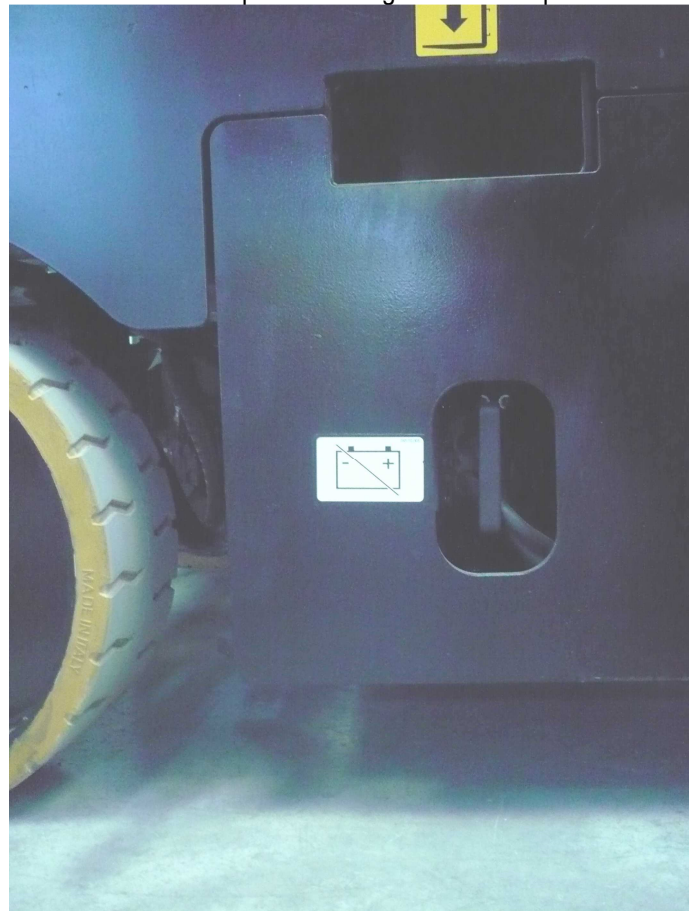

5-5: Power connector

5.6 Manual emergency lowering



IT IS FORBIDDEN
to use the manual emergency lowering control to lower the platform with overloads.

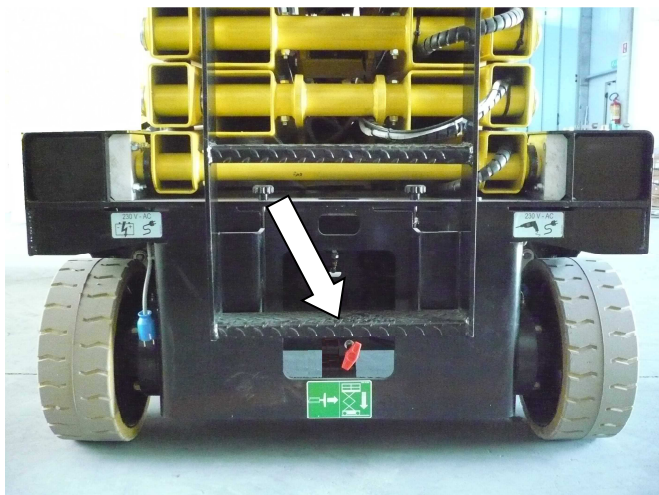

5-6: Manual emergency lowering with one knob

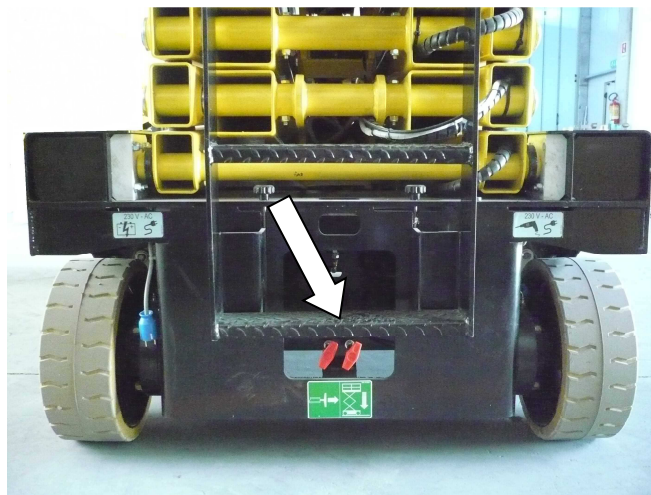

5-7: Manual emergency lowering with two knobs

In case of fault in the electric or hydraulic system, to carry out the manual emergency lowering procedure pull out the knob indicated in the (Figure 5-6).

Where two knobs are present, these should be activated both of them according to the sequence shown in the plate (Figure 5-7). Attention, the emergency control can be stopped at any time by releasing the knob.



This function is to be used only in emergency situations when no motive power is available.

5.7 Socket for electric tool connection (optional)

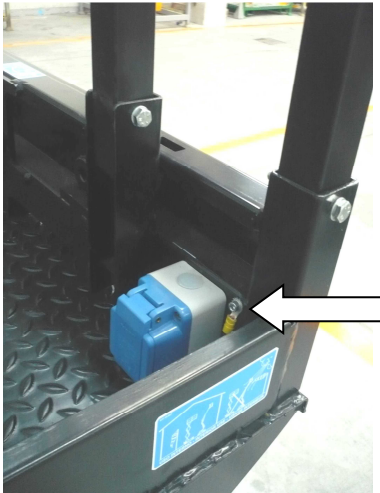

5-8: Platform current socket

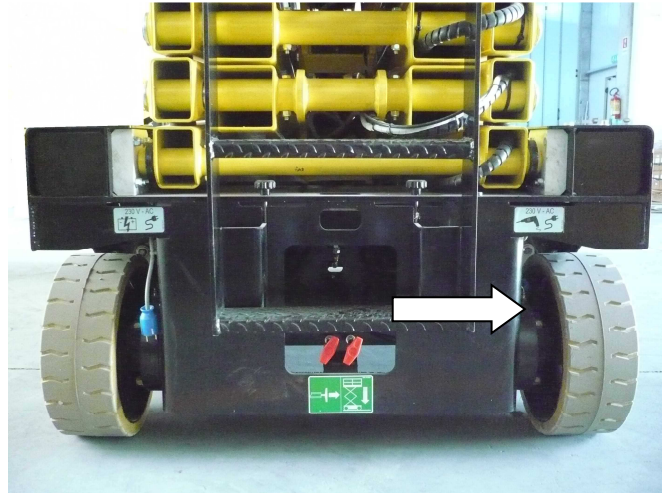

5-9: Electric line connection plug

The work platform can be equipped with a socket (230V Ac) enabling the operator to connect the electric tools necessary to carry out his operations.

To activate the electric line (see pictures above) introduce a cable into the plug connected to the 230V AC 50 Hz mains, with all protections according to the current standards in force.

The plugs and sockets equipped on standard machines comply with EEC standards and can therefore be used in EU member countries. On request the machine can be equipped with plugs and sockets in compliance with local standards or with particular needs.

Connect to the power mains having the following features:

- Power voltage 230V \pm 10%.
- Frequency 50÷60 Hz.
- Activated grounding line.
- Working protection devices according to current standards in force.
- Do not use extension leads exceeding 5 metres to connect to the mains.
- Use a cable of suitable section (min 3x2.5 mm²).
- Do not use rolled-up cables.



5.8 End of work

After stopping the machine according to the instructions given in the previous paragraphs:

- Always set the machine to rest position (platform completely lowered).
- Press the emergency Stop button on the ground control panel.
- Remove the keys from the control panel to prevent unauthorized people from using the machine.
- Recharge the battery according to the instructions given in section "Maintenance".

6. HANDLING AND CARRYING

6.1 Handling

To handle the machine in normal operating conditions follow the instructions given in chapter "USE INSTRUCTIONS" under paragraph "Drive and steering".

When platform is completely lowered (or within a given height according to specific needs and further to checks) the machine can be handled (i.e. drive can be performed) at different speeds to be freely selected by the user.

When platform is lifted and exceeds a given height, machines with lowered pot-hole guards can be driven only at a lower speed (automatically reduced) up to the height specified in chapter "Technical Features".

It is important to make sure that the pot-hole guards function properly and there are no objects in the area where the device is operating.

WARNING!



Drive with lifted platform may be subject to different restrictions according to the country where the machine is used. Find out about the legislative limits concerning this operation from the bodies of Health and Safety at work.



It is absolutely forbidden to drive the machine when platform is lifted unless the ground is horizontal, flat and steady.



Before any movement, verify the presence of people in close proximity to the machine and, in any case, proceed with the utmost caution.



Backward drive (in the direction of the fixed wheels) does not allow the operator a complete visibility from the control position. This operation shall be carried out with the utmost care.



Before any movement make sure that the machine plugs are disconnected from the power source.



Check that there are no holes and/or steps on the floor and bear in mind machine overall dimensions.



If the machine while travelling hits a hump or a hole with platform lifted (pot-hole guards lowered and safety speed enabled), the machine will rest on one or both guards with no danger to the operator. Now, if you lower the platform completely, and both driving wheels are lifted from the ground, the machine might not be able to quit the lock condition with its own means. Emergency towing is necessary (see par. "Emergency towing").



Do not use the machine to tow other vehicles.



While the machine is being displaced with lifted platform, no horizontal loads can be loaded onto the platform (operators on board are not allowed to pull wires or ropes, etc.).

6.2 Carrying

In order to carry the machine to the various working sites, follow the instructions given below. Considering the large dimensions of some models, before carrying, it is recommended to inquire about the overall dimension limits for road transport in force in your country.



Before carrying the machine, turn it off and remove the keys from the control panels. No people are allowed in proximity to or on the machine to avoid any risks deriving from sudden movements. For safety reasons never lift or tow the machine by means of its arms or platform. Loading operations are to be carried out on a flat surface with a suitable capacity, after setting the platform to rest position.

To carry the machine the operator shall load it onto a vehicle either:

- **By means of loading ramps and translation controls** located on the platform he can load it directly onto the vehicle (if ramp slope is within the gradeability described in paragraph "TECHNICAL FEATURES" and ramp capacity is adequate to weight) according to the instructions given in paragraph "GENERAL USE RULES" under paragraph "Drive and steering" for correct operation of drive controls. If the slope exceeds the gradeability, the machine is to be towed by means of a windlass only if the operator on the platform simultaneously activates the drive control to release the parking brakes or the machine is in towing mode (see par. Emergency towing).

The gradient can be determined using an electronic level or empirically as described below: position a wood board of known length on the gradient to be measured. Position a spirit level on the wood board and lift the downstream extremity of the latter until it is level. Now measure the distance between the board and the ground (**A**), divide this by the length of the board (**B**) and multiply by 100. The following image sums up the method.

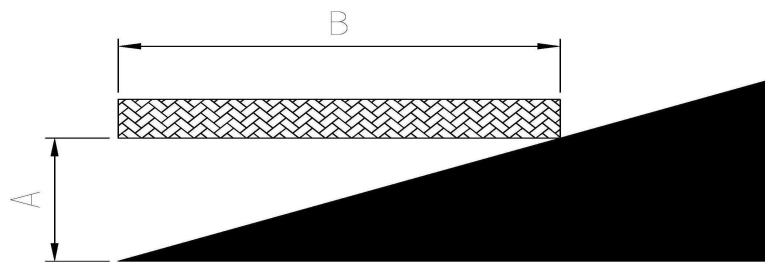

- **Through the 4 fastening holes** located on the 4 angles of the machine, it can be lifted by means of hooks and steel ropes (with safety factor = 5, see machine weight in Technical Features) connected to the provided holes as indicated in the figure 6-1
- **Through a lift truck** of a suitable capacity (see machine weight in table "Technical features" at the beginning of this manual) equipped with forks having at least the same length as the machine width. Insert the forks as indicated by the stickers on the machine (see figure 6-2). Should these stickers be not available, **DO NOT** lift the machine by means of a lift truck. Lifting the machine by means of a lift truck is a dangerous operation, which must be carried out by qualified operators only.



6-1: Fastening holes

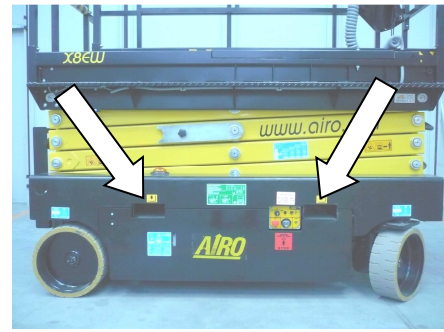

6-2: Forks chocks



After placing the machine onto the carrying vehicle, fasten it by means of the same holes used for lifting. To avoid breaking the platform overload controller, thus causing the machine to stop, **DO NOT fix the machine to the vehicle base by tying the platform (any model) or the last lifting arm.**



Before carrying the machine check the stability grade. The platform must be fully lowered and the platform extension must be in retracted position to ensure adequate stability during the entire operation.

6.2.1 Removable guard rails

Standard machines are fitted with guard rails which can be removed from the platform. Removing the guard rails it is possible to reduce the height of the machine for:

- carriage
- passage through lowered areas (e.g. doors).

To remove the guard rails remove the fixing screws.

Make sure the guard rails are properly secured before using the machine.

WARNING!

This operation is only for reducing the height of the stowed machine to facilitate carrying operations. It is absolutely forbidden to lift the unit with personnel on the platform if the guard rails are not raised and fixed.



6-3: Removable guard rails

6.2.2 Fold-down guard rails (optional)

The machine can be fitted with guard rails (optional) folding down to the inside of the platform. By folding down the guard rails the machine height can be reduced for:

- carriage
- passage through lowered areas (e.g. doors).

To fold down the guard rails, referring to the pictures of the next page:

1. extend the mobile platform and lock it in the indicated position
2. remove the control panel
3. raise and turn the front guard rail to the inside
4. remove the locking pins of the two side sliding guard rails
5. turn to the inside and press downwards the side sliding guard rails
6. remove the locking pins of the entrance guard rail
7. raise and turn the entrance guard rail to the inside
8. remove the locking pins of the two fixed side guard rails
9. lift and turn the two side fixed guard rails to the inside
10. retract the deck extension.

To restore the initial condition, repeat the a.m. operations in reverse order.
Make sure the guard rails are properly secured before using the machine.

WARNING!



THIS OPERATION IS ONLY FOR REDUCING THE HEIGHT OF THE STOWED MACHINE TO FACILITATE CARRYING OPERATIONS. IT IS ABSOLUTELY FORBIDDEN TO LIFT THE UNIT WITH PERSONNEL ON THE PLATFORM IF THE GUARD RAILS ARE NOT RAISED.

GUARD RAILS FOLDING-DOWN SEQUENCE



1



2



3

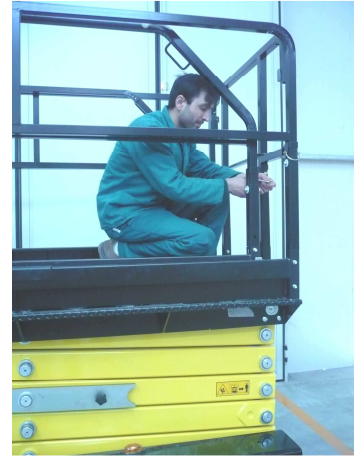

4



5



6



7

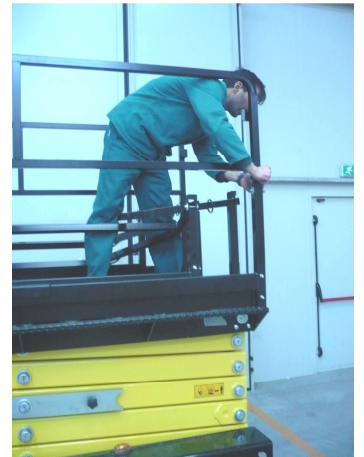

8



9



10

6.3 Emergency towing of the machine

In the event of a fault, carry out the following operations to tow the machine:

- Hook the machine to the provided holes (the same used for lifting – see previous pictures).
- Screw knob **B** completely on the hydraulic block.
- Screw lever **C** on manual pump **A**.
- Activate the manual pump until the control is bound; by doing so the parking brakes are unlocked.
- Tow at a very reduced speed (remember that in these conditions the machine does not brake).

At the end of towing operation, resume initial conditions:

- Unscrew knob **B** completely.
- Remove lever **C** from the manual pump and set it to the position as shown in the figure.

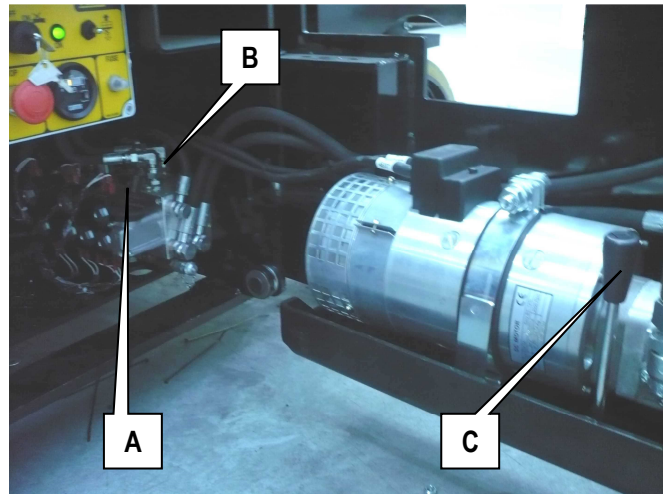

6-4: Emergency towing



Tow at a very reduced speed (remember that in these conditions the machine does not brake).

Tow only on a flat ground.

Do not park the machine without brakes on. Should the brakes be completely out of order put wedges under the wheels to prevent the machine from moving accidentally.

7. MAINTENANCE



- Always carry out maintenance operations when the machine is still, after having removed the key from the control panel, and with the platform in rest position.
- The maintenance operations described below refer to a machine with ordinary working use. In Case of difficult conditions of use (extreme temperatures, corrosive environments, etc.) or following long machine inactivity, it will be necessary to contact the AIRO assistance service to change the intervention schedule.
- Repairs and maintenance operations are to be carried out by trained and authorised personnel only. All maintenance operations should be carried out in compliance with the current work safety regulations (work places, personal protection devices, etc...).
- Carry out only the maintenance and adjustment operations described in this user manual. In emergency situations (e.g. breakdown, wheels replacement) contact Our Technical Support.
- During interventions, check that the machine is completely blocked. Before carrying out maintenance operations inside the lifting structure, check that this is off-line in order to avoid accidental lowering of the arms (chapter "Safety stop").
- Remove the battery cables and provide batteries with a suitable protection during welding operations.
- In case of replacement, use original spare parts only.
- Disconnect the 230V AC and/or 380V AC sockets, if any.
- The lubricants, hydraulic oils, electrolytes and all detergent products should be handled with care and disposed of in safety according to the current regulations. A prolonged contact with the skin may cause irritations and dermatosis; wash with water and soap and rinse thoroughly. Contact with eyes, especially with electrolytes, is also dangerous; rinse with water thoroughly and call the doctor.



WARNING!

NEVER MODIFY OR TAMPER WITH MACHINE PARTS TO IMPROVE THE MACHINE PERFORMANCE AS THIS MAY AFFECT ITS SAFE OPERATION.

7.1 Safety lock for maintenance operations

Before carrying out any maintenance or repairs to it, activate the lifting structure locking system.

Watch the pictures aside to understand how the lifting locking structure works before carrying out any maintenance or repairs to it.

- Unscrew knobs **B** completely (on both sides of the lifting structure)
- Rotate safety bars **A** by setting them in vertical position
- Lower the structure until it rests on bars **A** firmly
- Check the correct positioning of bars **A**

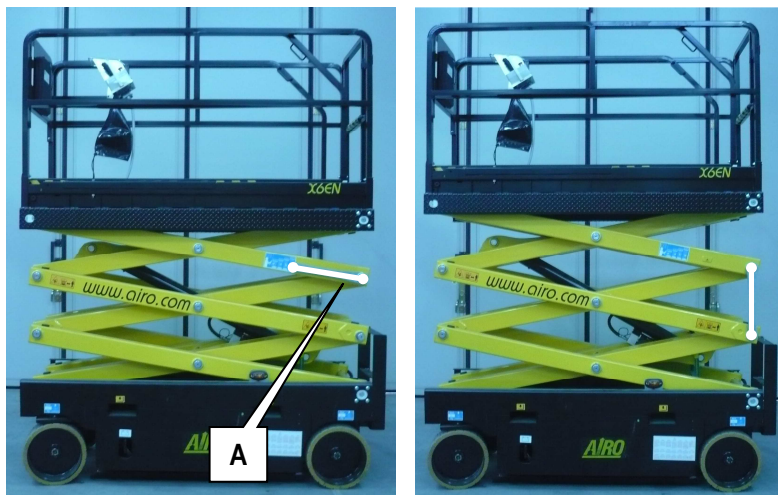

7-1: Locking of X8EN scissors

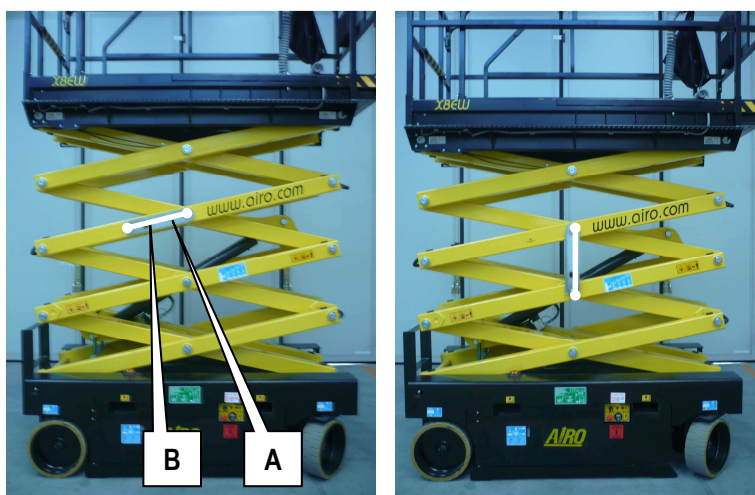

7-2: Locking of X10EN, X10EW, X10EW-WIND scissors

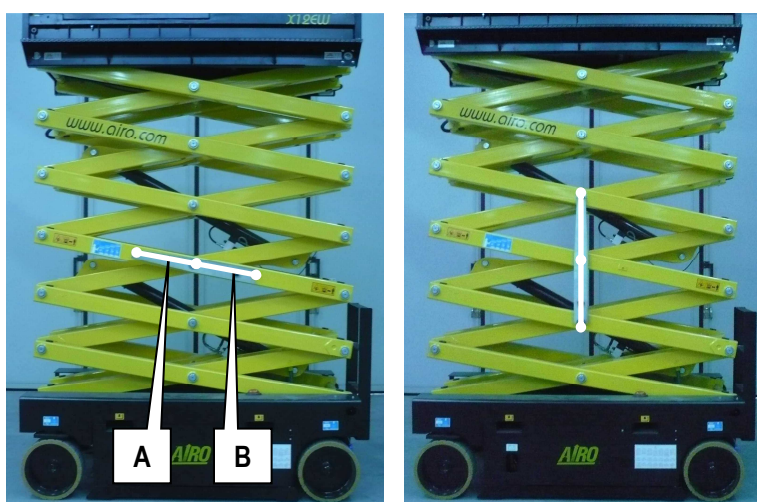

7-3: Locking of X12EN, X12EW, X12EW-WIND, X14EW scissors

7.2 Machine cleaning

To clean the machine use non-pressurized water jets after properly protecting the following parts:

- the control panels (both platform and ground)
- all electric boxes and electric devices in general
- the electric motors.



Do not use pressurized water jets (e.g. high-pressure cleaners) to clean the machine.

After washing the machine, always:

- Dry the machine.
- Check integrity of plates and stickers.
- Lubricate the articulated joints equipped with greaser and the sliding ways.

7.3 General maintenance

Below are listed the main maintenance jobs to be done and the relevant schedule (the machine features an hour meter).

OPERATION	FREQUENCY
Screw tightening (paragraph "Various adjustments")	After the first 10 working hours
Oil level check in hydraulic tank	After the first 10 working hours
Battery state (charge and liquid level)	Every day
Deformation of tubes and cables	Every month
Stickers and code plates	Every month
Articulated joints / sliding blocks greasing	Every month
Oil level check in hydraulic tank	Every month
Emergency devices efficiency check	Every year
Electric connections check	Every year
Hydraulic connections check	Every year
Periodic operation check and structure visual check	Every year
Screw tightening (paragraph "Various adjustments")	Every year
Pressure relief valve calibration check	Every year
Lifting circuit pressure relief valve calibration check	Every year
Braking valve efficiency check	Every year
Inclinometer operation check	Every year
Platform overload controller operation check	Every year
M1 Microswitch operation check	Every year
MPT1 and MPT2 Microswitches operation check	Every year
Dead-man switch check efficiency	Every year
Total oil change in hydraulic tank	Every two years
Hydraulic filter replacement	Every two years



IT IS NECESSARY

**TO SEND THE MACHINE TO THE MANUFACTURER WITHIN 10 YEARS OF WORK
FOR A COMPLETE CHECK.**

7.3.1 Various adjustments

Check the conditions of the following components and, if necessary, tighten (Figure 7-4):

- A. Wheels nuts and wheels nuts blocking pins
- B. Traction motor fixing screws
- C. Steering cylinder fixing screws
- D. Platform and guard rails fixing screws
- E. Lifting structure fixing screws
- F. Hydraulic fittings
- G. Arms pins locking nuts and rings
- H. Parking brakes fixing screws
- I. Mobile platform mechanical end stops

For torque wrench setting refer to the table below.

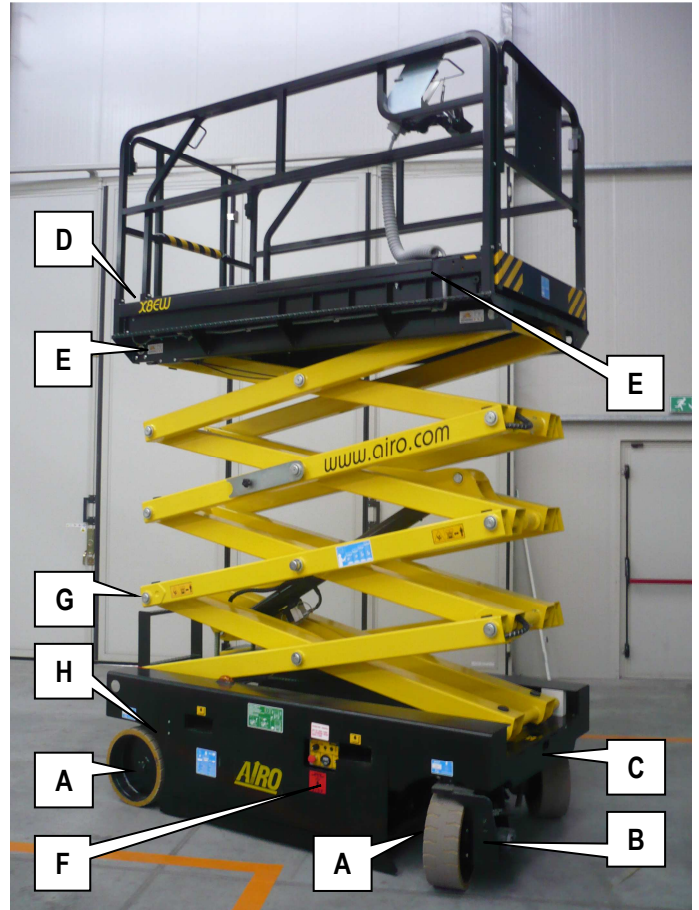

7-4: Location of parts to be adjusted

TORQUE WRENCH SETTING (S.I. thread, normal pitch)						
Class	8.8 (8G)		10.9 (10K)		12.9 (12K)	
Diameter	kgm	Nm	kgm	Nm	kgm	Nm
M4	0.28	2.8	0.39	3.9	0.49	4.9
M5	0.55	5.5	0.78	7.8	0.93	9.3
M6	0.96	9.6	1.30	13.0	1.60	16.0
M8	2.30	23.0	3.30	33.0	3.90	39.0
M10	4.60	46.0	6.50	65.0	7.80	78.0
M12	8.0	80.0	11.0	110	14.0	140
M14	13.0	130	18.0	180	22.0	220
M16	19.0	190	27.0	270	33.0	330
M18	27.0	270	38.0	380	45.0	450
M20	38.0	380	53.0	530	64.0	640
M22	51.0	510	72.0	720	86.0	860
M24	65.0	650	92.0	920	110	1100

7.3.2 Greasing

Grease all articulated joints equipped with greaser (or predisposition for greaser) at least every month.

At least once a month, using a spatula or a brush, lubricate the sliding guides (Figure 7-5) of:

- A. the sliding blocks of the extension structure on the chassis
- B. the sliding blocks of the extension structure under the platform
- C. the counter-pressure sliding blocks of the mobile platform.

At least once a month lubricate:

- D. the support pins of the steering wheels equipped with greaser.

Moreover, remember to grease all the points above mentioned:

- after washing the machine
- before using the machine again after a long time-interval
- after using the machine in adverse environmental conditions (high humidity levels; presence of dust; coastal areas, etc).

Before greasing, clean thoroughly using a wet cloth. Grease all points indicated in the picture aside (and all articulated joints equipped with greaser) with grease type:

ESSO BEACON-EP2, or similar.

(OPTIONAL BIODEGRADABLE OIL KIT)
PANOLIN BIOGREASE 2



7-5: Location of main parts to be greased

7.3.3 Hydraulic circuit oil level check and change

At least once a month check the tank level through the special window (Figure 7-6) and make sure it always lies between the min. and max. values. If necessary top up until max. level is reached. The oil check should be carried out when platform is completely lowered.

Completely change the hydraulic oil at least every two years.

To empty the tank (figure 7-7):

- lower the platform completely
- stop the machine by pressing the emergency stop button on the ground control panel
- disconnect the tubes from the tank
- unscrew flange **A** unlocking the screws with a Phillips screwdriver
- remove the tank from its seat after removing bar **C**
- pour the tank content in a suitable container, through the filler cap.

Use only the types of oil and quantity indicated in the table below.

HYDRAULIC SYSTEM OIL			
BRAND	TYPE		REQUIRED QUANTITY
	-20°C	+79°C	
SYNTHETIC OILS			
ESSO	Invarol EP46 30 LITRES	Invarol EP22	28 Litres
AGIP	Arnica 46	Arnica 22	
ELF	Hydrelf DS46	Hydrelf DS22	
SHELL	Tellus SX46	Tellus SX22	
BP	Energol SHF46	Energol SHF22	
TEXACO	Rando NDZ46	Rando NDZ22	
BIODEGRADABLE OILS - OPTIONAL			
PANOLIN	HLP SINTH E46	HLP SINTH E22	



Do not dispose of used oil in the environment. Comply with the current local standards.

The lubricants, hydraulic oils, electrolytes and all detergent products should be handled with care and disposed of in safety according to the current regulations. A prolonged contact with the skin may cause irritations and dermatosis; wash with water and soap and rinse thoroughly. Contact with eyes, especially with electrolytes, is also dangerous; rinse with water thoroughly and call the doctor.



7-6: Oil check window

7.3.3.1 Biodegradable hydraulic oil (Optional)

At the request of the customer, the machines can be supplied with biodegradable hydraulic oil compatible with the environment. Biodegradable hydraulic oil is completely synthetic, without zinc, non-polluting and highly efficient with saturated ester base, combined with special additives. The machines with biodegradable oil use the same component parts as standard machines, but the use of such type of oil is best taken into account from machine construction.

In case of wanting to change from mineral-oil based hydraulic oil to “bio” oil, the following procedure must be followed.

7.3.3.2 Emptying

Empty the hot hydraulic oil for entire system operation (oil tank, cylinders, large-volume pipes).

7.3.3.3 Filters

Change the filtering inserts. Use standard filters as indicated by the manufacturer.

7.3.3.4 Washing

After completely emptying the machine, fill with a nominal quantity of “bio” hydraulic oil.

Start the machine and perform all work movements at low revs for at least 30 minutes.

Empty the liquid inside the systems as indicated at 7.2.3.1.1.

Warning: During the entire washing procedure, avoid air entering the system.

7.3.3.5 Filling

After washing, fill the hydraulic circuit, bleed and check the level.

Bear in mind that contact of fluid with the hydraulic pipes can cause swelling.

Also remember that contact of fluid with the skin can cause reddening or irritation.

Also use suitable PPE during these operations (e.g., protective eyewear and gloves).

7.3.3.6 Commissioning / check

“Bio” oil behaves regularly, but it must be checked by taking a sample at set intervals according to the indications provided below:

CHECK FREQUENCY	NORMAL DUTY	HEAVY DUTY
AIRO	<i>Use and Maintenance Manual - X Series</i>	Page 54

1 st CHECK AFTER	50 OPERATING HOURS	50 OPERATING HOURS
2 nd CHECK AFTER	500 OPERATING HOURS	250 OPERATING HOURS
3 rd CHECK AFTER	1000 OPERATING HOURS	500 OPERATING HOURS
FOLLOWING CHECKS	1000 HOURS OR 1 OPERATION YEAR	500 HOURS OR 1 OPERATION YEAR

The fluid state is therefore constantly monitored, thus allowing its use until its features decay. Normally, in the absence of contaminating agents, the oil is never completely changed, but only occasionally topped-up.

The oil samples (at least 500ml) must be taken with the system at operating temperature. It is recommended to use new and clean containers.

The samples must be sent to the "bio" oil supplier. For more dispatch details, contact Your nearest distributor.

Copies of the analysis report must be kept in the check register. This is mandatory.

7.3.3.7 Mix

Mixtures with other biodegradable oils are not allowed.

The remaining amount of mineral oil must not exceed 5% of total filling quantity as long as the mineral oil is suitable for the same use.

7.3.3.8 Micro-filtration

When making the conversion on second-hand machines, always take into account the high dirt dissolution power of biodegradable oil.

After conversion, the dissolution of fault-causing deposits in the hydraulic system could occur. In extreme cases, washing the seal housings can cause greater leaks.

To prevent faults as well as avoid any negative effect on oil quality, after the conversion, it is best to filter the hydraulic system using a micro-filtration system.

7.3.3.9 Disposal

The biodegradable oil, inasmuch as saturated ester, is suitable for both thermal and material re-use.

It therefore provides the same disposal / re-use options as mineral based old oil.

Such oil can be incinerated whenever local laws allow.

Recycling the oil is preferable to disposal on dumps or incineration.

7.3.3.10 Topping up

The oil must **ONLY EVER** be topped up with the same product.

Note: Max water contamination is 0.1%.



During oil change or topping up, do not discard the hydraulic oil in the environment.

Hydraulic filter replacement

All models are equipped with suction filter inside the tank. It is advisable to replace it at least every two years.

To replace the suction filter inside the tank (figure 7-7):

- stop the machine by pressing the emergency stop button on the ground control panel
- disconnect the tubes from the tank
- unscrew flange **A** unlocking the screws with a Phillips screwdriver
- unscrew filter **B** from the suction tube and clean it with a detergent and a compressed air jet by blowing from the connection or replace the filtering element

to restore the initial condition, carry out the above-mentioned operation in reverse order.

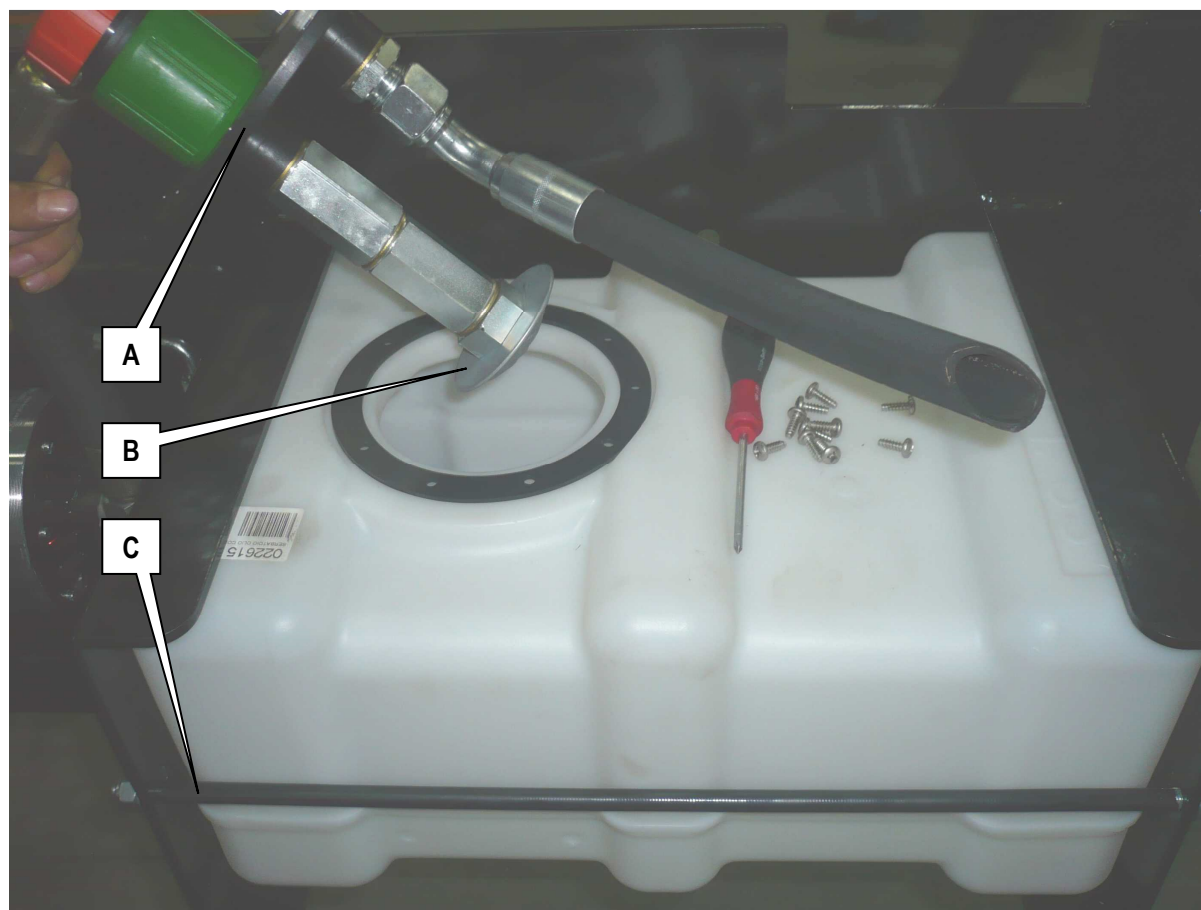

7-7:



Replace the filter using only original accessories available at our Technical Support. Do not re-use used oil and do not leave it in the environment, but dispose of in compliance with local standards in force.

Once the filter has been replaced (or cleaned), check the hydraulic oil level in the tank.

7.3.4 Pressure relief valve adjustment and operation check

The pressure relief valve controls the maximum pressure of the hydraulic circuit. Normally, this valve does not require any adjustment, since it is calibrated at the factory before the machine is delivered.

The pressure relief valve must be calibrated in the following cases:

- in case of replacement of the hydraulic block
- in case of replacement of the pressure relief valve only.

Check operation at least once a year.

To check the operation of the pressure relief valve (figure 7-8):

- Disconnect the power cords of the electric valves **EV2** and **EV3 (H and I)**.
- Introduce a pressure gauge with full scale of at least 250 bar in the special quick coupling (1/4" BSP) **D**.
- Using the platform control panel drive the machine forward and backward. Initially carry out the operation softly to check that the above mentioned valves have been disconnected properly (the machine should not move).
- Check the pressure value. The correct value is indicated in the chapter "**Technical features**".

To calibrate the pressure relief valve (figure 7-8):

- Disconnect the power cords of the electric valves **EV2** and **EV3 (H and I)**.
- Introduce a pressure gauge with full scale of at least 250 bar in the special quick coupling (1/4" BSP) **D**.
- Locate the pressure relief valve **A**.
- Unscrew the adjusting dowel lock-nut.
- Using the platform control panel, drive the machine forward and backward and adjust the pressure relief valve by means of the adjusting dowel so as to reach the pressure value indicated in chapter "**Technical Features**". Initially carry out the operation softly to check that the above mentioned valves have been disconnected properly (the machine should not move).
- Once calibration has been carried out, lock the adjusting dowel by means of the lock-nut.

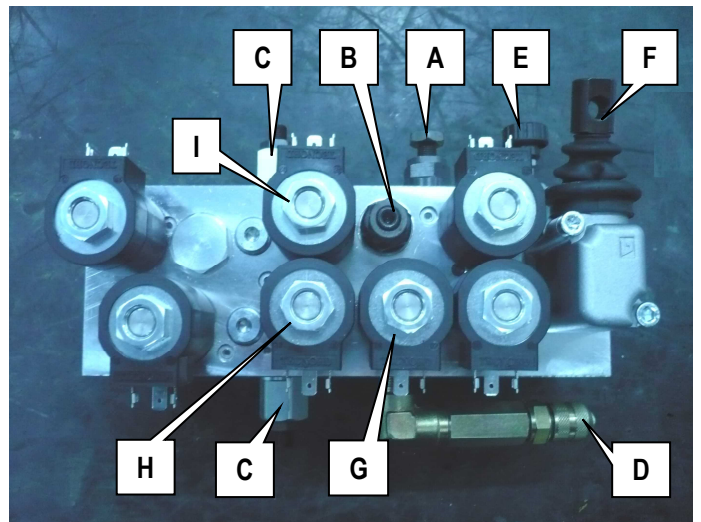
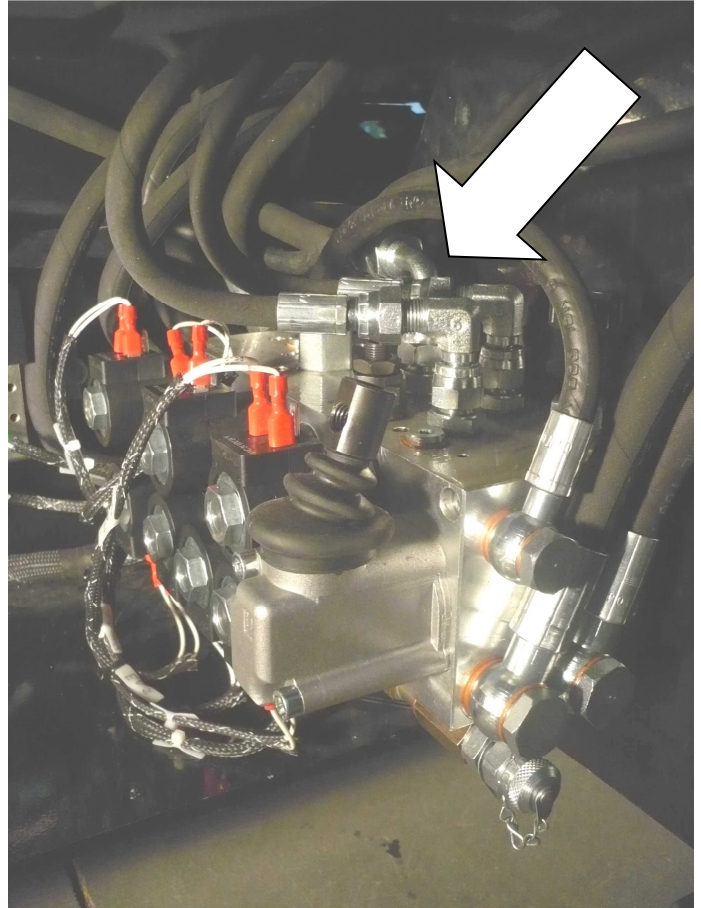

7-8: Hydraulic block



WARNING!
AS THIS OPERATION IS VERY IMPORTANT IT IS TO BE CARRIED OUT BY SPECIALIZED TECHNICIANS ONLY.

7.3.5 Lifting circuit pressure relief valve operation check

The self-propelled aerial platforms, X series, have a pressure relief valve on the lifting circuit to avoid dangerous overpressure values. Normally, this valve does not require any adjustment, since it is calibrated at the factory before the machine is delivered.

The system needs calibration:

- in case of replacement of the hydraulic block
- in case of replacement of the pressure relief valve only.

To check the pressure relief valve on the lifting circuit (figure 7-8):

- Introduce a pressure gauge with full scale of at least 250 bar in the special quick coupling (1/4" BSP) **D**.
- Using the ground control panel lift the machine up to the end stop.
- Check the pressure value. The correct value is indicated in the chapter "**Technical features**".

Check operation at least once a year.

To calibrate the pressure relief valve on the lifting circuit (figure 7-8):

- Introduce a pressure gauge with full scale of at least 250 bar in the special quick coupling (1/4" BSP) **D**.
- Locate the pressure relief valve of lifting circuit **B**.
- Unscrew the adjusting dowel lock-nut.
- Using the ground control panel lift the machine up to the end stop.
- Adjust the pressure relief valve by means of the adjusting dowel so as to reach the pressure value indicated in chapter "**Technical Features**".
- Once calibration has been carried out, lock the adjusting dowel by means of the lock-nut.



WARNING!

AS THIS OPERATION IS VERY IMPORTANT IT IS TO BE CARRIED OUT BY SPECIALIZED TECHNICIANS ONLY.

7.3.6 Braking valves operation check

These valves check the minimum operating pressure during drive (in both running directions) and affect the dynamic braking and the driving speed. Normally, these valves do not require any adjustment, since they are calibrated at the factory before the machine is delivered.

The braking valves stop the machine when the drive controls are released. Once the machine has stopped, the parking brakes automatically come on, thus keeping the machine in position.

Check operation at least once a year.

To check the operation of the braking system:

- With platform completely lowered place the machine on a flat ground, free of obstacles, operate the drive control and when the max. speed is reached, release the control immediately.
- The correct operation of the braking system allows the machine to stop within a distance lower than 70 cm.
- In any case the braking system can stop and keep the machine on slopes as indicated in "**Technical features**" (the braking distance on descents is longer; drive downwards at the min. drive speed).

Calibration of both braking valves is required:

- In case of replacement of the hydraulic unit A.
- If one or both braking valves are to be replaced.

To calibrate the braking valves:

- Locate braking valves **C** (one for each running direction).
- Introduce a pressure gauge with full scale of at least 250 bar in the special quick coupling of hydraulic control unit (1/4" BSP) **D**.
- Using the platform control panel select the minimum drive speed.
- Unscrew the lock-nuts of the adjusting dowels.
- Using the platform control panel drive the machine (in the direction controlled by the valve) on a flat ground in straightforward direction and adjust the braking valve (relevant to that running direction) by means of adjusting dowel so as to achieve the required pressure value (call the nearest Service Centre to ask for the exact value).
- Once the required pressure value has been achieved, check that the valve controlling the braking in the opposite direction has maintained its adjustment.
- Once adjustments are complete (pressure values in the two directions must not vary by more than ± 5 bar), lock the adjusting dowel by means of the lock-nut.



WARNING!

AS THIS OPERATION IS VERY IMPORTANT IT IS TO BE CARRIED OUT BY SPECIALIZED TECHNICIANS ONLY.

7.3.7 Inclinator operation check



WARNING!

Usually the inclinometer does need to be adjusted unless the electronic control unit is replaced. The equipment necessary for the replacement and adjustment of this component is such that these operations should be carried out by skilled personnel.

AS THIS OPERATION IS VERY IMPORTANT IT IS TO BE CARRIED OUT BY SPECIALIZED TECHNICIANS ONLY.

The inclinometer does not require any adjustment since it is calibrated in the factory before the machine is delivered. This device controls the chassis inclination and when inclined over the allowed value:

- It disables lifting.
- It disables drive when platform exceeds a given height (varying according to model).
- It warns the user of the instability condition by means of the audible alarm and platform warning light (see chapter 5).

The inclinometer checks the inclination with respect to the two axes (X;Y); on machine models with the same transversal and longitudinal inclination limits, the control is carried out with reference to one axis only (X-axis).

To check the inclinometer operation according to the **longitudinal axis** (generally **X-axis**):

- Using the controls of the control panel set the machine so as to place a shim of dimension (A+10 mm) under the two rear or front wheels (see following table).
- Wait three seconds (operation delay set at factory) until the danger red light and the platform audible alarm turn on.
- If the alarm is not activated CALL THE TECHNICAL ASSISTANCE.

To check the inclinometer according to the **transversal axis** (normally **Y-axis**):

- Using the controls of the control panel set the machine so as to place a shim of dimension (B+10 mm) under the two side right or left wheels (see following table).
- Wait three seconds (operation delay set at factory) until the danger red light and the platform audible alarm turn on.
- If the alarm is not activated CALL THE TECHNICAL ASSISTANCE.

Check operation at least once a year.

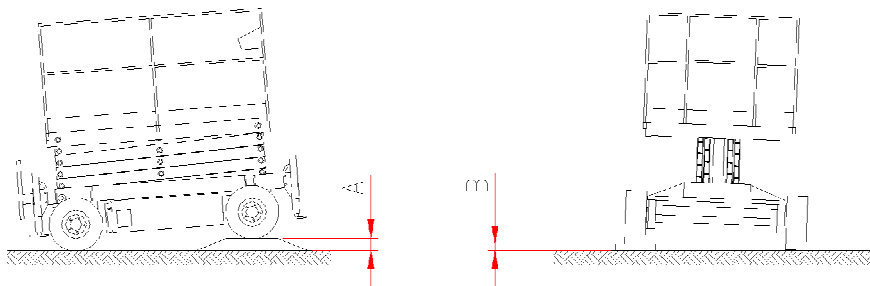

MODELS								
SHIMS	X8EN	X10EW	X10EW WIND	X10EN	X12EW	X12EW WIND	X12EN	X14EW
A [mm]	97	97	97	97	97	97	97	97
B [mm]	26	37	37	26	37	28	16	28



WARNING! The dimensions of shims A and B refer to max. allowed inclination as indicated in table "TECHNICAL FEATURES". To be used during the inclinometer calibration.

7.3.8 Platform overload controller operation check

The AIRO self-propelled aerial platforms, X series, are equipped with a sophisticated platform overload controller.

Normally the overload controller does not require any adjustment, since it is calibrated in the factory before the machine is delivered. This device checks the load on the platform and:

- it disables all movements if the platform is lifted and overloaded by 20% approx. compared to the nominal load
- with platform in transport position and overloaded by 20% compared to the nominal load, it disables lifting only
- it warns the user of the overload condition by means of the platform audible alarm and warning light
- by removing the exceeding load, the machine can be operated again.

The overload controller consists of:

- Deformation transducer (A) (load cell)
- Electronic board (C) for the device calibration located inside the box on the platform

Operation check of the overload controller:

- When platform is completely lowered and with extension deck retracted, load a charge evenly distributed equal to the max. nominal load allowed by the platform (paragraph "Technical features"). In this condition all operations should be possible both from platform and ground control panel.
- With platform completely lowered, add to the nominal load an overload of 20% of the nominal load and carry out the lifting operation. In this condition the red alarm light and the audible alarm turn on.

If the platform is at a height from the ground higher than that indicated in chapter "**Technical features**", the alarm condition locks the machine completely. To operate the machine again, remove the excessive load.

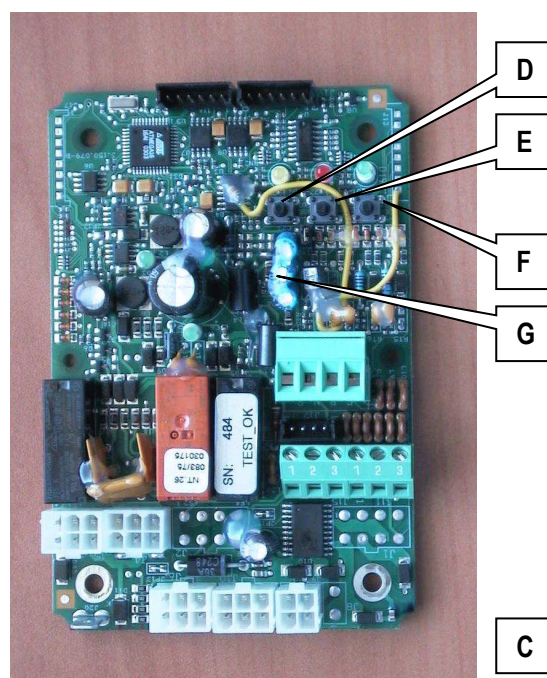

7-9: Overload controller

Check operation at least once a year.

The system needs calibration:

- in case of replacement of one of the items composing the system
- when, following an excessive overload, even after removing the excessive load, the danger condition is reported anyway.

To calibrate the device:

- turn off the machine
- open the box which contains electronic board **C**
- with no load on the platform, introduce the jumper to connector **G**
- turn on the machine
- turn on the machine press button **D** (the yellow and red light turn on)
- press button **E** (the luminosity of the red light increases a few seconds), and the overload controller will be reset
- place a load at the centre of the platform equal to the nominal load + 20%
- press button **F** (the green light turns on a few seconds)
- press button **D** again to exit the calibration procedure (the yellow light turns off and if the procedure has been carried out correctly, the red light stays on signalling the overload)
- turn off the machine
- open the jumper on connector **G**
- turn on the machine
- check that after removing the 20% overload (only the nominal load stays on the platform) the alarm condition does not occur in any of the platform positions (platform lowered, lifted, during drive, with platform extended)
- once the adjustment has been completed, close the box which contains the board.



AS THIS OPERATION IS VERY IMPORTANT IT IS TO BE CARRIED OUT BY SPECIALIZED TECHNICIANS ONLY

7.3.9 Overload controller by-pass

In case of fault and impossibility to calibrate the device, a by-pass of the system is possible in the following way (**FIGURE 7-10**):

- locate connector **A** inside the control unit box
- remove connection
- locate connector **B** (by-pass), usually fixed to connector **A** by means of clamp
- introduce connector **B** instead of connector **A**
- once this operation has been completed, the machine is without overload controller.

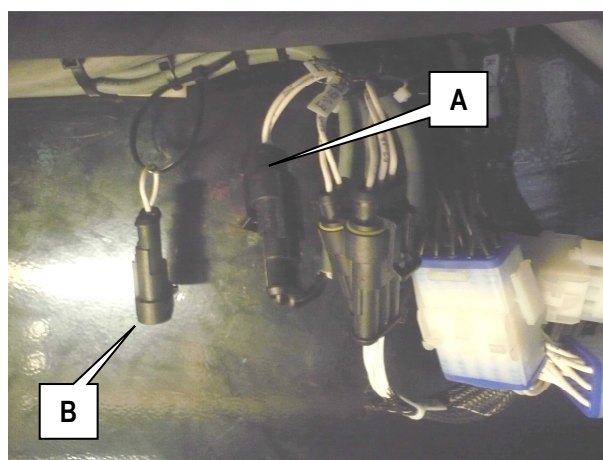

7-10: Overload controller by-pass



WARNING!
THIS OPERATION IS ALLOWED ONLY FOR EMERGENCY HANDLING OF THE MACHINE OR IN THE EVENT OF A FAULT OR IMPOSSIBILITY TO CALIBRATE THE SYSTEM.
DO NOT USE THE MACHINE IF THE OVERLOAD CONTROLLER IS NOT EFFICIENT.

7.3.10 Safety microswitches operation check

All microswitches are to be found on the chassis and platform and can be identified by means of labels.

Microswitch functions:

MPT1 and **MPT2** (figure 7-11):

- control the position of the two pot-hole guards. With one or both microswitches open (guards lifted or not completely lowered) drive is disabled if platform is lifted at a height from the ground indicated in chapter “**Technical Features**” (**M1** activated). Their function is excluded if platform is lowered (**M1** free).

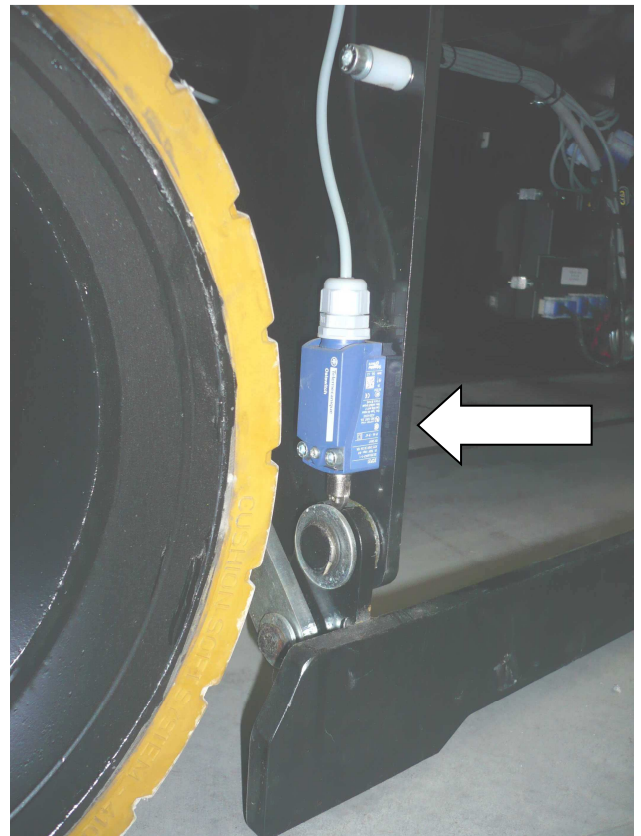

7-11: MPT1 microswitch

M1 (figure 7-12):

- activates drive safety speed with platform at height from the ground indicated in chapter “**Technical features**”.
- stops lowering automatically in a position where the vertical distance between the scissor ends is over 50 mm. In this condition the movement alarm warns about the danger condition by increasing its frequency. The operator on the platform must release the lowering control and wait until the audible alarm stops (about 3 sec.), then he can resume the lowering control.

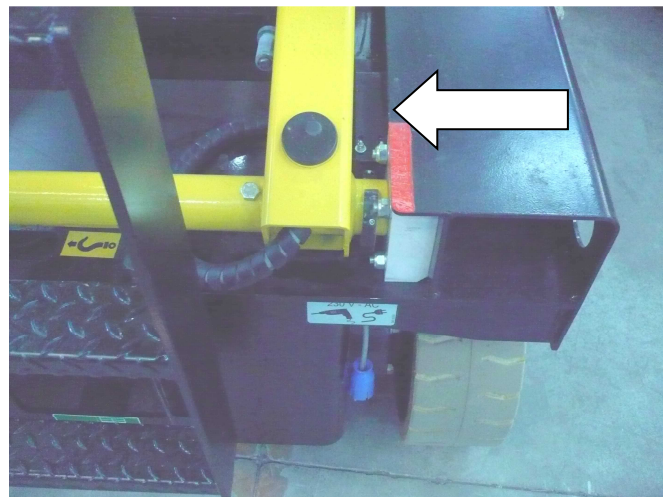

7-12: M1 microswitch

Check operation at least once a year.

7.3.11 Dead-man switch operation check

To check the dead-man switch operation:

- set drive mode with switch **L** (figure 5-1)
- move the joystick control forward and backward in sequence, **WITHOUT PRESSING THE DEAD-MAN SWITCH**
- check that the machine does not perform any movement

- set drive mode with switch **L** (figure 5-1)
- hold down the dead-man switch for more than 10 seconds
- with the switch pressed, move the joystick forward and backward in sequence
- check that the machine does not perform any movement.

If the device works properly, no machine operation is possible from the platform control panel unless you press the dead-man switch beforehand. If this is pressed for more than 10 seconds and no operation is performed, all movements are disabled; to operate the machine again, release the dead-man switch and press it again.

The condition of the switch is indicated by the green led **H** (figure 5-1):

- Green led lit up steady control panel enabled
- Green led lit up flashing control panel disabled

Check operation at least once a year.



WARNING!
IN CASE OF NO OPERATION, CONTACT THE AFTER-SALES SERVICE

7.4 Battery

The battery is one of the most important elements of the machine. It is recommended to keep it in an efficient condition to increase its useful life, to avoid faults and to reduce the management costs of the machine.

7.4.1 General warning instructions

- In case of new batteries do not wait for the flat battery warning before recharging; recharge batteries after 3 or 4 working hours for the first 4/5 times.
- In case of new batteries full performance is achieved after approx. ten cycles of discharge and charge.
- Charge the battery in airy rooms and open the caps to allow the outflow of gas.
- Do not use extension leads exceeding 5 metres to connect the battery charger to the mains.
- Use a cable of suitable section (min 3x2.5 mm²).
- Do not use rolled-up cables.
- Do not approach the battery with flames. Risk of deflagration due to the formation of explosive gases.
- Do not carry out temporary or irregular electric connections.
- The terminals must be tightened and without deposits. The cables must be provided with a good insulation.
- Keep the battery cleaned, dry and free of oxidation products by using antistatic cloths.
- Do not place tools or any other metal object on the battery.
- Check that the electrolyte level is 5-7 mm higher than the splash guard level.
- During charging operations check that the electrolyte temperature is not higher than 45°C max.
- If the machine is equipped with an automatic topping up device, follow the instructions described in the battery user manual carefully.

7.4.2 Battery maintenance

- For normal uses, water topping up is to be carried out every week.
- Top up using distilled or demineralized water.
- Top up after battery charging. After this operation, the electrolyte level must be 5-7 mm higher than the splash guard level.
- For machines equipped with automatic topping up device, follow the instructions given in the battery user manual.
- Battery discharge must be stopped when 80% of the battery rated capacity has been used. An excessive and prolonged discharge irreversibly damages the battery.
- Battery charge is to be carried out according to the instructions given in the next paragraphs.
- Keep caps and connections covered and dry. A careful cleaning allows electric insulation protection, good operation and useful life of the battery.
- In case of faulty operations due to the battery, avoid any direct intervention and call the Customer Service.
- When the machine is not being used the batteries will run down automatically (automatic discharge). To avoid the battery operation from being compromised charge it at least once a month. This has to be done even if the density values of the electrolyte are high.
- To limit automatic battery discharge during periods of inactivity store the machine in environments with temperatures lower than 30°C and remove the main power connector.

7.4.3 Battery recharge



WARNING!

EXPLOSIVE gas is originated during battery charging process. Therefore, charging must take place in airy rooms where no risks of fire and explosion exist and in the presence of fire extinguishers.

Connect the battery charger to the power mains having all protections according to the current standards in force and with the following features:

- Power voltage 230V \pm 10%
- Frequency 50 \div 60 Hz
- Activated grounding line
- Magneto-thermic switch and residual current device ("circuit breaker")

Moreover:

- Do not use extension leads exceeding 5 metres to connect the battery charger to the mains.
- Use a cable of suitable section (min 3x2.5 mm²).
- Do not use rolled-up cables.



IT IS FORBIDDEN

**Connection to mains that do not comply with the above mentioned features.
Failure to comply with the a.m. instructions may cause incorrect functioning of the battery charger with consequent damages not covered by the warranty.**



WARNING!

After charging, when the battery charger is still connected, the electrolyte density values should range from 1.260 g/l to 1.270 g/l (at 25thC).

To use the battery charger follow this procedure:

- connect the battery charger by means of plug **A** to a current socket with the a.m. features.
- check the connection state of the battery charger through led **B**. If it is on, connection has taken place and charging has started. The colour and enable mode of the leds indicate the charging phase (refer to table below).

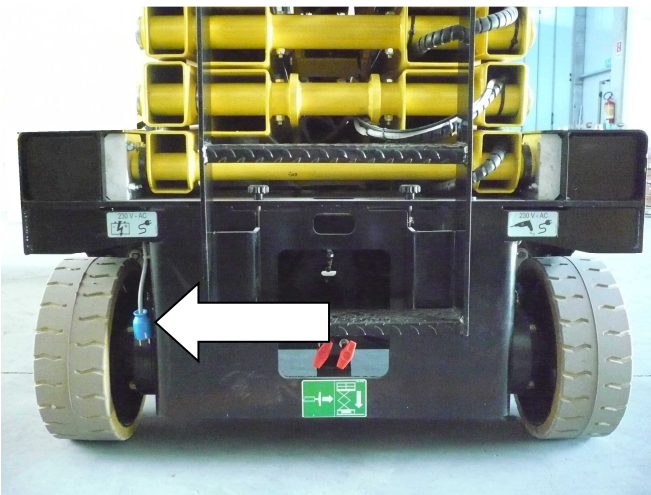

7-13: Battery charger plug

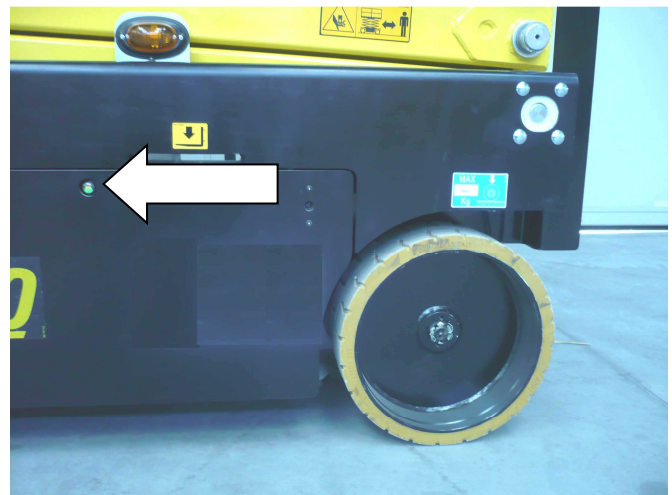

7-14: Battery charger light

WARNING	DESCRIPTION
Red led flashing for a few seconds	Battery charger self-diagnostic phase
Red led on	Indicates the first and second charging phase
Yellow led on	Indicates the equalization of the charging phase
Green led on	Indicates that charging is over; buffer charge active



With the battery charger ON, the machine is automatically off.

To disconnect the battery charger from the power source, disconnect the machine from the electric line.



WARNING!

Before using the machine check that the power cord of the battery charger is disconnected.

7.4.4 Battery charger: fault report

The flashing LED on the battery charger indicator described in the previous paragraph indicates that an alarm situation has occurred:

WARNING	PROBLEM	SOLUTION
Red led constantly flashing	No connection with the battery	Check the connections with the battery
	Connections with the battery inverted	
Red and yellow led blinking	Connection problems	Check all connections
		Check that battery was not disconnected during charging phase
	Battery problems	Check the battery
		Check the fluid level (for pb-acid batteries only)

7.4.5 Battery replacement



Replace the old batteries only with models of the same voltage, capacity, dimensions and mass. Batteries must be approved by the manufacturer.



AS THIS OPERATION IS VERY IMPORTANT IT IS TO BE CARRIED OUT BY SPECIALIZED TECHNICIANS ONLY.

CALL THE TECHNICAL SUPPORT

8. MARKS AND CERTIFICATIONS

The models of self-propelled aerial platform described in this manual were subject to the CE type test according to the Directive 2006/42/EC. The certification was issued by:

<p>I.C.E.P.I Srl Via P. Belizzi, 29/31/33 29100 Piacenza - ITALY</p>	
---	--

Test carrying out is shown by the above plate with CE mark applied on the machine and by the declaration of conformity enclosed in this user manual.

9. PLATES AND STICKERS

STANDARD STICKERS CODES

	CODE	DESCRIPTION	QUANTITY
1	001.10.001	AIRO warnings plate	1
2	001.10.024	AIRO serial number plate	1
3	001.10.031	Towing hook sticker	4
4	001.10.057	General warnings sticker	1
5	001.10.060	Lifting point sticker	4
6	001.10.088	Document holder sticker	1
7	001.10.180	First check sticker	1
8	001.10.243	"Max. Load per wheel" sticker	4
9	010.10.010	Black-yellow line sticker <150X300>	2
10	012.10.007	Sliding platform black-yellow line sticker	2
11	035.10.007	Safety belts coupling sticker	4
12	037.10.007	Machine for indoors universal sticker	1
13	045.10.001	Emergency towing sticker	1
14	045.10.002	Oil level and type sticker	1
15	045.10.003	Hands danger + no stopping sticker	4
16	045.10.005	Battery isolator sticker	1
17	045.10.006	Safety bar sticker	1
18	045.10.011	Battery charger plug sticker	1
19	045.10.013	Symbols manual lowering sticker	1
20	001.10.173	AIRO yellow sticker	2
21	046.10.002	Capacity sticker X8EN X10EN X14EW	1
	047.10.002	Capacity sticker X10EW	1
	047.10.004	Capacity sticker X10EW-WIND	1
	049.10.002	Capacity sticker X12EW	1
	049.10.005	Capacity sticker X12EW-WIND	1
	050.10.004	Capacity sticker X12EN	1
22	048.10.001	Code sticker X8EN	2
	049.10.001	Code sticker X10EW	2
	050.10.001	Code sticker X10EN	2
	051.10.001	Code sticker X12EW	1
	050.10.007	Code sticker X12EN	1
	051.10.005	Code sticker X14EW	1
23*	045.10.011	(Optional) electric line plug sticker	1
24*	001.10.021	(Optional) ground symbol sticker	1
25*	001.10.244	(Optional) entrance bar black-yellow line sticker	1

* optional features

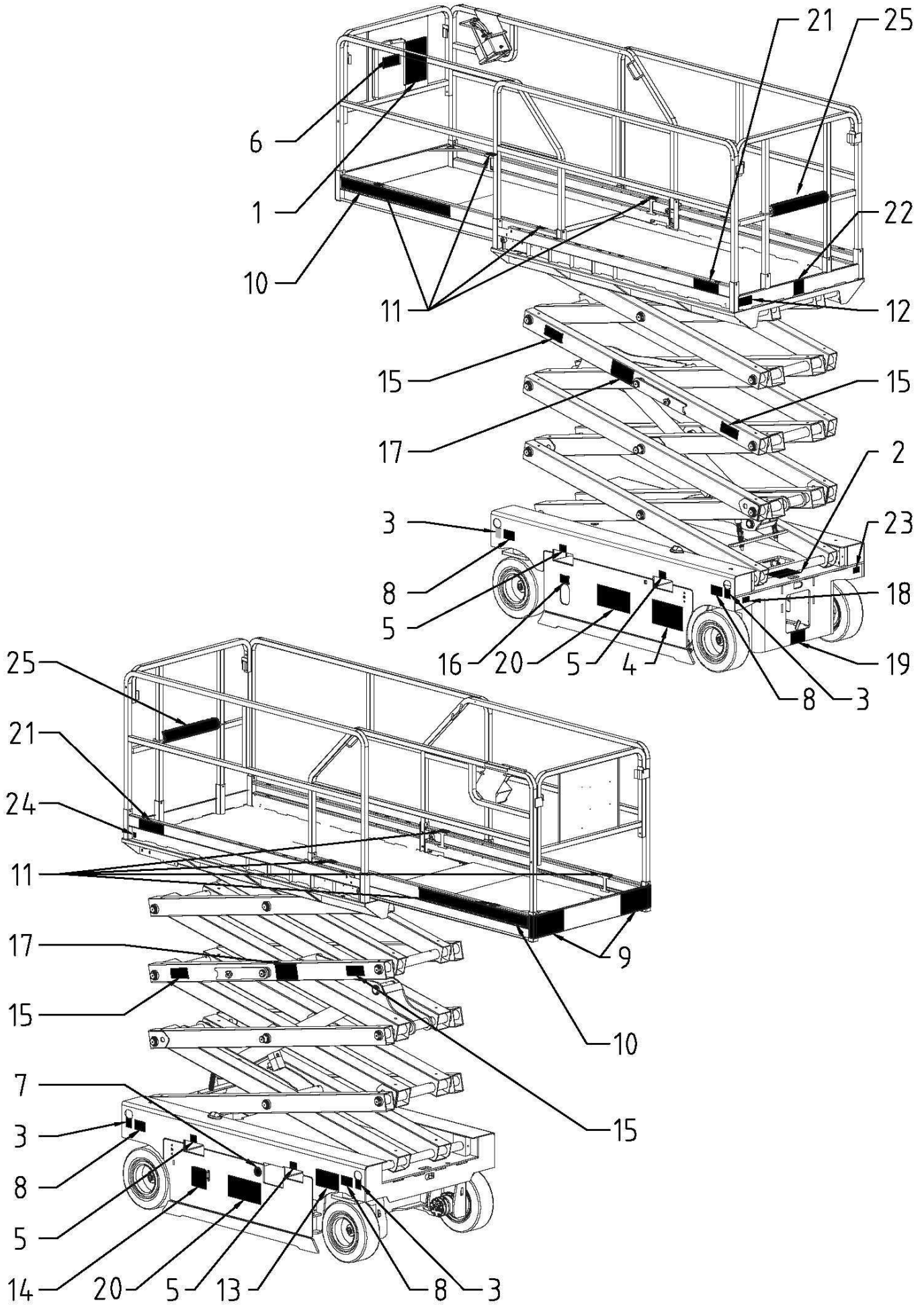

10. CHECK REGISTER

The check register is released to the user of the platform in conformance with Attachment 1 of Directive 2006/42/EC. This register is to be considered an integral part of the equipment and must accompany the machine for its entire life until its final disposal.

The register is provided for the notation, according to the proposed format, of the following events that regard the life of the machine:

- Periodic obligatory inspections under the care of the agency responsible for checking it (in Italy, ASL or ARPA).
- Obligatory periodic inspections to verify the structure, proper machine functioning and the protection and safety systems. Such inspections are the responsibility of the safety manager of the company that owns the machine and must occur with **frequency indicated**.
- Transfers of ownership. In Italy, the purchaser must notify the ISPESL department responsible that the installation of the machine has occurred.
- Extraordinary maintenance work and replacement of important elements of the machine.

REQUIRED PERIODIC INSPECTIONS BY THE OWNER

STRUCTURAL CHECK		DESCRIPTION OF OPERATIONS TO BE PERFORMED	
VISUAL CHECK		Check the integrity of the guard rails; state of the lifting structure; of any access ladders; rust; state of the tyres; oil leaks; locking pins on the structure.	
	DATE	REMARKS	SIGNATURE + STAMP
1st YEAR			
2nd YEAR			
3rd YEAR			
4th YEAR			
5th YEAR			
6th YEAR			
7th YEAR			
8th YEAR			
9th YEAR			
10th YEAR			
DEFORMATION OF TUBES AND CABLES		Most of all, check at junction points that tubes and cables do not show any evident defects. Monthly operation. It is not necessary to indicate its execution every month, but at least every year when the other operations are carried out.	
	DATE	REMARKS	SIGNATURE + STAMP
1st YEAR			
2nd YEAR			
3rd YEAR			
4th YEAR			
5th YEAR			
6th YEAR			
7th YEAR			
8th YEAR			
9th YEAR			
10th YEAR			

REQUIRED PERIODIC INSPECTIONS BY THE OWNER

STRUCTURAL CHECK		DESCRIPTION OF OPERATIONS TO BE PERFORMED	
VARIOUS ADJUSTMENTS		See chapter 7.3.1	
	DATE	REMARKS	SIGNATURE + STAMP
1st YEAR			
2nd YEAR			
3rd YEAR			
4th YEAR			
5th YEAR			
6th YEAR			
7th YEAR			
8th YEAR			
9th YEAR			
10th YEAR			

GREASING		See chapter 7.3.2 Monthly operation. It is not necessary to indicate its execution every month, but at least every year when the other operations are carried out.	
	DATE	REMARKS	SIGNATURE + STAMP
1st YEAR			
2nd YEAR			
3rd YEAR			
4th YEAR			
5th YEAR			
6th YEAR			
7th YEAR			
8th YEAR			
9th YEAR			
10th YEAR			

REQUIRED PERIODIC INSPECTIONS BY THE OWNER

CHECK	DESCRIPTION OF OPERATIONS TO BE PERFORMED		
HYDRAULIC TANK OIL LEVEL CHECK	See chapter 7.3.3 Monthly operation. It is not necessary to indicate its execution every month, but at least every year when the other operations are carried out.		
	DATE	REMARKS	SIGNATURE + STAMP
1st YEAR			
2nd YEAR			
3rd YEAR			
4th YEAR			
5th YEAR			
6th YEAR			
7th YEAR			
8th YEAR			
9th YEAR			
10th YEAR			
CALIBRATION CHECK OF LIFTING CIRCUIT PRESSURE RELIEF VALVE	See chapter 7.3.6		
	DATE	REMARKS	SIGNATURE + STAMP
1st YEAR			
2nd YEAR			
3rd YEAR			
4th YEAR			
5th YEAR			
6th YEAR			
7th YEAR			
8th YEAR			
9th YEAR			
10th YEAR			

REQUIRED PERIODIC INSPECTIONS BY THE OWNER

CHECK		DESCRIPTION OF OPERATIONS TO BE PERFORMED	
CALIBRATION CHECK OF PRESSURE RELIEF VALVE		See chapter 7.3.5	
	DATE	REMARKS	SIGNATURE + STAMP
1st YEAR			
2nd YEAR			
3rd YEAR			
4th YEAR			
5th YEAR			
6th YEAR			
7th YEAR			
8th YEAR			
9th YEAR			
10th YEAR			

BATTERY STATE		See chapter 7.4 Daily operation. It is not necessary to indicate its execution every day, but at least every year when the other operations are carried out.	
	DATE	REMARKS	SIGNATURE + STAMP
1st YEAR			
2nd YEAR			
3rd YEAR			
4th YEAR			
5th YEAR			
6th YEAR			
7th YEAR			
8th YEAR			
9th YEAR			
10th YEAR			

REQUIRED PERIODIC INSPECTIONS BY THE OWNER

CHECK	DESCRIPTION OF OPERATIONS TO BE PERFORMED		
TOTAL OIL REPLACEMENT IN HYDRAULIC TANK (EVERY TWO YEARS)	See chapter 7.3.3		
	DATE	REMARKS	SIGNATURE + STAMP
2nd YEAR			
4th YEAR			
6th YEAR			
8th YEAR			
10th YEAR			
HYDRAULIC FILTER REPLACING (EVERY TWO YEARS)	See chapter 7.3.4.		
	DATE	REMARKS	SIGNATURE + STAMP
2nd YEAR			
4th YEAR			
6th YEAR			
8th YEAR			
10th YEAR			

REQUIRED PERIODIC INSPECTIONS BY THE OWNER

SAFETY SYSTEM CHECK		DESCRIPTION OF OPERATIONS TO BE PERFORMED	
INCLINOMETER OPERATION CHECK		See chapter 7.3.8	
	DATE	REMARKS	SIGNATURE + STAMP
1st YEAR			
2nd YEAR			
3rd YEAR			
4th YEAR			
5th YEAR			
6th YEAR			
7th YEAR			
8th YEAR			
9th YEAR			
10th YEAR			

EFFICIENCY CHECK OF PLATFORM OVERLOAD CONTROLLER		DESCRIPTION OF OPERATIONS TO BE PERFORMED	
EFFICIENCY CHECK OF PLATFORM OVERLOAD CONTROLLER		See chapter 7.3.9	
	DATE	REMARKS	SIGNATURE + STAMP
1st YEAR			
2nd YEAR			
3rd YEAR			
4th YEAR			
5th YEAR			
6th YEAR			
7th YEAR			
8th YEAR			
9th YEAR			
10th YEAR			

REQUIRED PERIODIC INSPECTIONS BY THE OWNER

SAFETY SYSTEM CHECK		DESCRIPTION OF OPERATIONS TO BE PERFORMED	
BRAKING SYSTEM EFFICIENCY CHECK		See chapter 7.3.7	
	DATE	REMARKS	SIGNATURE + STAMP
1st YEAR			
2nd YEAR			
3rd YEAR			
4th YEAR			
5th YEAR			
6th YEAR			
7th YEAR			
8th YEAR			
9th YEAR			
10th YEAR			
OPERATION CHECK MICROSWITCHES: M1, MPT1, MPT2		See chapter 7.3.11	
	DATE	REMARKS	SIGNATURE + STAMP
1st YEAR			
2nd YEAR			
3rd YEAR			
4th YEAR			
5th YEAR			
6th YEAR			
7th YEAR			
8th YEAR			
9th YEAR			
10th YEAR			

REQUIRED PERIODIC INSPECTIONS BY THE OWNER

SAFETY SYSTEM CHECK		DESCRIPTION OF OPERATIONS TO BE PERFORMED	
STICKERS AND PLATES CHECK		See Chapter 9. Check the legibility of the aluminium plate on the platform where the main instructions are summarised; that the capacity stickers are on the platform and that they are legible; that the stickers on the ground and platform control panels are legible.	
	DATE	REMARKS	SIGNATURE + STAMP
1st YEAR			
2nd YEAR			
3rd YEAR			
4th YEAR			
5th YEAR			
6th YEAR			
7th YEAR			
8th YEAR			
9th YEAR			
10th YEAR			
CHECK OF EMERGENCY DEVICES		DESCRIPTION OF OPERATIONS TO BE PERFORMED	
MANUAL EMERGENCY LOWERING CHECK		See chapter 5.6	
	DATE	REMARKS	SIGNATURE + STAMP
1st YEAR			
2nd YEAR			
3rd YEAR			
4th YEAR			
5th YEAR			
6th YEAR			
7th YEAR			
8th YEAR			
9th YEAR			
10th YEAR			

REQUIRED PERIODIC INSPECTIONS BY THE OWNER

SAFETY SYSTEM CHECK	DESCRIPTION OF OPERATIONS TO BE PERFORMED		
DEAD-MAN SYSTEM CHECK	See chapter 7.3.12		
	DATE	REMARKS	SIGNATURE + STAMP
1st YEAR			
2nd YEAR			
3rd YEAR			
4th YEAR			
5th YEAR			
6th YEAR			
7th YEAR			
8th YEAR			
9th YEAR			
10th YEAR			

TRANSFERS OF OWNERSHIP

FIRST OWNER

COMPANY	DATE	MODEL	SERIAL NUMBER	DELIVERY DATE

AIRO – Tigieffe S.r.l.

SUBSEQUENT TRANSFERS OF OWNERSHIP

COMPANY	DATE

We affirm that, as of the date quoted above, the technical, dimensional and functional features of this machine were in conformance with what was originally required and that any changes have been recorded in this Register.

THE SELLER

THE PURCHASER

SUBSEQUENT TRANSFERS OF OWNERSHIP

COMPANY	DATE

We affirm that, as of the date quoted above, the technical, dimensional and functional features of this machine were in conformance with what was originally required and that any changes have been recorded in this Register.

THE SELLER

THE PURCHASER

SUBSEQUENT TRANSFERS OF OWNERSHIP

COMPANY	DATE

We affirm that, as of the date quoted above, the technical, dimensional and functional features of this machine were in conformance with what was originally required and that any changes have been recorded in this Register.

THE SELLER

THE PURCHASER

SUBSEQUENT TRANSFERS OF OWNERSHIP

COMPANY	DATE

We affirm that, as of the date quoted above, the technical, dimensional and functional features of this machine were in conformance with what was originally required and that any changes have been recorded in this Register.

THE SELLER

THE PURCHASER

SUBSEQUENT TRANSFERS OF OWNERSHIP

COMPANY	DATE

We affirm that, as of the date quoted above, the technical, dimensional and functional features of this machine were in conformance with what was originally required and that any changes have been recorded in this Register.

THE SELLER

THE PURCHASER

IMPORTANT BREAKDOWNS

DATE	DESCRIPTION OF BREAKDOWN	SOLUTION

SPARE PARTS USED		DESCRIPTION
CODE	QUANTITY	

SERVICE

SAFETY MANAGER

DATE	DESCRIPTION OF BREAKDOWN	SOLUTION

SPARE PARTS USED		DESCRIPTION
CODE	QUANTITY	

SERVICE

SAFETY MANAGER

IMPORTANT BREAKDOWNS

DATE	DESCRIPTION OF BREAKDOWN	SOLUTION

SPARE PARTS USED		DESCRIPTION
CODE	QUANTITY	

SERVICE

SAFETY MANAGER

DATE	DESCRIPTION OF BREAKDOWN	SOLUTION

SPARE PARTS USED		DESCRIPTION
CODE	QUANTITY	

SERVICE

SAFETY MANAGER

SCHEMA IDRAULICO MACCHINE STANDARD
045.07.001
X8EN – X10EN – X10EW – X10EW-WIND

BR1 / BR2	FRENO DI STAZIONAMENTO
BV1	VALVOLA SBLOCCO FRENI PER TRAINO DI EMERGENZA
CB1 / CB2	VALVOLE DI FRENATURA
CIL1	CILINDRO STERZO
CIL2	CILINDRO SOLLEVAMENTO
CM	ATTACCO RAPIDO MANOMETRO 1/4" BSP
DV1	DIVISORE DI FLUSSO
EM1	MOTORE ELETTRICO
EV10A	ELETTROVALVOLA SERIE-PARALLELO TRAZIONE
EV10B	ELETTROVALVOLA BYPASS DIVISORE DI FLUSSO
EV2	ELETTROVALVOLA TRAZIONE AVANTI
EV3	ELETTROVALVOLA TRAZIONE INDIETRO
EV4	ELETTROVALVOLA SOLLEVAMENTO
EV5	ELETTROVALVOLA DISCESA
EV8	ELETTROVALVOLA STERZO DESTRA
EV9	ELETTROVALVOLA STERZO SINISTRA
F1	FILTRO IN ASPIRAZIONE
F2	RETINA FILTRANTE GRUPPO COMANDI DISCESA
GD1	CENTRALINA IDRAULICA
GD2	GRUPPO INTEGRATO CONTROLLO DISCESA
HM1 / HM2	MOTORE TRAZIONE
NR1	VALVOLA UNIDIREZIONALE LINEA DI DISCESA
P1	POMPA AD INGRANAGGI
PM1	POMPA MANUALE TRAINO DI EMERGENZA
RV1	VALVOLA DI MASSIMA PRESSIONE GENERALE
RV2	VALVOLA DI MASSIMA PRESSIONE CIRCUITO DI SOLLEVAMENTO
SEL1	VALVOLA SELETRICE FRENO
ST1	STROZZATORE LINEA DI STERZO
ST2	STROZZATORE COMPENSAZIONE LINEA DIVISORE
ST3	STROZZATORE FRENI
ST4	STROZZATORE LINEA DI DISCESA
T1	SERBATOIO OLIO CON BOCCAPORTO

HYDRAULIC SYSTEM DIAGRAM STANDARD MACHINES

045.07.001

X8EN – X10EN – X10EW – X10EW-WIND

BR1 / BR2	HYDRAULIC BRAKE
BV1	BRAKE RELEASE HAND-OPERATED VALVE
CB1 / CB2	BRAKING VALVES
CIL1	STEER CYLINDER
CIL2	LIFT CYLINDER
CM	QUICK DISCONNECT NIPPLE 1/4" BSP FOR PRESSURE GAUGE
DV1	FLOW DIVIDER
EM1	ELECTRIC MOTOR
EV10A	QUICK / SLOW TRACTION SPEED MODE SOLENOID VALVE
EV10B	FLOW DIVIDER BYPASS SOLENOID VALVE
EV2	FORWARD DRIVE SOLENOID VALVE
EV3	REVERSE DRIVE SOLENOID VALVE
EV4	PLATFORM LIFT-UP SOLENOID VALVE
EV5	PLATFORM LOWERING SOLENOID VALVE
EV8	STEER-RIGHT SOLENOID VALVE
EV9	STEER-LEFT SOLENOID VALVE
F1	SUCTION FILTER
F2	LIFT CYLINDER MANIFOLD FILTER
GD1	FUNCTION MANIFOLD
GD2	LIFT CYLINDER MANIFOLD
HM1 / HM2	DRIVE MOTOR
NR1	LOWERING CIRCUIT CHECK VALVE
P1	GEAR PUMP
PM1	EMERGENCY HAND PUMP
RV1	MAIN RELIEF VALVE
RV2	LIFT CIRCUIT RELIEF VALVE
SEL1	BRAKES SHUTTLE VALVE
ST1	STEER CIRCUIT ORIFICE
ST2	FLOW DIVIDER ORIFICE
ST3	BRAKES ORIFICE
ST4	LOWERING CIRCUIT ORIFICE
T1	OIL TANK

SCHEMA HYDRAULIQUE DE BASE POUR MACHINES STANDARD

045.07.001

X8EN – X10EN – X10EW – X10EW-WIND

BR1 / BR2	FREIN DE STATIONNEMENT
BV1	VANNE DEBLOCAGE FREINS POUR TRACTION D'URGENCE
CB1 / CB2	VANNES DE FREINAGE
CIL1	VERIN DIRECTION
CIL2	VERIN SOULEVEMENT
CM	ATTELAGE RAPIDE MANOMETRE 1/4" BSP
DV1	DIVISEUR DE FLUX
EM1	MOTEUR ELECTRIQUE
EV10A	ELECTROVANNE SERIE-PARALLELE TRACTION
EV10B	ELECTROVANNE BY-PASS DIVISEUR DE FLUX
EV2	ELECTROVANNE TRACTION AVANT
EV3	ELECTROVANNE TRACTION ARRIERE
EV4	ELECTROVANNE SOULEVEMENT
EV5	ELECTROVANNE DESCENTE
EV8	ELECTROVANNE DIRECTION DROITE
EV9	ELECTROVANNE DIRECTION GAUCHE
F1	FILTRE EN ASPIRATION
F2	GRILLE FILTRANTE GROUPE COMMANDES DESCENTE
GD1	DISTRIBUTEUR HYDRAULIQUE
GD2	GROUPE INTEGRE CONTROLE DESCENTE
HM1 / HM2	MOTEUR TRACTION
NR1	VANNE UNIDIRECTIONNELLE LIGNE DE DESCENTE
P1	POMPE A ENGRENAGES
PM1	POMPE MANUELLE TRACTION D'URGENCE
RV1	VANNE GENERALE DE PRESSION MAXIMUM
RV2	VANNE DE PRESSION MAXIMUM DU CIRCUIT DE SOULEVEMENT
SEL1	VANNE SELECTRICE FREIN
ST1	ETRANGLEUR LIGNE DE DIRECTION
ST2	ETRANGLEUR COMPENSATION LIGNE DIVISEUR
ST3	ETRANGLEUR FREINS
ST4	ETRANGLEUR LIGNE DE DESCENTE
T1	RESERVOIR HUILE AVEC ECOUTILLE

PLAN HYDRAULIKANLAGE STANDARDMASCHINEN
045.07.001
X8EN – X10EN – X10EW – X10EW-WIND

BR1 / BR2	STANDBREMSE
BV1	BREMSENLÖSUNGSVENTIL FÜR NOTSCHLEPPEN
CB1 / CB2	BREMSVENTILE
CIL1	LENKZYLINDER
CIL2	HUBZYLINDER
CM	SCHNELLKUPPLUNG DRUCKMESSER 1/4" BSP
DV1	FLUSSTEILER
EM1	ELEKTROMOTOR
EV10A	REIHEN-PARALLELES ELEKTROVENTIL FAHREN
EV10B	ELEKTROVENTIL UMGEHUNG FLUSSTEILER
EV2	ELEKTROVENTIL VORWÄRTSFAHREN
EV3	ELEKTROVENTIL RÜCKWÄRTSFAHREN
EV4	ELEKTROVENTIL ANHEBUNG
EV5	ELEKTROVENTIL ABSENKUNG
EV8	ELEKTROVENTIL LENKUNG RECHTS
EV9	ELEKTROVENTIL LENKUNG LINKS
F1	SAUGFILTER
F2	FILTERNETZ AGGREGAT ABSENKSTEUERUNGEN
GD1	HYDRAULISCHES STEUERGERÄT
GD2	INTEGRIERTES AGGREGAT ABSENKKONTROLLE
HM1 / HM2	FAHRMOTOR
NR1	SPERRVENTIL ABSENKLEITUNG
P1	ZAHNRADPUMPE
PM1	HANDPUMPE NOTSCHLEPPEN
RV1	ALLGEMEINES ÜBERDRUCKVENTIL
RV2	ÜBERDRUCKVENTIL HUBKREIS
SEL1	WECHSELVENTIL BREMSE
ST1	DROSSELVENTIL LENKLEITUNG
ST2	DROSSELVENTIL AUSGLEICH TEILERLEITUNG
ST3	DROSSELVENTIL BREMSEN
ST4	DROSSELVENTIL ABSENKLEITUNG
T1	ÖLBEHÄLTER MIT LUKE

ESQUEMA IDRÁULICO MÁQUINAS STANDARD
045.07.001
X8EN – X10EN – X10EW – X10EW-WIND

BR1 / BR2	FRENO DE ESTACIONAMIENTO
BV1	VÁLVULA DESBLOQUEO FRENOS PARA REMOLQUE DE EMERGENCIA
CB1 / CB2	VÁLVULAS DE FRENADO
CIL1	CILINDRO DIRECCIÓN
CIL2	CILINDRO ELEVACIÓN
CM	ACOPAMIENTO RÁPIDO MANÓMETRO 1/4" BSP
DV1	DIVISOR DE FLUJO
EM1	MOTOR ELÉCTRICO
EV10A	ELECTROVÁLVULA SERIE – PARALELO TRACCIÓN
EV10B	ELECTROVÁLVULA BYPASS DIVISOR DE FLUJO
EV2	ELECTROVÁLVULA TRACCIÓN ADELANTE
EV3	ELECTROVÁLVULA TRACCIÓN ATRÁS
EV4	ELECTROVÁLVULA SUBIDA
EV5	ELECTROVÁLVULA BAJADA
EV8	ELECTROVÁLVULA VIRAJE A LA DERECHA
EV9	ELECTROVÁLVULA VIRAJE A LA IZQUIERDA
F1	FILTRO DE ASPIRACIÓN
F2	REDECILLA DE FILTRACIÓN GRUPO MANDOS BAJADA
GD1	CENTRAL HIDRÁULICA
GD2	GRUPO INTEGRADO CONTROL BAJADA
HM1 / HM2	MOTOR DE TRACCIÓN
NR1	VÁLVULA UNIDIRECCIONAL LÍNEA DE BAJADA
P1	BOMBA DE ENGRANAJES
PM1	BOMBA MANUAL REMOLQUE DE EMERGENCIA
RV1	VÁLVULA GENERAL DE SEGURIDAD
RV2	VÁLVULA DE SEGURIDAD CIRCUITO DE ELEVACIÓN
SEL1	VÁLVULA SELECTORA FRENO
ST1	ESTRANGULADOR LÍNEA DE DIRECCIÓN
ST2	ESTRANGULADOR COMPENSACIÓN LÍNEA DIVISOR
ST3	ESTRANGULADOR FRENOS
ST4	ESTRANGULADOR LÍNEA DE BAJADA
T1	DEPÓSITO DE ACEITE CON ESCOTILLA

HYDRAULISCH SCHEMA STANDAARD MACHINES
045.07.001
X8EN – X10EN – X10EW – X10EW-WIND

BR1 / BR2	PARKEERREM
BV1	REMONTGRENDKLEP VOOR SLEPEN IN GEVAL VAN NOOD
CB1 / CB2	REMKLEPPEN
CIL1	STUURCILINDER
CIL2	HEFCILINDER
CM	SNELKOPPELING 1/4" BSP VOOR MANOMETER
DV1	STROMINGSVERDELER
EM1	ELEKTROMOTOR
EV10A	ELEKTROMAGNETISCHE KLEP SERIE-PARALLEL RIJDEN
EV10B	ELEKTRISCHE OMLOOPKLEP STROMINGSVERDELER
EV2	ELEKTROMAGNETISCHE KLEP VOORUIT RIJDEN
EV3	ELEKTROMAGNETISCHE KLEP ACHTERUIT RIJDEN
EV4	ELEKTROMAGNETISCHE KLEP HEFFEN
EV5	ELEKTROMAGNETISCHE KLEP DALEN
EV8	ELEKTROMAGNETISCHE KLEP STUURBEWEGING NAAR RECHTS
EV9	ELEKTROMAGNETISCHE KLEP STUURBEWEGING NAAR LINKS
F1	AANZUIGFILTER
F2	FILTERROOSTER BEDIENINGSEENHEID ZAKKEN
GD1	HYDRAULISCHE REGELEENHEID
GD2	GEÏNTEGREERDE EENHEID CONTROLE DAALBEWEGING
HM1 / HM2	RIJMOTOR
NR1	TERUGSLAGKLEP DAALLIJN
P1	TANDWIELPOMP
PM1	HANDPOMP VOOR SLEPEN IN GEVAL VAN NOOD
RV1	HOOFD-MAXIMUM DRUKKLEP
RV2	MAXIMUM DRUKKLEP HEFCIRCUIT
SEL1	REMKEUZEKLEP
ST1	SMOORKLEP STUURLIJN
ST2	SMOORKLEP COMPENSATIE LIJN STROMINGSVERDELER
ST3	SMOORKLEP REMMEN
ST4	SMOORKLEP DAALLIJN
T1	OLIERESERVOIR MET LUIK

ГИДРАВЛИЧЕСКАЯ СХЕМА СТАНДАРТНЫХ МАШИН

045.07.001

X8EN – X10EN – X10EW – X10EW-WIND

BR1 / BR2	СТОЯНОЧНЫЙ ТОРМОЗ
BV1	КЛАПАН РАЗБЛОКИРОВКИ ДЛЯ АВАРИЙНОЙ БУКСИРОВКИ
CB1 / CB2	ТОРМОЗНОЙ КЛАПАН
CIL1	ЦИЛИНДР ПОВОРОТА
CIL2	ЦИЛИНДР ПОДЪЕМА
CM	БЫСТРОРАЗЪЕМНОЕ КРЕПЛЕНИЕ МАНОМЕТРА 1/4" BSP
DV1	ДЕЛИТЕЛЬ ПОТОКА
EM1	ЭЛЕКТРОДВИГАТЕЛЬ
EV10A	ЭЛЕКТРОКЛАПАН ПОСЛЕДОВАТЕЛЬНО-ПАРАЛЛЕЛЬНОГО ДВИЖЕНИЯ
EV10B	ЭЛЕКТРОКЛАПАН BYPASS ДЕЛИТЕЛЬ ПОТОКА
EV2	ЭЛЕКТРОКЛАПАН ТЯГА ВПЕРЕД
EV3	ЭЛЕКТРОКЛАПАН ТЯГА НАЗАД
EV4	ЭЛЕКТРОКЛАПАН ПОДЪЕМА
EV5	ЭЛЕКТРОКЛАПАН СПУСКА
EV8	ЭЛЕКТРОКЛАПАН ПОВОРОТА НАЛЕВО
EV9	ЭЛЕКТРОКЛАПАН ПОВОРОТА НАПРАВО
F1	ВСАСЫВАЮЩИЙ ФИЛЬТР
F2	ФИЛЬТРУЮЩАЯ СЕТКА ГРУППА КОМАНД СПУСКА
GD1	ГИДРАВЛИЧЕСКИЙ РАСПРЕДЕЛИТЕЛЬНЫЙ ЩИТ
GD2	ИНТЕГРИРОВАННАЯ ГРУППА КОНТРОЛЯ СПУСКОМ
NM1 / NM2	ДВИГАТЕЛЬ ТЯГОВОГО ДВИЖЕНИЯ
NR1	ОДНОНАПРАВЛЕННЫЙ КЛАПАН ЛИНИИ СПУСКА
P1	НАСОС В СЦЕПЛЕНИИ
PM1	РУЧНОЙ НАСОС АВАРИЙНОЙ БУКСИРОВКИ
RV1	КЛАПАН ОБЩЕГО МАКСИМАЛЬНОГО ДАВЛЕНИЯ
RV2	КЛАПАН МАКСИМАЛЬНОГО ДАВЛЕНИЯ ПОДЪЕМНОЙ КОНСТРУКЦИИ
SEL1	КЛАПАН ПЕРЕКЛЮЧАТЕЛЯ ТОРМОЗОВ
ST1	ДРОССЕЛЬНЫЙ КЛАПАН ЛИНИИ ПОВОРОТА
ST2	ДРОССЕЛЬНЫЙ КЛАПАН ЛИНИИ ДЕЛИТЕЛЯ
ST3	ДРОССЕЛЬНЫЙ КЛАПАН ТОРМОЗОВ
ST4	ДРОССЕЛЬНЫЙ КЛАПАН ЛИНИИ СПУСКА
T1	МАСЛЯНЫЙ РЕЗЕРВУАР С ОТВЕРСТИЕМ

SCHEMAT HYDRAULICZNY MASZINY STANDARDOWEJ

045.07.001

X8EN – X10EN – X10EW – X10EW-WIND

BR1 / BR2	HAMULEC POSTOJOWY
BV1	ZAWÓR ZWALNIANIA HAMULCÓW DLA HOLOWANIA AWARYJNEGO
CB1 / CB2	ZAWORY HAMOWANIA
CIL1	CYLINDER SKRĘTU
CIL2	CYLINDER PODNOSZENIA
CM	SZYBKOZŁĄCZKA MANOMETRU 1/4" BSP
DV1	PODZIAŁ PRZEPLÝWU
EM1	SILNIK ELEKTRYCZNY
EV10A	ELEKTROZAWÓR SZEREGOWY-RÓWNOLEGŁY TRAKCJI
EV10B	ELEKTROZAWÓR OBEJŚCIA PODZIAŁU PRZEPLÝWU
EV2	ELEKTROZAWÓR TRAKCJI W PRZÓD
EV3	ELEKTROZAWÓR TRAKCJI W TYŁ
EV4	ELEKTROZAWÓR PODNOSZENIA
EV5	ELEKTROZAWÓR OBNIŻANIA
EV8	ELEKTROZAWÓR PRAWEGO SKRĘTU
EV9	ELEKTROZAWÓR LEWEGO SKRĘTU
F1	FILTR SSANIA
F2	SIATKA FILTRUJĄCA ZESPOŁU OBNIŻANIA
GD1	CENTRALKA HYDRAULICZNA
GD2	ZINTEGROWANY ZESPÓŁ KONTROLI OBNIŻANIA
HM1 / HM2	SILNIK TRAKCJI
NR1	ZAWÓR JEDNOKIERUNKOWY LINII OBNIŻANIA
P1	POMPA ZĘBATA
PM1	POMPA RĘCZNA HOLOWANIA AWARYJNEGO
RV1	OGÓLNY ZAWÓR MAKSYMALNEGO CIŚNIENIA
RV2	ZAWÓR MAKSYMALNEGO CIŚNIENIA OBWODU PODNOSZENIA
SEL1	ZAWÓR PRZEŁĄCZNIKA HAMULCA
ST1	URZĄDZENIE ZWĘŻAJĄCE LINIĘ SKRĘTU
ST2	URZĄDZENIE ZWĘŻAJĄCE KOMPENSACJĘ LINII PODZIAŁU
ST3	URZĄDZENIE ZWĘŻAJĄCE HAMULCE
ST4	URZĄDZENIE ZWĘŻAJĄCE LINIĘ OBNIŻANIA
T1	ZBIORNIK OLEJU Z WŁAZEM

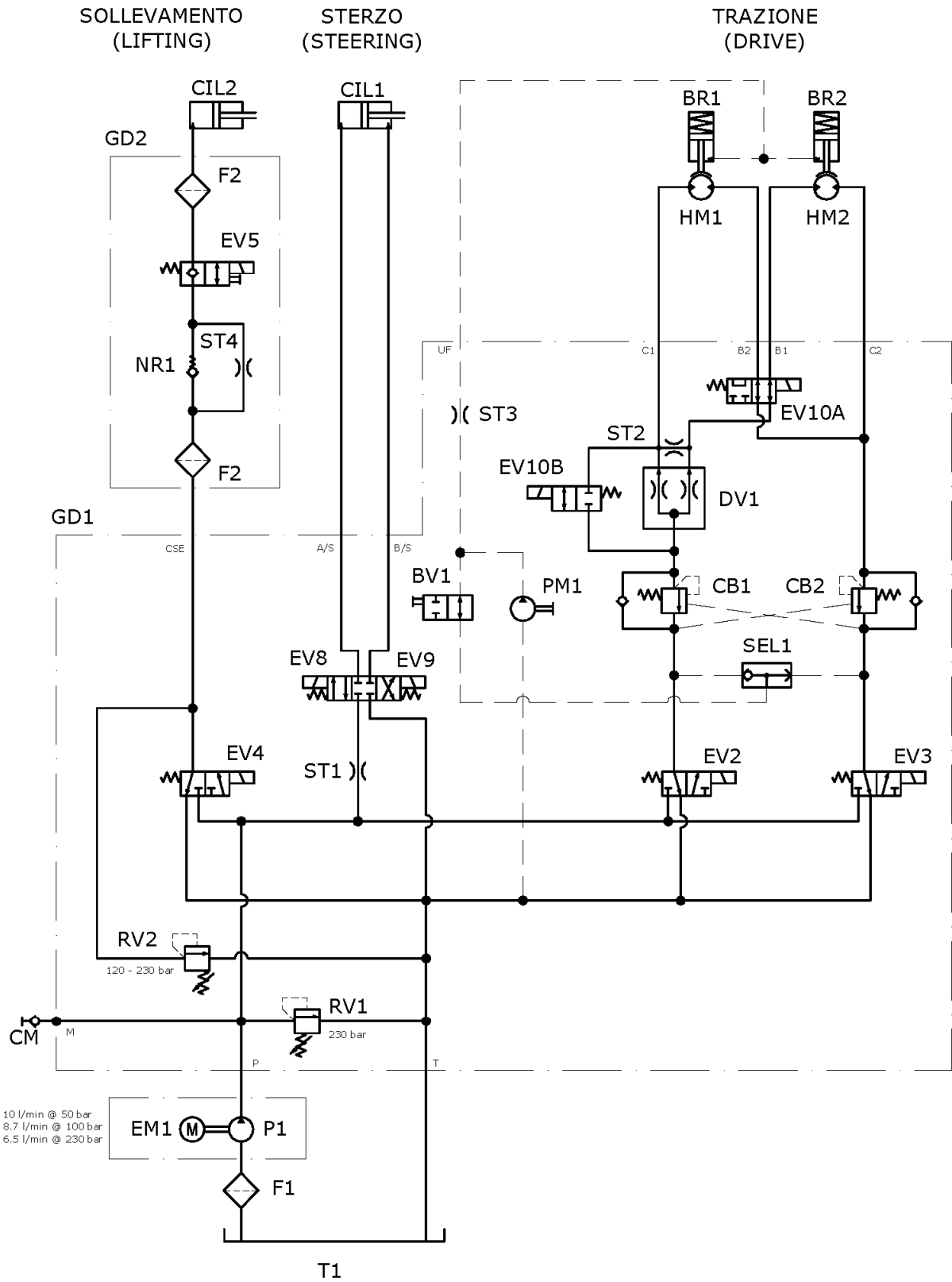

SCHEMA IDRAULICO MACCHINE STANDARD
049.07.001
X12EN – X12EW – X12EW-WIND – X14EW

BR1 / BR2	FRENO DI STAZIONAMENTO
BV1	VALVOLA SBLOCCO FRENI PER TRAINO DI EMERGENZA
CB1 / CB2	VALVOLE DI FRENATURA
CIL1	CILINDRO STERZO
CIL2 / CIL3	CILINDRO SOLLEVAMENTO
CM	ATTACCO RAPIDO MANOMETRO 1/4" BSP
DV1	DIVISORE DI FLUSSO
EM1	MOTORE ELETTRICO
EV10A	ELETTROVALVOLA SERIE-PARALLELO TRAZIONE
EV10B	ELETTROVALVOLA BYPASS DIVISORE DI FLUSSO
EV2	ELETTROVALVOLA TRAZIONE AVANTI
EV3	ELETTROVALVOLA TRAZIONE INDIETRO
EV4	ELETTROVALVOLA SOLLEVAMENTO
EV5A / EV5B	ELETTROVALVOLA DISCESA
EV8	ELETTROVALVOLA STERZO DESTRA
EV9	ELETTROVALVOLA STERZO SINISTRA
F1	FILTRO IN ASPIRAZIONE
F2	RETINA FILTRANTE GRUPPO COMANDI DISCESA
GD1	CENTRALINA IDRAULICA
GD2 / GD3	GRUPPO INTEGRATO CONTROLLO DISCESA
HM1 / HM2	MOTORE TRAZIONE
NR1	VALVOLA UNIDIREZIONALE LINEA DI DISCESA
P1	POMPA AD INGRANAGGI
PM1	POMPA MANUALE TRAINO DI EMERGENZA
RV1	VALVOLA DI MASSIMA PRESSIONE GENERALE
RV2	VALVOLA DI MASSIMA PRESSIONE CIRCUITO DI SOLLEVAMENTO
RV3	VALVOLA DI MASSIMA PRESSIONE CIRCUITO DI DISCESA
SEL1	VALVOLA SELETRICE FRENO
ST1	STROZZATORE LINEA DI STERZO
ST2	STROZZATORE COMPENSAZIONE LINEA DIVISORE
ST3	STROZZATORE FRENI
ST4	STROZZATORE LINEA DI DISCESA
ST5	STROZZATORE LINEA DI DISCESA
T1	SERBATOIO OLIO CON BOCCAPORTO

HYDRAULIC SYSTEM DIAGRAM STANDARD MACHINES
049.07.001
X12EN – X12EW – X12EW-WIND – X14EW

BR1 / BR2	HYDRAULIC BRAKE
BV1	BRAKE RELEASE HAND-OPERATED VALVE
CB1 / CB2	BRAKING VALVES
CIL1	STEER CYLINDER
CIL2 / CIL3	LIFT CYLINDER
CM	QUICK DISCONNECT NIPPLE 1/4" BSP FOR PRESSURE GAUGE
DV1	FLOW DIVIDER
EM1	ELECTRIC MOTOR
EV10A	QUICK / SLOW TRACTION SPEED MODE SOLENOID VALVE
EV10B	FLOW DIVIDER BYPASS SOLENOID VALVE
EV2	FORWARD DRIVE SOLENOID VALVE
EV3	REVERSE DRIVE SOLENOID VALVE
EV4	PLATFORM LIFT-UP SOLENOID VALVE
EV5A / EV5B	PLATFORM LOWERING SOLENOID VALVE
EV8	STEER-RIGHT SOLENOID VALVE
EV9	STEER-LEFT SOLENOID VALVE
F1	SUCTION FILTER
F2	LIFT CYLINDER MANIFOLD FILTER
GD1	FUNCTION MANIFOLD
GD2 / GD3	LIFT CYLINDER MANIFOLD
HM1 / HM2	DRIVE MOTOR
NR1	LOWERING CIRCUIT CHECK VALVE
P1	GEAR PUMP
PM1	EMERGENCY HAND PUMP
RV1	MAIN RELIEF VALVE
RV2	LIFT CIRCUIT RELIEF VALVE
RV3	LOWERING CIRCUIT RELIEF VALVE
SEL1	BRAKES SHUTTLE VALVE
ST1	STEER CIRCUIT ORIFICE
ST2	FLOW DIVIDER ORIFICE
ST3	BRAKES ORIFICE
ST4	LOWERING CIRCUIT ORIFICE
ST5	LOWERING CIRCUIT ORIFICE
T1	OIL TANK

SCHEMA HYDRAULIQUE DE BASE POUR MACHINES STANDARD

049.07.001

X12EN – X12EW – X12EW-WIND – X14EW

BR1 / BR2	FREIN DE STATIONNEMENT
BV1	VANNE DEBLOCAGE FREINS POUR TRACTION D'URGENCE
CB1 / CB2	VANNES DE FREINAGE
CIL1	VERIN DIRECTION
CIL2 / CIL3	VERIN SOULEVEMENT
CM	ATTELAGE RAPIDE MANOMETRE 1/4" BSP
DV1	DIVISEUR DE FLUX
EM1	MOTEUR ELECTRIQUE
EV10A	ELECTROVANNE SERIE-PARALLELE TRACTION
EV10B	ELECTROVANNE BY-PASS DIVISEUR DE FLUX
EV2	ELECTROVANNE TRACTION AVANT
EV3	ELECTROVANNE TRACTION ARRIERE
EV4	ELECTROVANNE SOULEVEMENT
EV5A / EV5B	ELECTROVANNE DESCENTE
EV8	ELECTROVANNE DIRECTION DROITE
EV9	ELECTROVANNE DIRECTION GAUCHE
F1	FILTRE EN ASPIRATION
F2	GRILLE FILTRANTE GROUPE COMMANDES DESCENTE
GD1	DISTRIBUTEUR HYDRAULIQUE
GD2 / GD3	GROUPE INTEGRE CONTROLE DESCENTE
HM1 / HM2	MOTEUR TRACTION
NR1	VANNE UNIDIRECTIONNELLE LIGNE DE DESCENTE
P1	POMPE A ENGRENAGES
PM1	POMPE MANUELLE TRACTION D'URGENCE
RV1	VANNE GENERALE DE PRESSION MAXIMUM
RV2	VANNE DE PRESSION MAXIMUM DU CIRCUIT DE SOULEVEMENT
RV3	VANNE DE PRESSION MAXIMUM DU CIRCUIT DE DESCENTE
SEL1	VANNE SELECTRICE FREIN
ST1	ETRANGLEUR LIGNE DE DIRECTION
ST2	ETRANGLEUR COMPENSATION LIGNE DIVISEUR
ST3	ETRANGLEUR FREINS
ST4	ETRANGLEUR LIGNE DE DESCENTE
ST5	ETRANGLEUR LIGNE DE DESCENTE
T1	RESERVOIR HUILE AVEC ECOUILLE

PLAN HYDRAULIKANLAGE STANDARDMASCHINEN
049.07.001
X12EN – X12EW – X12EW-WIND – X14EW

BR1 / BR2	STANDBREMSE
BV1	BREMSENLÖSUNGSVENTIL FÜR NOTSCHLEPPEN
CB1 / CB2	BREMSVENTILE
CIL1	LENKZYLINDER
CIL2 / CIL3	HUBZYLINDER
CM	SCHNELLKUPPLUNG DRUCKMESSER 1/4" BSP
DV1	FLUSSTEILER
EM1	ELEKTROMOTOR
EV10A	REIHEN-PARALLELES ELEKTROVENTIL FAHREN
EV10B	ELEKTROVENTIL UMGEHUNG FLUSSTEILER
EV2	ELEKTROVENTIL VORWÄRTSFAHREN
EV3	ELEKTROVENTIL RÜCKWÄRTSFAHREN
EV4	ELEKTROVENTIL ANHEBUNG
EV5A / EV5B	ELEKTROVENTIL ABSENKUNG
EV8	ELEKTROVENTIL LENKUNG RECHTS
EV9	ELEKTROVENTIL LENKUNG LINKS
F1	SAUGFILTER
F2	FILTERNETZ AGGREGAT ABSENKSTEUERUNGEN
GD1	HYDRAULISCHES STEUERGERÄT
GD2 / GD3	INTEGRIERTES AGGREGAT ABSENKKONTROLLE
HM1 / HM2	FAHRMOTOR
NR1	SPERRVENTIL ABSENKLEITUNG
P1	ZAHNRADPUMPE
PM1	HANDPUMPE NOTSCHLEPPEN
RV1	ALLGEMEINES ÜBERDRUCKVENTIL
RV2	ÜBERDRUCKVENTIL HUBKREIS
RV3	ÜBERDRUCKVENTIL ABSENKKREIS
SEL1	WECHSELVENTIL BREMSE
ST1	DROSSELVENTIL LENKLEITUNG
ST2	DROSSELVENTIL AUSGLEICH TEILERLEITUNG
ST3	DROSSELVENTIL BREMSEN
ST4	DROSSELVENTIL ABSENKLEITUNG
ST5	DROSSELVENTIL ABSENKLEITUNG
T1	ÖLBEHÄLTER MIT LUKE

ESQUEMA IDRÁULICO MÁQUINAS STANDARD

049.07.001

X12EN – X12EW – X12EW-WIND – X14EW

BR1 / BR2	FRENO DE ESTACIONAMIENTO
BV1	VÁLVULA DESBLOQUEO FRENOS PARA REMOLQUE DE EMERGENCIA
CB1 / CB2	VÁLVULAS DE FRENADO
CIL1	CILINDRO DIRECCIÓN
CIL2 / CIL3	CILINDRO ELEVACIÓN
CM	ACOPLAMIENTO RÁPIDO MANÓMETRO 1/4" BSP
DV1	DIVISOR DE FLUJO
EM1	MOTOR ELÉCTRICO
EV10A	ELECTROVÁLVULA SERIE – PARALELO TRACCIÓN
EV10B	ELECTROVÁLVULA BYPASS DIVISOR DE FLUJO
EV2	ELECTROVÁLVULA TRACCIÓN ADELANTE
EV3	ELECTROVÁLVULA TRACCIÓN ATRÁS
EV4	ELECTROVÁLVULA ELEVACIÓN
EV5A/B	ELECTROVÁLVULA BAJADA
EV8	ELECTROVÁLVULA VIRAJE A LA DERECHA
EV9	ELECTROVÁLVULA VIRAJE A LA IZQUIERDA
F1	FILTRO DE ASPIRACIÓN
F2	REDECILLA DE FILTRACIÓN GRUPO MANDOS BAJADA
GD1	CENTRAL HIDRÁULICA
GD2 / GD3	GRUPO INTEGRADO CONTROL BAJADA
HM1 / HM2	MOTOR DE TRACCIÓN
NR1	VÁLVULA UNIDIRECCIONAL LÍNEA DE BAJADA
P1	BOMBA DE ENGRANAJES
PM1	BOMBA MANUAL REMOLQUE DE EMERGENCIA
RV1	VÁLVULA GENERAL DE SEGURIDAD
RV2	VÁLVULA DE SEGURIDAD CIRCUITO DE ELEVACIÓN
RV3	VÁLVULA DE SEGURIDAD CIRCUITO DE BAJADA
SEL1	VÁLVULA SELECTORA FRENO
ST1	ESTRANGULADOR LÍNEA DE DIRECCIÓN
ST2	ESTRANGULADOR COMPENSACIÓN LÍNEA DIVISOR
ST3	ESTRANGULADOR FRENOS
ST4	ESTRANGULADOR LÍNEA DE BAJADA
ST5	ESTRANGULADOR LÍNEA DE BAJADA
T1	DEPÓSITO DE ACEITE CON ESCOTILLA

HYDRAULISCH SCHEMA STANDAARD MACHINES

049.07.001

X12EN – X12EW – X12EW-WIND – X14EW

BR1 / BR2	PARKEERREM
BV1	REMONTGRENDELKLEP VOOR SLEPEN IN GEVAL VAN NOOD
CB1 / CB2	REMKLEPPEN
CIL1	STUURCILINDER
CIL2 / CIL3	HEFCILINDER
CM	SNELKOPPELING 1/4" BSP VOOR MANOMETER
DV1	STROMINGSVERDELER
EM1	ELEKTROMOTOR
EV10A	ELEKTROMAGNETISCHE KLEP SERIE-PARALLEL RIJDEN
EV10B	ELEKTRISCHE OMLOOPKLEP STROMINGSVERDELER
EV2	ELEKTROMAGNETISCHE KLEP VOORUIT RIJDEN
EV3	ELEKTROMAGNETISCHE KLEP ACHTERUIT RIJDEN
EV4	ELEKTROMAGNETISCHE KLEP HEFFEN
EV5A / EV5B	ELEKTROMAGNETISCHE KLEP DALEN
EV8	ELEKTROMAGNETISCHE KLEP STUURBEWEGING NAAR RECHTS
EV9	ELEKTROMAGNETISCHE KLEP STUURBEWEGING NAAR LINKS
F1	AANZUIGFILTER
F2	FILTERROOSTER BEDIENINGSEENHEID ZAKKEN
GD1	HYDRAULISCHE REGELEENHEID
GD2 / GD3	GEÏNTEGREERDE EENHEID CONTROLE DAALBEWEGING
HM1 / HM2	RIJMOTOR
NR1	TERUGSLAGKLEP DAALLIJN
P1	TANDWIELPOMP
PM1	HANDPOMP VOOR SLEPEN IN GEVAL VAN NOOD
RV1	HOOFD-MAXIMUM DRUKKLEP
RV2	MAXIMUM DRUKKLEP HEFCIRCUIT
RV3	MAXIMUM DRUKKLEP DAALCIRCUIT
SEL1	REMKEUZEKLEP
ST1	SMOORKLEP STUURLIJN
ST2	SMOORKLEP COMPENSATIE LIJN STROMINGSVERDELER
ST3	SMOORKLEP REMMEN
ST4	SMOORKLEP DAALLIJN
ST5	SMOORKLEP DAALLIJN
T1	OLIERESERVOIR MET LUIK

ГИДРАВЛИЧЕСКАЯ СХЕМА СТАНДАРТНЫХ МАШИН

049.07.001

X12EN – X12EW – X12EW-WIND – X14EW

BR1 / BR2	СТОЯНОЧНЫЙ ТОРМОЗ
BV1	КЛАПАН РАЗБЛОКИРОВКИ ДЛЯ АВАРИЙНОЙ БУКСИРОВКИ
CB1 / CB2	ТОРМОЗНОЙ КЛАПАН
CIL1	ЦИЛИНДР ПОВОРОТА
CIL2 / CIL3	ЦИЛИНДР ПОДЪЕМА
CM	БЫСТРОРАЗЪЕМНОЕ КРЕПЛЕНИЕ МАНОМЕТРА 1/4" BSP
DV1	ДЕЛИТЕЛЬ ПОТОКА
EM1	ЭЛЕКТРОДВИГАТЕЛЬ
EV10A	ЭЛЕКТРОКЛАПАН ПОСЛЕДОВАТЕЛЬНО- ПАРАЛЛЕЛЬНОГО ДВИЖЕНИЯ
EV10B	ЭЛЕКТРОКЛАПАН BYPASS ДЕЛИТЕЛЬ ПОТОКА
EV2	ЭЛЕКТРОКЛАПАН ТЯГА ВПЕРЕД
EV3	ЭЛЕКТРОКЛАПАН ТЯГА НАЗАД
EV4	ЭЛЕКТРОКЛАПАН ПОДЪЕМА
EV5A / EV5B	ЭЛЕКТРОКЛАПАН СПУСКА
EV8	ЭЛЕКТРОКЛАПАН ПОВОРОТА НАЛЕВО
EV9	ЭЛЕКТРОКЛАПАН ПОВОРОТА НАПРАВО
F1	ВСАСЫВАЮЩИЙ ФИЛЬТР
F2	ФИЛЬТРУЮЩАЯ СЕТКА ГРУППА КОМАНД СПУСКА
GD1	ГИДРАВЛИЧЕСКИЙ РАСПРЕДЕЛИТЕЛЬНЫЙ ЩИТ
GD2 / GD3	ИНТЕГРИРОВАННАЯ ГРУППА КОНТРОЛЯ СПУСКОМ
NM1 / NM2	ДВИГАТЕЛЬ ТЯГОВОГО ДВИЖЕНИЯ
NR1	ОДНОНАПРАВЛЕННЫЙ КЛАПАН ЛИНИИ СПУСКА
P1	НАСОС В СЦЕПЛЕНИИ
PM1	РУЧНОЙ НАСОС АВАРИЙНОЙ БУКСИРОВКИ
RV1	КЛАПАН ОБЩЕГО МАКСИМАЛЬНОГО ДАВЛЕНИЯ
RV2	КЛАПАН МАКСИМАЛЬНОГО ДАВЛЕНИЯ ПОДЪЕМНОЙ КОНСТРУКЦИИ
RV3	КЛАПАН ПЕРЕКЛЮЧАТЕЛЯ ТОРМОЗОВ
SEL1	ДРОССЕЛЬНЫЙ КЛАПАН ЛИНИИ ПОВОРОТА
ST1	ДРОССЕЛЬНЫЙ КЛАПАН ЛИНИИ ДЕЛИТЕЛЯ
ST2	ДРОССЕЛЬНЫЙ КЛАПАН ТОРМОЗОВ
ST3	ДРОССЕЛЬНЫЙ КЛАПАН ЛИНИИ СПУСКА
ST4	РУЧНОЙ НАСОС АВАРИЙНОЙ БУКСИРОВКИ
ST5	КЛАПАН ОБЩЕГО МАКСИМАЛЬНОГО ДАВЛЕНИЯ
T1	МАСЛЯНЫЙ РЕЗЕРВУАР С ОТВЕРСТИЕМ

SCHEMAT HYDRAULICZNY MASZYN STANDARDOWEJ

049.07.001

X12EN – X12EW – X12EW-WIND – X14EW

BR1 / BR2	HAMULEC POSTOJOWY
BV1	ZAWÓR ZWALNIANIA HAMULCÓW DLA HOLOWANIA AWARYJNEGO
CB1 / CB2	ZAWORY HAMOWANIA
CIL1	CYLINDER KIEROWNICY
CIL2 / CIL3	CYLINDER PODNOSZENIA
CM	SZYBKOZŁĄCZKA MANOMETRU 1/4" BSP
DV1	PODZIAŁ PRZEPŁYWU
EM1	SILNIK ELEKTRYCZNY
EV10A	ELEKTROZAWÓR SZEREGOWY-RÓWNOLEGŁY TRAKCJI
EV10B	ELEKTROZAWÓR OBEJŚCIA PODZIAŁU PRZEPŁYWU
EV2	ELEKTROZAWÓR TRAKCJI W PRZÓD
EV3	ELEKTROZAWÓR TRAKCJI W TYŁ
EV4	ELEKTROZAWÓR PODNOSZENIA
EV5A/B	ELEKTROZAWÓR OBNIŻANIA
EV8	ELEKTROZAWÓR PRAWEGO SKRĘTU
EV9	ELEKTROZAWÓR LEWEGO SKRĘTU
F1	FILTR SSANIA
F2	SIATKA FILTRUJĄCA ZESPOŁU OBNIŻANIA
GD1	CENTRALKA HYDRAULICZNA
GD2 / GD3	ZINTEGROWANY ZESPÓŁ KONTROLI OBNIŻANIA
HM1 / HM2	SILNIK TRAKCJI
NR1	ZAWÓR JEDNOKIERUNKOWY LINII OBNIŻANIA
P1	POMPA ZĘBATA
PM1	POMPA RĘCZNA HOLOWANIA AWARYJNEGO
RV1	OGÓLNY ZAWÓR MAKSYMALNEGO CIŚNIENIA
RV2	ZAWÓR MAKSYMALNEGO CIŚNIENIA OBWODU PODNOSZENIA
RV3	ZAWÓR MAKSYMALNEGO CIŚNIENIA OBWODU OBNIŻANIA
SEL1	ZAWÓR PRZEŁĄCZNIKA HAMULCA
ST1	URZĄDZENIE ZWĘŻAJĄCE LINIĘ KIEROWNICY
ST2	URZĄDZENIE ZWĘŻAJĄCE KOMPENSACJĘ LINII PODZIAŁU
ST3	URZĄDZENIE ZWĘŻAJĄCE HAMULCE
ST4	URZĄDZENIE ZWĘŻAJĄCE LINIĘ OBNIŻANIA
ST5	URZĄDZENIE ZWĘŻAJĄCE LINIĘ OBNIŻANIA
T1	ZBIORNIK OLEJU Z WŁAZEM

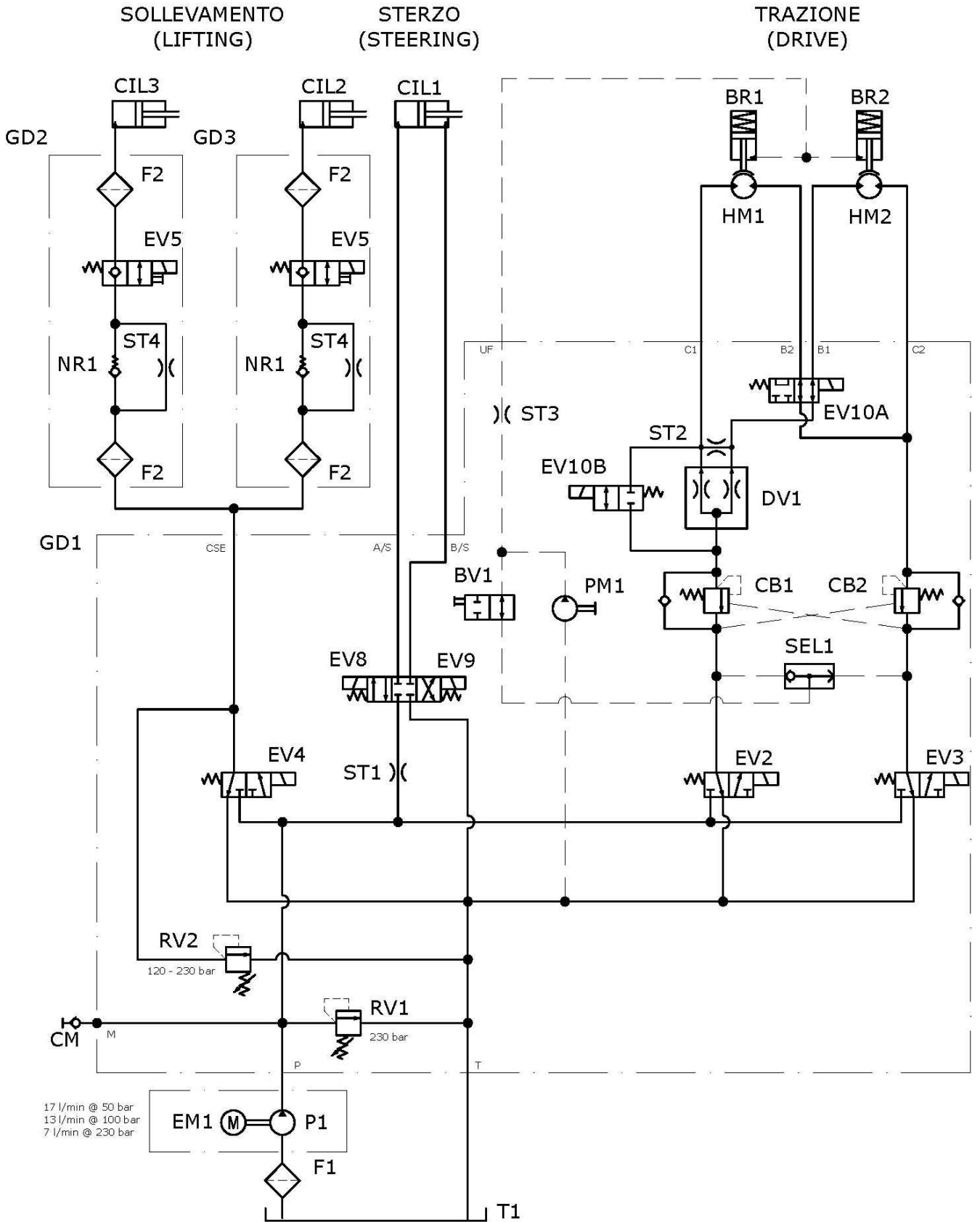

SCHEMA ELETTRICO MACCHINE STANDARD

045.08.011 – 045.08.012

X8EN – X10EW – X10EW-WIND – X10EN – X12EW – X12EW-WIND – X12EN – X14EW

	CONNETTORE P1	P5-11	Comando elettrovalvola EV4 – Salita
P1-1	5V - Positivo potenziometro joystick	P5-12	Comando elettrovalvola EV11 – By pass
P1-2	Segnale potenziometro joystick		
P1-3	-batt- Negativo potenziometro joystick		LEGENDA DISPOSITIVI E GUAINE
P1-5	Led verde consenso comandi in piattaforma	CB	Carica batterie
P1-7	Led rosso allarme generico in piattaforma	CC	Controllo del carico
P1-8	Led rosso allarme sovraccarico in piattaforma	CCT	Cavo comandi a terra
P1-9	AV2 avvisatore acustico in piattaforma	CCP1	Cavo comandi in piattaforma – guaina 1
	CONNETTORE P2	CCP2	Cavo comandi in piattaforma – guaina 2
P2-7	Positivo alimentazione finecorsa + led impianto ON	EV2	Elettrovalvola trazione avanti
P2-8	Comando negativo EV5	EV3	Elettrovalvola trazione indietro
P2-9	Led rosso allarme batteria scarica in piattaforma	EV4	Elettrovalvola di salita
	CONNETTORE P3	EV5 A/B	Elettrovalvola di discesa
P3-1	Positivo comandi in piattaforma	EV8	Elettrovalvola sterzo a sinistra
P3-2	Positivo comandi in piattaforma	EV9	Elettrovalvola sterzo a destra
P3-3	Comando velocità "Lepre"	EV10 A/B	Elettrovalvola trazione veloce
P3-4	Comando Indietro / Discesa	KL	Clacson
P3-5	Comando Avanti / Salita	+KL	Comando positivo clacson
P3-6	Selezione trazione in piattaforma	M1	Finecorsa M1 (Contatto chiuso con piattaforma abbassata)
P3-7	Selezione Salita / Discesa in piattaforma	MPT1	Finecorsa MPT (Contatto chiuso con con pot-hole abbassato)
P3-8	Comando sterzo destra	MPT2	Finecorsa MPT (Contatto chiuso con con pot-hole abbassato)
P3-9	Comando sterzo sinistra	RCB	Relè carica batteria
P3-10	Segnale controllo del carico	SP1	Interruttore di emergenza a terra
P3-12	Comando "uomo presente"	SP2	Interruttore di emergenza in piattaforma
	CONNETTORE P4	TLR	Teleruttore di linea
P4-1	Positivo comandi a terra		
P4-4	Comando discesa da terra	(-)	0V – Negativo batteria
P4-5	Comando salita da terra	-B	0V – Negativo batteria
P4-6	Segnale finecorsa M1 (contatto chiuso con piattaforma abbassata)	5AB	Ponte tra le guaine EV5 e EV8
P4-7	Segnale finecorsa MPT (contatto chiuso con pot-hole abbassati)	+KL	Comando clacson da piattaforma
P4-11	Segnale impianto attivo	MPT	Ponte tra guaine MPT1 e MPT2
P4-12	Segnale batteria scarica	+RCB	+24V – Positivo batteria da relè caricabatteria
	CONNETTORE P5	SP1	Positivo da pulsante di emergenza a terra
P5-1	Comando TLR teleruttore di linea e segnale contaore	SP2	Positivo da pulsante di emergenza in piattaforma
P5-2	Comando elettrovalvola EV2 – Trazione avanti		
P5-3	Comando elettrovalvola EV3 – Trazione indietro	1	Caricabatteria
P5-5	Comando girofari	2	Batteria
P5-6	Comando elettrovalvola EV8 – Sterzo a sinistra	3	Spina disconnessione rapida
P5-7	Comando positivo elettrovalvola EV5 – Discesa	4	Fusibile di potenza
P5-8	Comando elettrovalvola EV9- Sterzo a destra	5	Teleruttore di linea
P5-9	Comando elettrovalvola EV10A / EV10B – Trazione veloce	6	Elettropompa
P5-10	Avvisatore acustico AV1	7	Controller

ELECTRIC DIAGRAM STANDARD MACHINES

045.08.011 – 045.08.012

X8EN – X10EW – X10EW-WIND – X10EN – X12EW – X12EW-WIND – X12EN – X14EW

	P1 CONNECTOR	P5-11	EV4 solenoid valve control – Lifting
P1-1	5V - Positive joystick potentiometer	P5-12	EV11 solenoid valve control – By pass
P1-2	Joystick potentiometer signal		
P1-3	-batt- Negative joystick potentiometer		DEVICES AND SHEATHS KEY
P1-5	Green led platform controls enable	CB	Battery charger
P1-7	Red led platform general alarm	CC	Load control
P1-8	Red led platform overload alarm	CCT	Ground controls cable
P1-9	AV2 platform audible alarm	CCP1	Platform controls cable – sheath 1
	P2 CONNECTOR	CCP2	Platform controls cable – sheath 2
P2-7	Positive limit switch power + system led ON	EV2	Forward drive solenoid valve
P2-8	EV5 negative control	EV3	Backward drive solenoid valve
P2-9	Red led platform flat battery alarm	EV4	Lifting solenoid valve
	P3 CONNECTOR	EV5 A/B	Lowering solenoid valve
P3-1	Positive platform controls	EV8	Left steering solenoid valve
P3-2	Positive platform controls	EV9	Right steering solenoid valve
P3-3	Speed control "Hare"	EV10 A/B	Fast drive solenoid valve
P3-4	Backward / Lowering control	KL	Horn
P3-5	Forward / Lifting control	+KL	Horn positive control
P3-6	Platform drive selection	M1	M1 limit switch (contact closed with platform lowered)
P3-7	Platform Lifting / Lowering selection	MPT1	MPT limit switch (contact closed with pot-hole guard lowered)
P3-8	Right steering control	MPT2	MPT limit switch (contact closed with pot-hole guard lowered)
P3-9	Left steering control	RCB	Battery charger relay
P3-10	Load control signal	SP1	Ground emergency switch
P3-12	"Dead-man" control	SP2	Platform emergency switch
	P4 CONNECTOR	TLR	Line remote switch
P4-1	Positive ground controls		
P4-4	Ground lowering control	(-)	0V – Negative battery
P4-5	Ground lifting control	-B	0V – Negative battery
P4-6	M1 limit switch signal (contact closed with platform lowered)	5AB	Jumper between EV5 and EV8 sheaths
P4-7	MPT limit switch signal (contact closed with pot-hole guards lowered)	+KL	Platform horn control
P4-11	System signal active	MPT	Jumper between MPT1 and MPT2 sheaths
P4-12	Flat battery signal	+RCB	+24V – Positive battery from battery charger relay
	P5 CONNECTOR	SP1	Positive from ground emergency button
P5-1	line remote switch TLR control and hour-meter signal	SP2	Positive from platform emergency button
P5-2	EV2 solenoid valve control – Forward drive		
P5-3	EV3 solenoid valve control – Backward drive	1	Battery charger
P5-5	Rotating beacons control	2	Battery
P5-6	EV8 solenoid valve control – Left steering	3	Quick disconnection plug
P5-7	EV5 solenoid valve positive control - Lowering	4	Power fuse
P5-8	EV9 solenoid valve control – Right steering	5	Line remote switch
P5-9	EV10A / EV10B solenoid valve control – Fast drive	6	Electric pump
P5-10	AVI audible alarm	7	Controller

SCHEMA ELECTRIQUE POUR MACHINES STANDARD

045.08.011 – 045.08.012

X8EN – X10EW – X10EW-WIND – X10EN – X12EW – X12EW-WIND – X12EN – X14EW

	CONNECTEUR P1	P5-11	Commande électrovanne EV4 – Montée
P1-1	5V - Positif potentiomètre manette	P5-12	Commande électrovanne EV11 – By-pass
P1-2	Signal potentiomètre manette		
P1-3	-batt- Négatif potentiomètre manette		LEGENDE DISPOSITIFS ET GAINES
P1-5	Diode verte consentement commandes dans plate-forme	CB	Chargeur de batterie
P1-7	Diode rouge alarme général dans plate-forme	CC	Contrôle de la charge
P1-8	Diode rouge alarme surcharge dans plate-forme	CCT	Câble commandes au sol
P1-9	AV2 avertisseur sonore dans plate-forme	CCP1	Câble commandes dans plate-forme – gaine 1
	CONNECTEUR P2	CCP2	Câble commandes dans plate-forme – gaine 2
P2-7	Positif alimentation fin de course + diode circuit ON	EV2	Electrovanne traction en avant
P2-8	Commande négative EV5	EV3	Electrovanne traction en arrière
P2-9	Diode rouge alarme batterie déchargée dans plate-forme	EV4	Electrovanne de montée
	CONNECTEUR P3	EV5 A/B	Electrovanne de descente
P3-1	Positif commandes dans plate-forme	EV8	Electrovanne braquage à gauche
P3-2	Positif commandes dans plate-forme	EV9	Electrovanne braquage à droite
P3-3	Commande vitesse "Lièvre"	EV10 A/B	Electrovanne traction rapide
P3-4	Commande en arrière / descente	KL	Klaxon
P3-5	Commande en avant / montée	+KL	Commande positive klaxon
P3-6	Sélection traction dans plate-forme	M1	Fin de course M1 (Contact fermé avec plate-forme abaissée)
P3-7	Sélection Montée / Descente dans plate-forme	MPT1	Fin de course MPT (Contact fermé avec pot-hole abaissé)
P3-8	Commande braquage à droite	MPT2	Fin de course MPT (Contact fermé avec pot-hole abaissé)
P3-9	Commande braquage à gauche	RCB	Relais recharge batterie
P3-10	Signal contrôle de la recharge	SP1	Interrupteur d'urgence au sol
P3-12	Commande « homme mort »	SP2	Interrupteur d'urgence dans plate-forme
	CONNECTEUR P4	TLR	Télérupteur de ligne
P4-1	Positif commandes au sol		
P4-4	Commande descente au sol	(-)	0V – Négatif batterie
P4-5	Commande montée du sol	-B	0V – Négatif batterie
P4-6	Signal fin de course M1 (contact fermé avec plate-forme abaissée)	5AB	Pont entre les gaines EV5 et EV8
P4-7	Signal fin de course MPT (contact fermé avec pot-hole abaissés)	+KL	Commande klaxon dans plate-forme
P4-11	Signal circuit actif	MPT	Pont entre les gaines MPT1 et MPT2
P4-12	Signal batterie déchargée	+RCB	+24V – Positif batterie depuis relais chargeur de batterie
	CONNECTEUR P5	SP1	Positif depuis bouton d'urgence au sol
P5-1	Commande TLR télérupteur de ligne et signal compteur	SP2	Positif depuis bouton d'urgence dans plate-forme
P5-2	Commande électrovanne EV2 – Traction en avant		
P5-3	Commande électrovanne EV3 – Traction en arrière	1	Chargeur de batterie
P5-5	Commande gyrophares	2	Batterie
P5-6	Commande électrovanne EV8 – Braquage à gauche	3	Fiche déconnexion rapide
P5-7	Commande positive électrovanne EV5 – Descente	4	Fusible de puissance
P5-8	Commande électrovanne EV9- Braquage à droite	5	Télérupteur de ligne
P5-9	Commande électrovanne EV10A / EV10B – Traction rapide	6	Electropompe
P5-10	Avertisseur sonore AV1	7	Controller

SCHALTPLAN STANDARDMASCHINEN

045.08.011 – 045.08.012

X8EN – X10EW – X10EW-WIND – X10EN – X12EW – X12EW-WIND – X12EN – X14EW

VERBINDER P1		P5-11	Steuerung Elektroventil EV4 – Abhebung
P1-1	5V - Positiv Potentiometer Joystick	P5-12	Steuerung Elektroventil EV11 – Umgehung
P1-2	Signal Potentiometer Joystick		
P1-3	-Batt- Negativ Potentiometer Joystick		ZEICHENERKLÄRUNG VORRICHTUNGEN UND MÄNTEL
P1-5	Grüne LED Freigabe Steuerungen auf der Arbeitsbühne	CB	Ladegerät
P1-7	Rote LED allgemeiner Alarm auf der Arbeitsbühne	CC	Lastkontrolle
P1-8	Rote LED Alarm Überlast auf der Arbeitsbühne	CCT	Kabel Steuerungen am Boden
P1-9	AV2 Akustiksignal auf der Arbeitsbühne	CCP1	Kabel Steuerungen auf der Arbeitsbühne – Mantel 1
VERBINDER P2		CCP2	Kabel Steuerungen auf der Arbeitsbühne – Mantel 2
P2-7	Positiv Versorgung Endschalter + LED Anlage ON	EV2	Elektroventil Vorwärtsfahren
P2-8	Steuerung negativ EV5	EV3	Elektroventil Rückwärtsfahren
P2-9	Rote LED Alarm erschöpfte Batterie auf der Arbeitsbühne	EV4	Elektroventil Anhebung
VERBINDER P3		EV5 A/B	Elektroventil Absenkung
P3-1	Positiv Steuerungen auf der Arbeitsbühne	EV8	Elektroventil Lenkung links
P3-2	Positiv Steuerungen auf der Arbeitsbühne	EV9	Elektroventil Lenkung rechts
P3-3	Steuerung Geschwindigkeit "Hase"	EV10 A/B	Elektroventil schnelles Fahren
P3-4	Steuerung rückwärts / Absenkung	KL	Hupe
P3-5	Steuerung vorwärts / Anhebung	+KL	Steuerung positiv Hupe
P3-6	Einstellung Fahren auf der Arbeitsbühne	M1	Endschalter M1 (geschlossener Kontakt bei abgesenkter Arbeitsbühne)
P3-7	Einstellung Anhebung / Absenkung auf der Arbeitsbühne	MPT1	Endschalter MPT (geschlossener Kontakt bei abgesenktem Schlagloch-Schutzsystem)
P3-8	Steuerung Lenkung rechts	MPT2	Endschalter MPT (geschlossener Kontakt bei abgesenktem Schlagloch-Schutzsystem)
P3-9	Steuerung Lenkung links	RCB	Relais Ladegerät
P3-10	Signal Lastkontrolle	SP1	Not-Aus-Schalter am Boden
P3-12	"Totmann"-Steuerung	SP2	Not-Aus-Schalter auf der Arbeitsbühne
VERBINDER P4		TLR	Leitungsfernschalter
P4-1	Positiv Steuerungen am Boden		
P4-4	Steuerung Absenkung vom Boden aus	(-)	0V – Negativ Batterie
P4-5	Steuerung Anhebung vom Boden aus	-B	0V – Negativ Batterie
P4-6	Signal Endschalter M1 (geschlossener Kontakt bei abgesenkter Arbeitsbühne)	5AB	Brücke zwischen den Mänteln EV5 und EV8
P4-7	Signal Endschalter MPT (geschlossener Kontakt bei abgesenkten Schlagloch-Schutzsystemen)	+KL	Steuerung Hupe an der Arbeitsbühne
P4-11	Signal Anlage aktiv	MPT	Brücke zwischen den Mänteln MPT1 und MPT2
P4-12	Signal Batterie erschöpft	+RCB	+24V – Positiv Batterie vom Relais Ladegerät
VERBINDER P5		SP1	Positiv vom Notauschalter am Boden
P5-1	Steuerung TLR Leitungsfernschalter und Stundenzählersignal	SP2	Positiv vom Not-Aus-Schalter auf der Arbeitsbühne
P5-2	Steuerung Elektroventil EV2 – Vorwärtsfahren		
P5-3	Steuerung Elektroventil EV3 – Rückwärtsfahren	1	Ladegerät
P5-5	Steuerung Rundumleuchten	2	Batterie
P5-6	Steuerung Elektroventil EV8 – Lenkung links	3	Stecker Schnellabtrennung
P5-7	Steuerung positiv Elektroventil EV5 – Absenkung	4	Leistungssicherung
P5-8	Steuerung Elektroventil EV9- Lenkung rechts	5	Leitungsfernschalter
P5-9	Steuerung Elektroventil EV10A / EV10B – schnelles Fahren	6	Elektropumpe
P5-10	Akustiksignal AV1	7	Kontroller

ESQUEMA ELÉCTRICO MÁQUINAS STANDARD

045.08.011 – 045.08.012

X8EN – X10EW – X10EW-WIND – X10EN – X12EW – X12EW-WIND – X12EN – X14EW

	CONECTOR P1		Mando electroválvula EV4 – Subida
P1-1	5V - Positivo potenciómetro joystick	P5-12	Mando electroválvula EV11 – By pass
P1-2	Señal potenciómetro joystick		
P1-3	-bat- Negativo potenciómetro joystick		LEYENDA DISPOSITIVOS Y RECUBRIMIENTOS
P1-5	LED verde consenso mandos en plataforma	CB	Cargador de baterías
P1-7	LED rojo alarma genérica en plataforma	CC	Control de la carga
P1-8	LED rojo alarma sobrecarga en plataforma	CCT	Cable mandos en tierra
P1-9	AV2 avisador acústico en plataforma	CCP1	Cable mandos en plataforma – recubrimiento 1
	CONECTOR P2	CCP2	Cable mandos en plataforma – recubrimiento 2
P2-7	Positivo alimentación final de carrera + LED instalación ON	EV2	Electroválvula tracción adelante
P2-8	Mando negativo EV5	EV3	Electroválvula tracción atrás
P2-9	LED rojo alarma batería descargada en plataforma	EV4	Electroválvula de subida
	CONECTOR P3	EV5 A/B	Electroválvula de bajada
P3-1	Positivo mandos en plataforma	EV8	Electroválvula viraje a la izquierda
P3-2	Positivo mandos en plataforma	EV9	Electroválvula viraje a la derecha
P3-3	Mando velocidad "Liebre"	EV10 A/B	Electroválvula tracción rápida
P3-4	Mando Atrás / Bajada	KL	Bocina eléctrica
P3-5	Mando Adelante / Subida	+KL	Mando positivo bocina eléctrica
P3-6	Selección tracción en plataforma	M1	Final de carrera M1 (contacto cerrado con plataforma bajada)
P3-7	Selección Subida / Bajada en plataforma	MPT1	Final de carrera MPT (contacto cerrado con correderas anti-vuelco bajadas)
P3-8	Mando viraje a la derecha	MPT2	Final de carrera MPT (contacto cerrado con correderas anti-vuelco bajadas)
P3-9	Mando viraje a la izquierda	RCB	Relé carga batería
P3-10	Señal control de la carga	SP1	Interruptor de emergencia en tierra
P3-12	Mando "hombre muerto"	SP2	Interruptor de emergencia en plataforma
	CONECTOR P4	TLR	Telerruptor de línea
P4-1	Positivo mandos en tierra		
P4-4	Mando bajada desde tierra	(-)	0V – Negativo batería
P4-5	Mando subida desde tierra	-B	0V – Negativo batería
P4-6	Señal final de carrera M1 (contacto cerrado con plataforma bajada)	5AB	Puente entre los recubrimientos EV5 y EV8
P4-7	Señal final de carrera MPT (contacto cerrado con correderas anti-vuelco bajadas)	+KL	Mando bocina eléctrica desde plataforma
P4-11	Señal instalación activada	MPT	Puente entre recubrimientos MPT1 y MPT2
P4-12	Señal batería descargada	+RCB	+24V – Positivo batería desde relé cargador de batería
	CONECTOR P5	SP1	Positivo desde pulsador de emergencia en tierra
P5-1	Mando TLR telerruptor de línea y señal cuentahoras	SP2	Positivo desde pulsador de emergencia en plataforma
P5-2	Mando electroválvula EV2 – Tracción adelante		
P5-3	Mando electroválvula EV3 – Tracción atrás	1	Cargador de batería
P5-5	Mando faros giratorios	2	Batería
P5-6	Mando electroválvula EV8 – Viraje a la izquierda	3	Clavija de desconexión rápida
P5-7	Mando positivo electroválvula EV5 – Bajada	4	Fusible de potencia.
P5-8	Mando electroválvula EV9 – Viraje a la derecha	5	Telerruptor de línea
P5-9	Mando electroválvula EV10A / EV10B – Tracción rápida	6	Electrobomba
P5-10	Avisador acústico AV1	7	Controller

ELEKTRISCH SCHEMA STANDAARD MACHINES

045.08.011 – 045.08.012

X8EN – X10EW – X10EW-WIND – X10EN – X12EW – X12EW-WIND – X12EN – X14EW

CONNECTOR P1		P5-11	Bediening elektromagnetische klep EV4 - Heffen
P1-1	5V - Plus potentiometer joystick	P5-12	Bediening elektromagnetische klep EV11 - Overbrugging
P1-2	Signaal potentiometer joystick		
P1-3	-Accu- Min potentiometer joystick		VERKLARING VAN DE TEKENS VAN SYSTEMEN EN KABELMANTELS
P1-5	Groene led vrijgave bedieningen op platform	CB	Acculader
P1-7	Rode led algemeen alarm op platform	CC	Controle van de last
P1-8	Rode led overbelastingalarm op platform	CCT	Kabel bedieningen vanaf de grond
P1-9	AV2 zoemer op platform	CCP1	Kabel bedieningen op platform – kabelmantel 1
CONNECTOR P2		CCP2	Kabel bedieningen op platform – kabelmantel 2
P2-7	Plus stroomvoorziening eindschakelaars + led installatie ON	EV2	Elektromagnetische klep vooruit rijden
P2-8	Bediening min EV5	EV3	Elektromagnetische klep achteruit rijden
P2-9	Rode led alarm accu leeg op platform	EV4	Elektromagnetische klep heffen
CONNECTOR P3		EV5 A/B	Elektromagnetische klep dalen
P3-1	Plus bedieningen op platform	EV8	Elektromagnetische klep stuurbeweging naar links
P3-2	Plus bedieningen op platform	EV9	Elektromagnetische klep stuurbeweging naar rechts
P3-3	Bediening snelheid "Haas"	EV10 A/B	Elektromagnetische klep snel rijden
P3-4	Bediening achteruit / dalen	KL	Claxon
P3-5	Bediening vooruit / heffen	+KL	Bediening plus claxon
P3-6	Keuze rijden op platform	M1	Eindschakelaar M1 (contact gesloten bij omlaag gezet platform)
P3-7	Keuze heffen / dalen op platform	MPT1	Eindschakelaar MPT (contact gesloten bij omlaag gezette pot-holes)
P3-8	Bediening stuurbeweging naar rechts	MPT2	Eindschakelaar MPT (contact gesloten bij omlaag gezette pot-holes)
P3-9	Bediening stuurbeweging naar links	RCB	Relais acculader
P3-10	Signaal lastcontrole	SP1	Noodschakelaar op de grond
P3-12	Dodemansbediening	SP2	Noodschakelaar op platform
CONNECTOR P4		TLR	Lijnafstandsschakelaar
P4-1	Plus bedieningen vanaf de grond		
P4-4	Bediening dalen vanaf de grond	(-)	0V – Min accu
P4-5	Bediening heffen vanaf de grond	-B	0V – Min accu
P4-6	Signaal eindschakelaar M1 (contact gesloten bij omlaag gezet platform)	5AB	Brug tussen kabelmantels EV5 en EV8
P4-7	Signaal eindschakelaar MPT (contact gesloten bij omlaag gezette pot-holes)	+KL	Bediening claxon vanuit platform
P4-11	Signaal installatie actief	MPT	Brug tussen kabelmantels MPT1 en MPT2
P4-12	Signaal accu leeg	+RCB	+24V – Plus accu van relais acculader
CONNECTOR P5		SP1	Plus van noodknop op de grond
P5-1	Bediening TLR lijnafstandsschakelaar en signaal urenteller	SP2	Plus van noodknop op platform
P5-2	Bediening elektromagnetische klep EV2 – Vooruit rijden		
P5-3	Bediening elektromagnetische klep EV3 – Achteruit rijden	1	Acculader
P5-5	Bediening zwaailichten	2	Accu
P5-6	Bediening elektromagnetische klep EV8 – Stuurbeweging naar links	3	Snelonderbrekingsstekker
P5-7	Bediening plus elektromagnetische klep EV5 - Dalen	4	Vermogenszekering
P5-8	Bediening elektromagnetische klep EV9 – Stuurbeweging naar rechts	5	Lijnafstandsschakelaar
P5-9	Bediening elektromagnetische klep EV10A / EV10B – Snel rijden	6	Elektrische pomp
P5-10	Zoemer AV1	7	Besturing

ЭЛЕКТРИЧЕСКАЯ СХЕМА СТАНДАРТНЫХ МАШИН

045.08.011 – 045.08.012

X8EN – X10EW – X10EW-WIND – X10EN – X12EW – X12EW-WIND – X12EN – X14EW

СОЕДИНИТЕЛЬ P1		P5-9	Управление электроклапаном EV10A / EV10B – Быстрая скорость
P1-1	5В – Позитивный потенциометр джойстик	P5-10	Звуковой сигнализатор AV1
P1-2	Сигнал потенциометра джойстик	P5-11	Управление электроклапаном EV4 – Подъем
P1-3	-batt- Негативный потенциометр джойстик	P5-12	Управление электроклапаном EV11 – Ву pass
P1-5	Зеленый индикатор разрешения команд на платформе	ПЕРЕЧЕНЬ УСТРОЙСТВ И КОЖУХОВ	
P1-7	Красный индикатор общей опасности на платформе	CB	Зарядное устройство
P1-8	Красный индикатор опасности перегрузки на платформе	CC	Контроль груза
P1-9	AV2 Звуковой сигнализатор на платформе	CC1	Кабель команд на земле
СОЕДИНИТЕЛЬ P2		CCP1	Кабель команд на платформе – кожух 1
P2-7	Позитивный привод конца хода + индикаторное устройство ON	CCP2	Кабель команд на платформе – кожух 2
P2-8	Негативное управление EV5	EV2	Электроклапан движения вперед
P2-9	Красный индикатор разряженного аккумулятора на платформе	EV3	Электроклапан движения назад
СОЕДИНИТЕЛЬ P3		EV4	Электроклапан подъема
P3-1	Позитивные команды на платформе	EV5 A/B	Электроклапан спуска
P3-2	Позитивные команды на платформе	EV8	Электроклапан поворота налево
P3-3	Команда скорости "Large" («Заяц»)	EV9	Электроклапан поворота направо
P3-4	Команда Назад / Спуск	EV10A/B	Электроклапан быстрой тяги
P3-5	Команда Вперед / Подъем	KL	Клаксон
P3-6	Выбор тягового движения на платформе	+KL	Позитивное управление клаксоном
P3-7	Выбор Подъем / Спуск на платформе	M1	Конец хода M1 (Контакт закрыт с опущенной платформой)
P3-8	Команда поворот направо	MPT1	Конец хода MPT (Контакт закрыт с pot-hole опущенным)
P3-9	Команда поворот налево	MPT2	Конец хода MPT (Контакт закрыт с pot-hole опущенным)
P3-10	Сигнал контроля груза	RCB	Реле зарядного устройства
P3-12	Команда "оператор на месте"	SP1	Аварийный выключатель на земле
СОЕДИНИТЕЛЬ P4		SP2	Аварийный выключатель на платформе
P4-1	Позитивный команды на земле	TLR	Линейное дистанционный выключатель
P4-4	Команда спуск на земле	(-)	0V – Негатив аккумулятора
P4-5	Команда подъем на земле	-B	0V – Негатив аккумулятора
P4-6	Сигнал конца хода M1 (контакт закрыт со спущенной платформой)	5AB	Мостик между кожухами EV5 и EV8
P4-7	Сигнал конца хода MPT ((контакт закрыт с pot-hole опущенными))	+KL	Управление клаксоном на платформе
P4-11	Сигнал активности оборудования	MPT	Мостик между кожухами MPT1 и MPT2
P4-12	Сигнал разряженного аккумулятора	+RCB	+24В – Позитив аккумулятора от реле зарядного устройства
СОЕДИНИТЕЛЬ P5		SP1	Позитив от аварийной кнопки на земле
P5-1	Команда TLR дистанционного выключателя и сигнала счетчика моточасов	SP2	Позитив от аварийной кнопки на платформе
P5-2	Управление электроклапаном EV2 – Движение вперед	1	Зарядное устройство
P5-3	Управление электроклапаном EV3 – Движение назад	2	Аккумулятор
P5-5	Управление проблесковыми маячками	3	Вилка быстрого разъединения
P5-6	Управление электроклапаном EV8 – Поворот налево	4	Плавкий предохранитель мощности
P5-7	Позитивное управление электроклапаном EV5 – Спуск	5	Линейный дистанционный выключатель
P5-8	Управление электроклапаном EV9- Поворот направо	6	Электронасос
		7	Контроллер

SCHEMAT ELEKTRYCZNY MASZYNY STANDARDOWEJ

045.08.011 – 045.08.012

X8EN – X10EW – X10EW-WIND – X10EN – X12EW – X12EW-WIND – X12EN – X14EW

ŁĄCZNIK P1		P5-11	El. sterujący elektrozaw. EV4 – Podnoszenie
P1-1	5V - Dodatni potencjometru joysticka	P5-12	El. sterujący elektrozaw. EV11 – Obejście
P1-2	Sygnał potencjometru joysticka		
P1-3	-bat- Ujemny potencjometru joysticka		LEGENDA URZĄDZEŃ I OSŁON
P1-5	LED zielony zgody el. sterujących w podeście	CB	Ładowarka
P1-7	LED czerwony ogólnego alarmu na podeście	CC	Kontrola ładowania
P1-8	LED czerwony alarmu przeciążenia na podeście	CCT	Kabel uziemienia el. sterujących
P1-9	AV2 sygnalizator dźwiękowy na podeście	CCP1	Kabel el. sterując. na podeście – osłona 1
	ŁĄCZNIK P2	CCP2	Kabel el. sterując. na podeście – osłona 2
P2-7	Dodatni zasilania ogranicznika + LED instalacji ON	EV2	Elektrozawór trakcji w przód
P2-8	Element sterujący ujemny EV5	EV3	Elektrozawór trakcji w tył
P2-9	LED czerwony alarmu rozładowanej baterii na podeście	EV4	Elektrozawór podnoszenia
	ŁĄCZNIK P3	EV5 A/B	Elektrozawór obniżania
P3-1	Dodatni el. sterujących na podeście	EV8	Elektrozawór skrętu w lewo
P3-2	Dodatni el. sterujących na podeście	EV9	Elektrozawór skrętu w prawo
P3-3	Element sterujący prędkości "Szybkiej"	EV10 A/B	Elektrozawór szybkiej trakcji
P3-4	Element sterujący w tył / obniżania	KL	Klakson
P3-5	Element sterujący w przód / podnoszenie	+KL	Element sterujący dodatni klaksonu
P3-6	Wybór trakcji na podeście	M1	Ogranicznik M1 (Styk zamknięty z podestem obniżonym)
P3-7	Wybór podnoszenia / obniżania na podeście	MPT1	Ogranicznik MPT (Styk zamknięty z pot-hole obniżonym)
P3-8	Element sterujący skrętu w prawo	MPT2	Ogranicznik MPT (Styk zamknięty z pot-hole obniżonym)
P3-9	Element sterujący skrętu w lewo	RCB	Przełącznik ładowarki
P3-10	Sygnał kontroli ładowania	SP1	Wyłącznik awaryjny uziemiania
P3-12	Element sterujący "obecności człowieka"	SP2	Wyłącznik awaryjny na podeście
	ŁĄCZNIK P4	TLR	Nadajnik linii
P4-1	Element sterujący dodatni uziemienia		
P4-4	Element sterujący obniżania z ziemi	(-)	0V – Ujemny baterii
P4-5	Element sterujący podnoszenia z ziemi	-B	0V – Ujemny baterii
P4-6	Ogranicznik M1 (styk zamknięty z podestem obniżonym)	5AB	Mostek między osłoną EV5 a EV8
P4-7	Ogranicznik MPT (styk zamknięty z pot-hole obniżonym)	+KL	Element sterujący klaksonu z podestu
P4-11	Sygnał aktywnej instalacji	MPT	Mostek między osłonami MPT1 a MPT2
P4-12	Sygnał rozładowanej baterii	+RCB	+24V – Dodatni baterii z przełącznika ładowarki
	ŁĄCZNIK P5	SP1	Dodatni z przycisku awaryjnego do ziemi
P5-1	Element sterujący TLR nadajnika linii i sygnału łącznika	SP2	Dodatni z przycisku awaryjnego na podeście
P5-2	El. sterujący elektrozaw. EV2 – Trakcja w przód		
P5-3	Element sterujący elektrozaworu EV3 – Trakcja w tył	1	Ładowarka
P5-5	Element sterujący zmiany reflektorów	2	Bateria
P5-6	Element sterujący elektrozaworu EV8 – skręt w lewo	3	Wtyczka szybkiego rozłączenia
P5-7	Element sterujący dodatni elektrozaworu EV5 – Obniżenie	4	Bezpiecznik mocy
P5-8	Element sterujący elektrozaworu EV9 – skręt w prawo	5	Nadajnik linii
P5-9	Element sterujący elektrozaworu EV10A / EV10B – Trakcja szybka	6	Elektropompa
P5-10	Sygnalizator dźwiękowy AV1	7	Kontroler

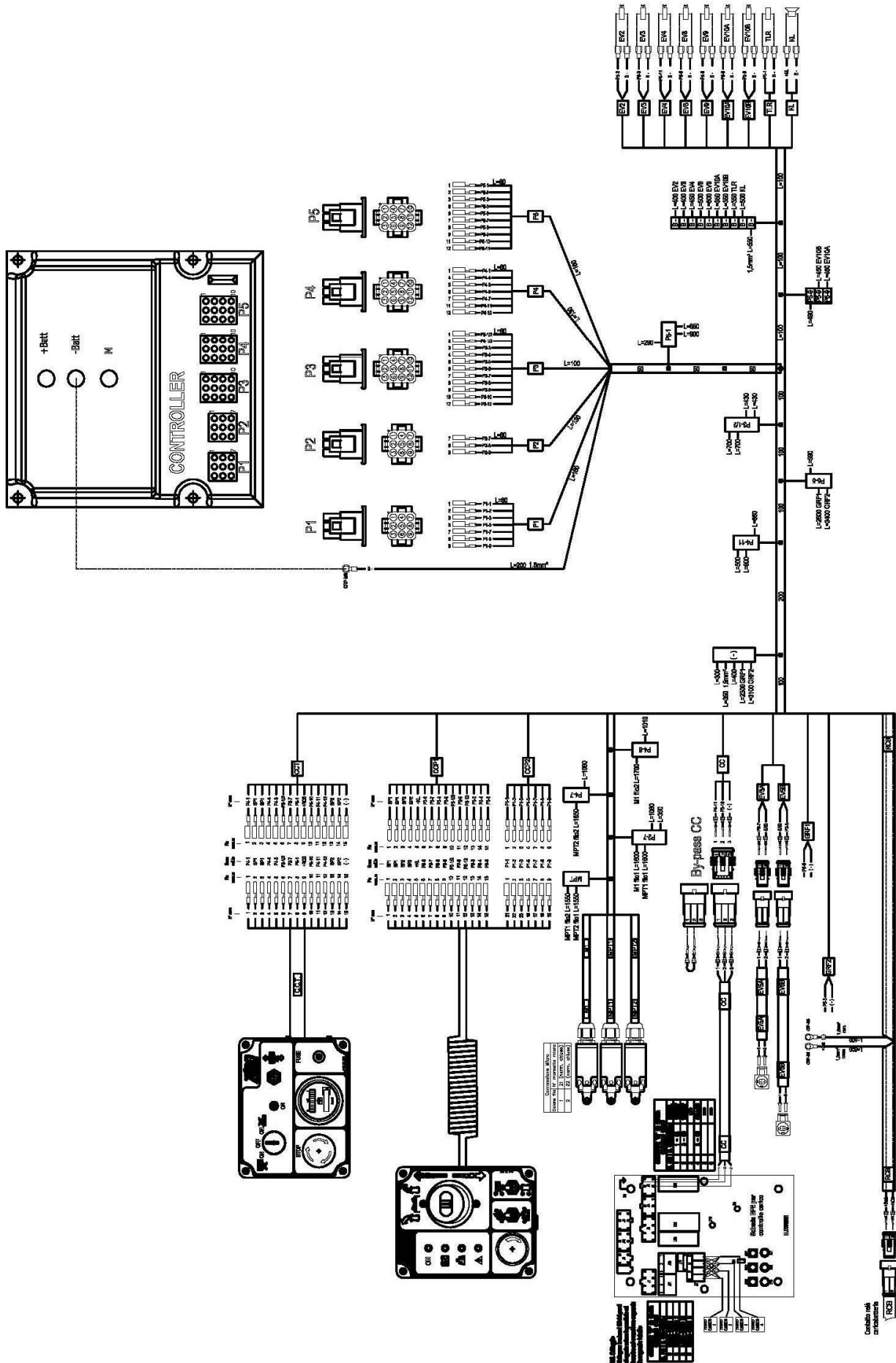

045.08.006
Comandi a terra
Ground control panel

TARATURA CURTIS SU LETTERA "M"
 DISCHARGE ADJUSTMENT SETTING = M

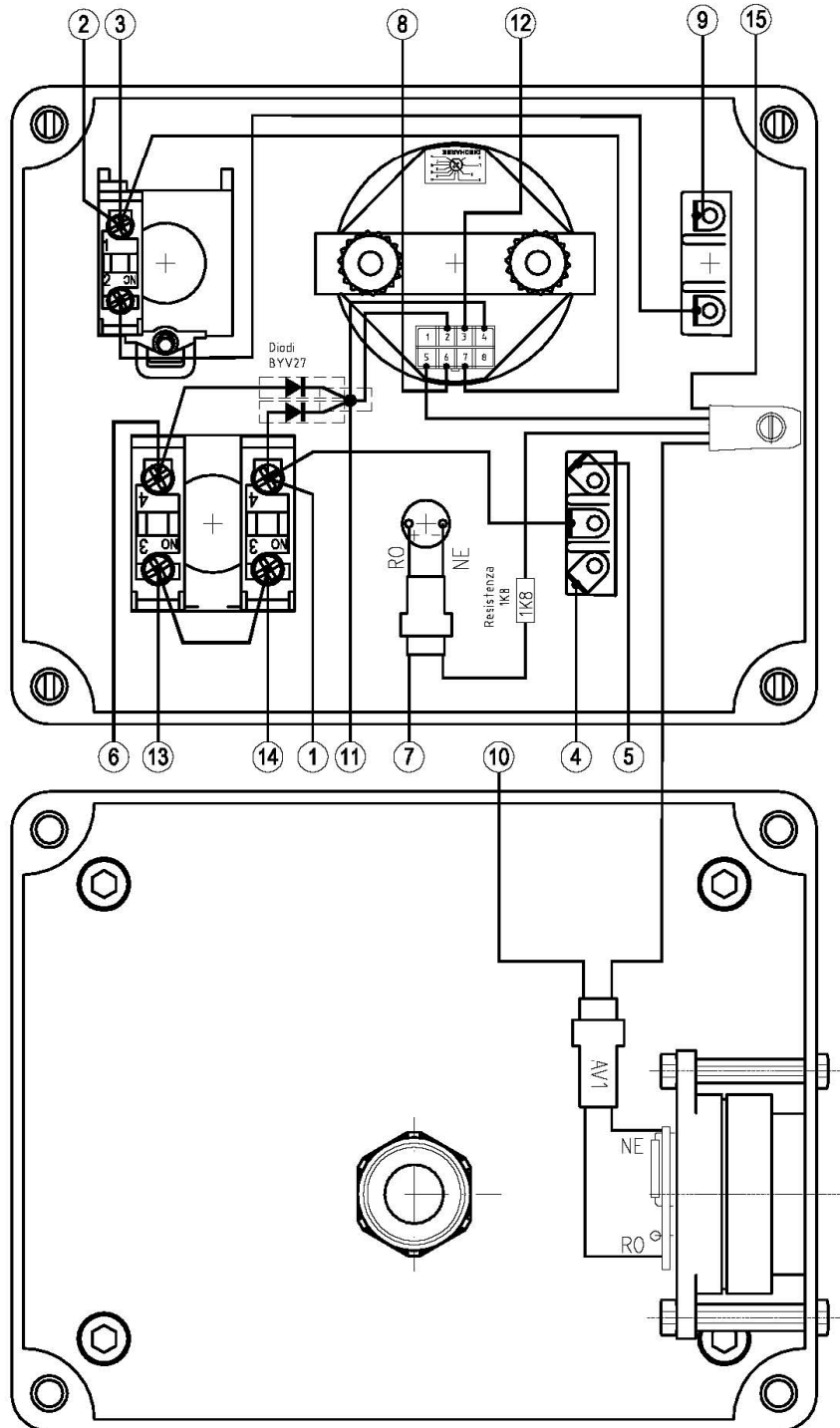

045.08.004

Comandi in piattaforma Platform control panel

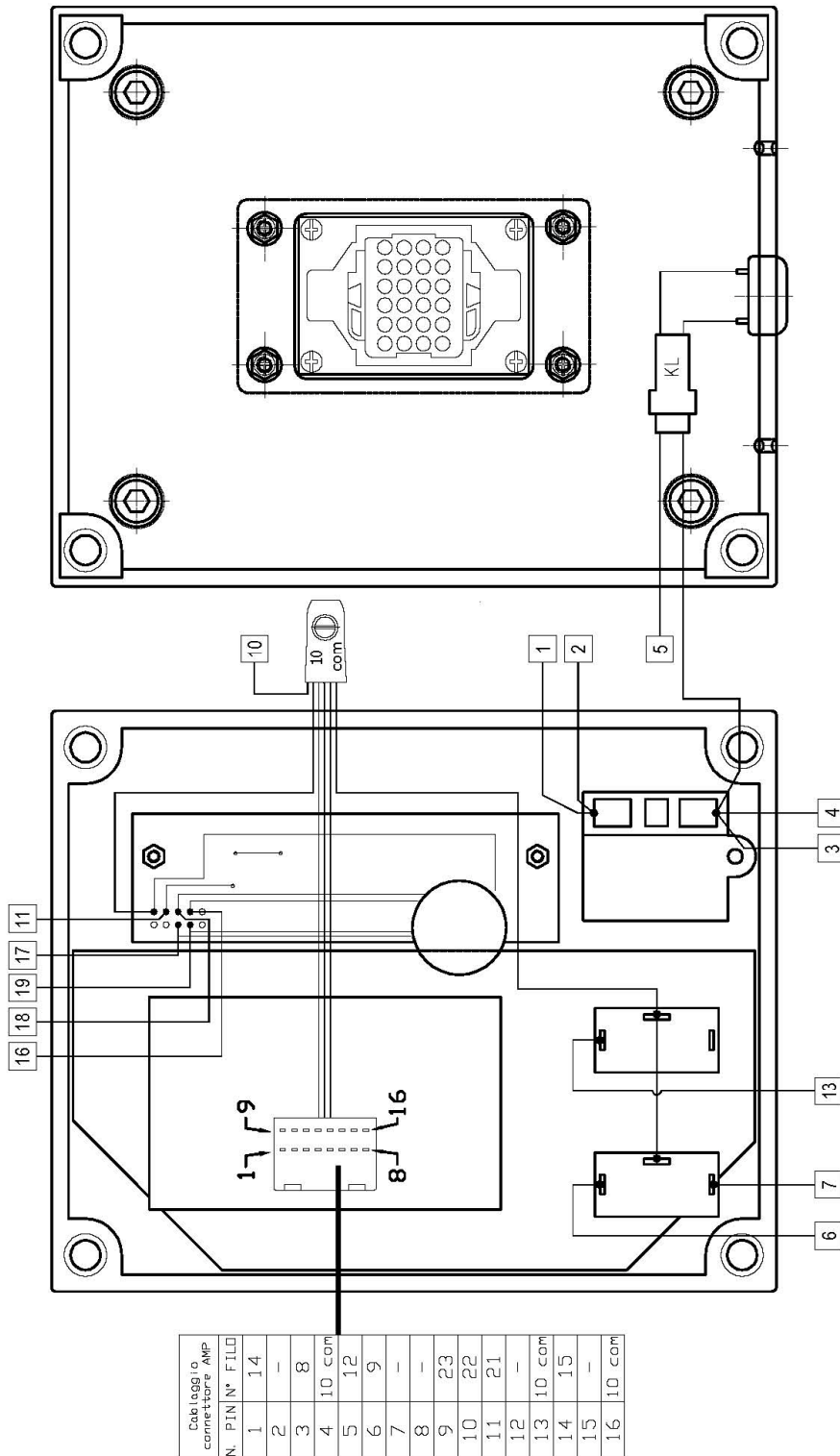

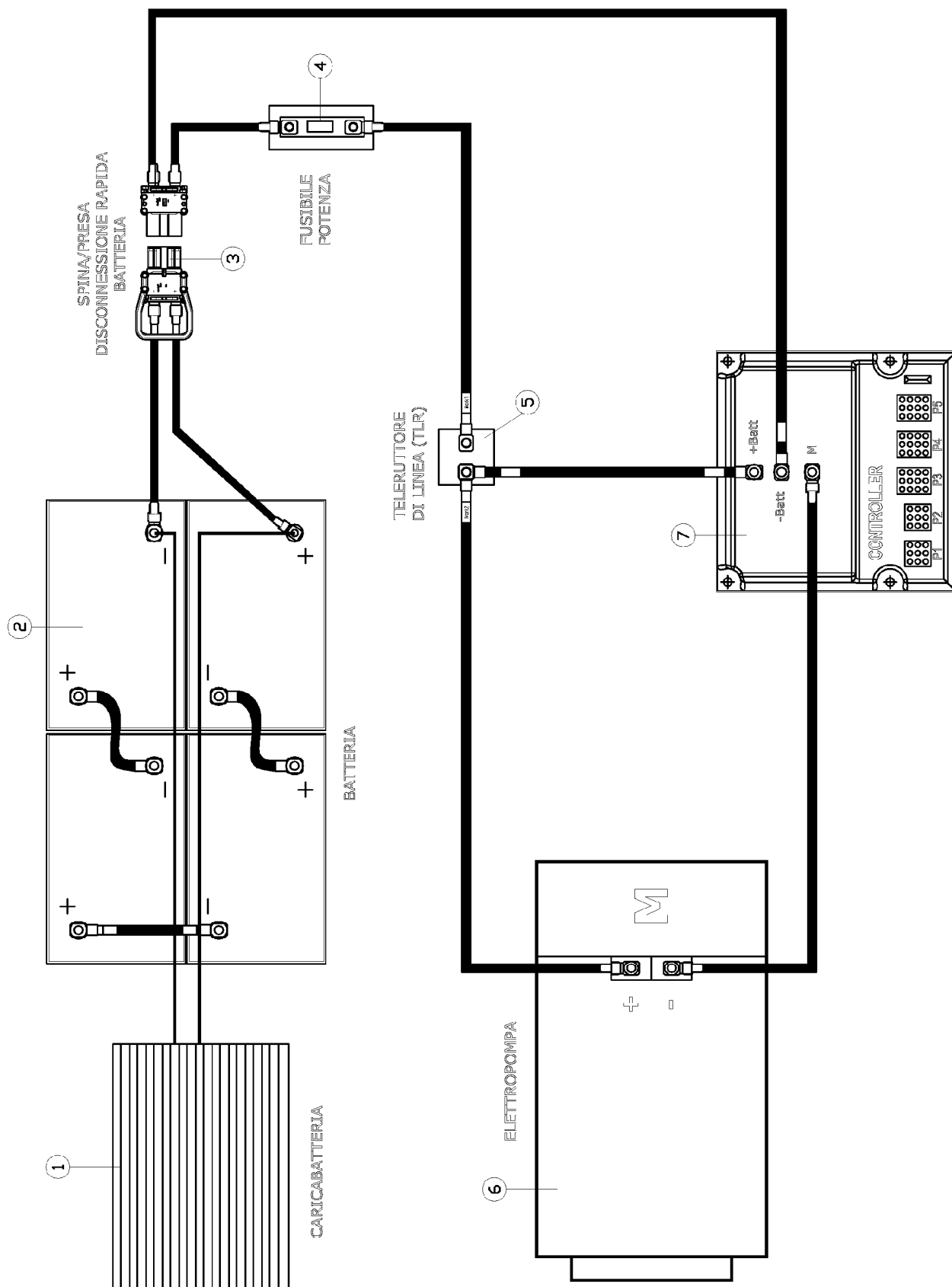



AIRO È UNA DIVISIONE TIGIEFFE SRL - VIA VILLA SUPERIORE, 82 -42045 LUZZARA (RE)

TEL. +39 0522 977365 FAX +39 0522 977015

DICHIARAZIONE CE DI CONFORMITA' - CE DECLARATION OF CONFORMITY - DECLARATION CE DE CONFORMITE' - EG KONFORMITÄTSEKTLÄRUNG - DECLARACION CE DE CONFORMIDAD- ЗАЯВЛЕНИЕ О КОНФОРМНОСТИ ЕС 2006/42/CE

Dichiarazione originale	Original Declaration	Déclaration Originale	Originalerklärung	Declaración Original	Оригинальная декларация
-------------------------	----------------------	-----------------------	-------------------	----------------------	-------------------------

Noi - We - Nous - Wir - Nosotros- мы

Tigieffe s.r.l. - Via Villa Superiore N.° 82 - Luzzara (Reggio Emilia) - ITALIA

Dichiaro sotto la nostra esclusiva responsabilità che il prodotto:	Declare under our exclusive responsibility that the product:	Declarons sous notre responsabilité exclusive que le produit:	Erklären hiermit unter Übernahme der vollen Verantwortung für diese Erklärung, daß das Produkt:	Declaramos bajo nuestra exclusiva responsabilidad que el producto:	Под нашу исключительную ответственность заявляем, что изделие:
--	--	---	---	--	--

Piattaforma di Lavoro Elevabile
Mobile Elevating Work Platform
Plates-forme Elévatrice Mobiles de Personnel
Fahrbare Hubarbeitsbühnen
Plataforma Elevadora Móvil de Personal
Платформа для высотного работ

Modello - Model - Modèle Typ - Modelo-МОДЕЛЬ	N° Chassis - Chassis No. N° Chassis - Fahrgestellnr - N° Chassis - Номер Рама	Anno - Year - Année Baujahr - Ano - Год
X8 EN	XXXXXXXXXX	XXXXXXXXXX

Al quale questa dichiarazione si riferisce è conforme alle direttive 2006/42/CE, 2004/108/CE, e al modello certificato da:	To which this declaration refers is in compliance with the directives 2006/42/CE, 2004/108/CE, and with the model certified by:	Faisant l'objet de la présente déclaration est conforme aux directives 2006/42/CE, 2004/108/CE, et au modèle certifié par	Auf das sich die vorliegende Erklärung bezieht, den 2006/42/CE, 2004/108/CE, Richtlinien und dem von:	Al cual esta declaración se refiere cumple las directivas 2006/42/CE, 2004/108/CE, y el modelo certificado por:	К которой это заявление относится, соответствует директивами 2006/42/CE, 2004/108/CE, и сертифицированной модели из:
--	---	---	---	---	--

ICEPI SPA VIA P. BELIZZI, 29/31/33 29100 PIACENZA (ITALIA)

N. di identificazione 0066

con il seguente numero di certificazione:	with the following certification number:	avec le numéro de certification suivant:	Zertifizierten Modell mit folgender Zertifizierungsnummer:	con el siguiente número de certificación:	со следующим сертифицированным номером:
---	--	--	--	---	---

N.Certificato - Certificate No. - N° du certificat - Bestätigungnummer - N° de certificado - Номер Сертификата

10DM4MA40

e alle norme seguenti:	and with the following standards:	et aux normes suivantes:	die Erklärung entspricht den folgenden Normen:	y a las siguientes normas:	и со следующими нормами:
EN 280 :2001 prEN 280:2009 EN ISO 12100-1:2003 EN ISO 12100-2:2003 EN ISO 60204-1:2006					

Il firmatario di questa dichiarazione di conformità è autorizzato a costituire il Fascicolo Tecnico.	The signatory of this conformity declaration is authorized to set up the Technical File.	Le signataire de cette déclaration de conformité est autorisé à constituer le Dossier Technique.	Der Unterzeichner dieser Konformitätserklärung ist autorisiert, das technische Unterlagen abzufassen.	El firmante de esta declaración de conformidad está autorizado a crear el Expediente Técnico.	Лицо, подписавшее это заявление о соответствии, уполномочено составить техническую документацию оборудования.
--	--	--	---	---	---

Luzzara (RE), data-date-date-Datum-fecha-Дата

.....
Virgilio Ferramola

(Il legale rappresentante - The legal representative)



AIRO È UNA DIVISIONE TIGIEFFE SRL - VIA VILLA SUPERIORE, 82 -42045 LUZZARA (RE)

TEL. +39 0522 977365 FAX +39 0522 977015

DICHIARAZIONE CE DI CONFORMITA' - CE DECLARATION OF CONFORMITY - DECLARATION CE DE CONFORMITE' - EG KONFORMITÄTSEKTLÄRUNG - DECLARACION CE DE CONFORMIDAD- ЗАЯВЛЕНИЕ О КОНФОРМНОСТИ ЕС 2006/42/CE

Dichiarazione originale	Original Declaration	Déclaration Originale	Originalerklärung	Declaración Original	Оригинальная декларация
-------------------------	----------------------	-----------------------	-------------------	----------------------	-------------------------

Noi - We - Nous - Wir - Nosotros- мы

Tigieffe s.r.l. - Via Villa Superiore N.° 82 - Luzzara (Reggio Emilia) - ITALIA

Dichiaro sotto la nostra esclusiva responsabilità che il prodotto:	Declare under our exclusive responsibility that the product:	Declarons sous notre responsabilité exclusive que le produit:	Erklären hiermit unter Übernahme der vollen Verantwortung für diese Erklärung, daß das Produkt:	Declaramos bajo nuestra exclusiva responsabilidad que el producto:	Под нашу исключительную ответственность заявляем, что изделие:
--	--	---	---	--	--

Piattaforma di Lavoro Elevabile
Mobile Elevating Work Platform
Plates-forme Elevatrice Mobiles de Personnel
Fahrbare Hubarbeitsbühnen
Plataforma Elevadora Móvil de Personal
Платформа для высотного работ

Modello - Model - Modèle Typ - Modelo-МОДЕЛЬ	N° Chassis - Chassis No. N° Chassis - Fahrgestellnr - N° Chassis - Номер Рама	Anno - Year - Année Vaujahr - Ano -Год
X10 EN	XXXXXXXXXX	XXXXXXXXXX

Al quale questa dichiarazione si riferisce è conforme alle direttive 2006/42/CE, 2004/108/CE, e al modello certificato da:	To which this declaration refers is in compliance with the directives 2006/42/CE, 2004/108/CE, and with the model certified by:	Faisant l'objet de la présente déclaration est conforme aux directives 2006/42/CE, 2004/108/CE, et au modèle certifié par	Auf das sich die vorliegende Erklärung bezieht, den 2006/42/CE, 2004/108/CE, Richtlinien und dem von:	Al cual esta declaración se refiere cumple las directivas 2006/42/CE, 2004/108/CE, y el modelo certificado por:	К которой это заявление относится, соответствует директивами 2006/42/CE, 2004/108/CE, и сертифицированной модели из:
--	---	---	---	---	--

ICEPI SPA VIA P. BELIZZI, 29/31/33 29100 PIACENZA (ITALIA)

N. di identificazione 0066

con il seguente numero di certificazione:	with the following certification number:	avec le numéro de certification suivant:	Zertifizierten Modell mit folgender Zertifizierungsnummer:	con el siguiente número de certificación:	со следующим сертифицированным номером:
---	--	--	--	---	---

N.Certificato - Certificate No. - N° du certificat - Bestätigungnummer - N° de certificado - Номер Сертификата

10DM4MA41

e alle norme seguenti:	and with the following standards:	et aux normes suivantes:	die Erklärung entspricht den folgenden Normen:	y a las siguientes normas:	и со следующими нормами:
------------------------	-----------------------------------	--------------------------	--	----------------------------	--------------------------

EN 280 :2001 prEN 280:2009 EN ISO 12100-1:2003 EN ISO 12100-2:2003 EN ISO 60204-1:2006

Il firmatario di questa dichiarazione di conformità è autorizzato a costituire il Fascicolo Tecnico.	The signatory of this conformity declaration is authorized to set up the Technical File.	Le signataire de cette déclaration de conformité est autorisé à constituer le Dossier Technique.	Der Unterzeichner dieser Konformitätserklärung ist autorisiert, das technische Unterlagen abzufassen.	El firmante de esta declaración de conformidad está autorizado a crear el Expediente Técnico.	Лицо, подписавшее это заявление о соответствии, уполномочено составить техническую документацию оборудования.
--	--	--	---	---	---

Luzzara (RE), data-date-date-Datum-fecha-Дата

.....
Virginio Ferramola

(Il legale rappresentante - The legal representative)



AIRO È UNA DIVISIONE TIGIEFFE SRL - VIA VILLA SUPERIORE, 82 -42045 LUZZARA (RE)

TEL. +39 0522 977365 FAX +39 0522 977015

DICHIARAZIONE CE DI CONFORMITÀ - CE DECLARATION OF CONFORMITY - DECLARATION CE DE CONFORMITE' - EG KONFORMITÄTSEKTLÄRUNG - DECLARACION CE DE CONFORMIDAD- ЗАЯВЛЕНИЕ О КОНФОРМНОСТИ ЕС 2006/42/CE

Dichiarazione originale	Original Declaration	Déclaration Originale	Originalerklärung	Declaración Original	Оригинальная декларация
-------------------------	----------------------	-----------------------	-------------------	----------------------	-------------------------

Noi - We - Nous - Wir - Nosotros - мы

Tigieffe s.r.l. - Via Villa Superiore N.° 82 - Luzzara (Reggio Emilia) - ITALIA

Dichiaro sotto la nostra esclusiva responsabilità che il prodotto:	Declare under our exclusive responsibility that the product:	Declarons sous notre responsabilité exclusive que le produit:	Erklären hiermit unter Übernahme der vollen Verantwortung für diese Erklärung, daß das Produkt:	Declaramos bajo nuestra exclusiva responsabilidad que el producto:	Под нашу исключительную ответственность заявляем, что изделие:
--	--	---	---	--	--

Piattaforma di Lavoro Elevabile
Mobile Elevating Work Platform
Plates-forme Elévatrice Mobiles de Personnel
Fahrbare Hubarbeitsbühnen
Plataforma Elevadora Móvil de Personal
Платформа для высотного работ

Modello - Model - Modèle Typ - Modelo-МОДЕЛЬ	N° Chassis - Chassis No. N° Chassis - Fahrgestellnr - N° Chassis - Номер Рама	Anno - Year - Année Baujahr - Ano - Год
X10 EW	XXXXXXXXXX	XXXXXXXXXX

Al quale questa dichiarazione si riferisce è conforme alle direttive 2006/42/CE, 2004/108/CE, e al modello certificato da:	To which this declaration refers is in compliance with the directives 2006/42/CE, 2004/108/CE, and with the model certified by:	Faisant l'objet de la présente déclaration est conforme aux directives 2006/42/CE, 2004/108/CE, et au modèle certifié par	Auf das sich die vorliegende Erklärung bezieht, den 2006/42/CE, 2004/108/CE, Richtlinien und dem von:	Al cual esta declaración se refiere cumple las directivas 2006/42/CE, 2004/108/CE, y el modelo certificado por:	К которой это заявление относится, соответствует директивами 2006/42/CE, 2004/108/CE, и сертифицированной модели из:
--	---	---	---	---	--

ICEPI SPA VIA P. BELIZZI, 29/31/33 29100 PIACENZA (ITALIA)

N. di identificazione 0066

con il seguente numero di certificazione:	with the following certification number:	avec le numéro de certification suivant:	Zertifizierten Modell mit folgender Zertifizierungsnummer:	con el siguiente número de certificación:	со следующим сертифицированным номером:
---	--	--	--	---	---

N.Certificato - Certificate No. - N° du certificat - Bestätigungnummer - N° de certificado - Номер Сертификата

10DM4MA42

e alle norme seguenti:	and with the following standards:	et aux normes suivantes:	die Erklärung entspricht den folgenden Normen:	y a las siguientes normas:	и со следующими нормами:
EN 280 :2001 prEN 280:2009 EN ISO 12100-1:2003 EN ISO 12100-2:2003 EN ISO 60204-1:2006					

Il firmatario di questa dichiarazione di conformità è autorizzato a costituire il Fascicolo Tecnico.	The signatory of this conformity declaration is authorized to set up the Technical File.	Le signataire de cette déclaration de conformité est autorisé à constituer le Dossier Technique.	Der Unterzeichner dieser Konformitätserklärung ist autorisiert, das technische Unterlagen abzufassen.	El firmante de esta declaración de conformidad está autorizado a crear el Expediente Técnico.	Лицо, подписавшее это заявление о соответствии, уполномочено составить техническую документацию оборудования.
--	--	--	---	---	---

Luzzara (RE), data-date-date-Datum-fecha-Дата

.....
Virginio Ferramola

(Il legale rappresentante - The legal representative)



AIRO È UNA DIVISIONE TIGIEFFE SRL - VIA VILLA SUPERIORE, 82 -42045 LUZZARA (RE)

TEL. +39 0522 977365 FAX +39 0522 977015

DICHIARAZIONE CE DI CONFORMITA' - CE DECLARATION OF CONFORMITY - DECLARATION CE DE CONFORMITE' - EG KONFORMITÄTSEKTLÄRUNG - DECLARACION CE DE CONFORMIDAD- ЗАЯВЛЕНИЕ О КОНФОРМНОСТИ ЕС 2006/42/CE

Dichiarazione originale	Original Declaration	Déclaration Originale	Originalerklärung	Declaración Original	Оригинальная декларация
-------------------------	----------------------	-----------------------	-------------------	----------------------	-------------------------

Noi - We - Nous - Wir - Nosotros- мы

Tigieffe s.r.l. - Via Villa Superiore N.° 82 - Luzzara (Reggio Emilia) - ITALIA

Dichiaro sotto la nostra esclusiva responsabilità che il prodotto:	Declare under our exclusive responsibility that the product:	Declarons sous notre responsabilité exclusive que le produit:	Erklären hiermit unter Übernahme der vollen Verantwortung für diese Erklärung, daß das Produkt:	Declaramos bajo nuestra exclusiva responsabilidad que el producto:	Под нашу исключительную ответственность заявляем, что изделие:
--	--	---	---	--	--

Piattaforma di Lavoro Elevabile
Mobile Elevating Work Platform
Plates-forme Elévatrice Mobiles de Personnel
Fahrbare Hubarbeitsbühnen
Plataforma Elevadora Móvil de Personal
Платформа для высотного работ

Modello - Model - Modèle Typ - Modelo-МОДЕЛЬ	N° Chassis - Chassis No. N° Chassis - Fahrgestellnr - N° Chassis - Номер Рама	Anno - Year - Année Baujahr - Ano - Год
X10 EW WIND	XXXXXXXXXX	XXXXXXXXXX

Al quale questa dichiarazione si riferisce è conforme alle direttive 2006/42/CE, 2004/108/CE, e al modello certificato da:	To which this declaration refers is in compliance with the directives 2006/42/CE, 2004/108/CE, and with the model certified by:	Faisant l'objet de la présente déclaration est conforme aux directives 2006/42/CE, 2004/108/CE, et au modèle certifié par	Auf das sich die vorliegende Erklärung bezieht, den 2006/42/CE, 2004/108/CE, Richtlinien und dem von:	Al cual esta declaración se refiere cumple las directivas 2006/42/CE, 2004/108/CE, y el modelo certificado por:	К которой это заявление относится, соответствует директивами 2006/42/CE, 2004/108/CE, и сертифицированной модели из:
--	---	---	---	---	--

ICEPI SPA VIA P. BELIZZI, 29/31/33 29100 PIACENZA (ITALIA)

N. di identificazione 0066

con il seguente numero di certificazione:	with the following certification number:	avec le numéro de certification suivant:	Zertifizierten Modell mit folgender Zertifizierungsnummer:	con el siguiente número de certificación:	со следующим сертифицированным номером:
---	--	--	--	---	---

N.Certificato - Certificate No. - N° du certificat - Bestätigungnummer - N° de certificado - Номер Сертификата

10DM4MA43

e alle norme seguenti:	and with the following standards:	et aux normes suivantes:	die Erklärung entspricht den folgenden Normen:	y a las siguientes normas:	и со следующими нормами:
EN 280 :2001 prEN 280:2009 EN ISO 12100-1:2003 EN ISO 12100-2:2003 EN ISO 60204-1:2006					

Il firmatario di questa dichiarazione di conformità è autorizzato a costituire il Fascicolo Tecnico.	The signatory of this conformity declaration is authorized to set up the Technical File.	Le signataire de cette déclaration de conformité est autorisé à constituer le Dossier Technique.	Der Unterzeichner dieser Konformitätserklärung ist autorisiert, das technische Unterlagen abzufassen.	El firmante de esta declaración de conformidad está autorizado a crear el Expediente Técnico.	Лицо, подписавшее это заявление о соответствии, уполномочено составить техническую документацию оборудования.
--	--	--	---	---	---

Luzzara (RE), data-date-date-Datum-fecha-Дата

.....
Virgilio Ferramola

(Il legale rappresentante - The legal representative)



AIRO È UNA DIVISIONE TIGIEFFE SRL - VIA VILLA SUPERIORE, 82 -42045 LUZZARA (RE)

TEL. +39 0522 977365 FAX +39 0522 977015

DICHIARAZIONE CE DI CONFORMITA' - CE DECLARATION OF CONFORMITY - DECLARATION CE DE CONFORMITE' - EG KONFORMITÄTSEKTLÄRUNG - DECLARACION CE DE CONFORMIDAD- ЗАЯВЛЕНИЕ О КОНФОРМНОСТИ ЕС 2006/42/CE

Dichiarazione originale	Original Declaration	Déclaration Originale	Originalerklärung	Declaración Original	Оригинальная декларация
-------------------------	----------------------	-----------------------	-------------------	----------------------	-------------------------

Noi - We - Nous - Wir - Nosotros- мы

Tigieffe s.r.l. - Via Villa Superiore N.° 82 - Luzzara (Reggio Emilia) - ITALIA

Dichiaro sotto la nostra esclusiva responsabilità che il prodotto:	Declare under our exclusive responsibility that the product:	Declarons sous notre responsabilité exclusive que le produit:	Erklären hiermit unter Übernahme der vollen Verantwortung für diese Erklärung, daß das Produkt:	Declaramos bajo nuestra exclusiva responsabilidad que el producto:	Под нашу исключительную ответственность заявляем, что изделие:
--	--	---	---	--	--

Piattaforma di Lavoro Elevabile
Mobile Elevating Work Platform
Plates-forme Elévatrice Mobiles de Personnel
Fahrbare Hubarbeitsbühnen
Plataforma Elevadora Móvil de Personal
Платформа для высотного работ

Modello - Model - Modèle Typ - Modelo-МОДЕЛЬ	N° Chassis - Chassis No. N° Chassis - Fahrgestellnr - N° Chassis - Номер Рама	Anno - Year - Année Baujahr - Ano -Год
X12 EN	XXXXXXXXXX	XXXXXXXXXX

Al quale questa dichiarazione si riferisce è conforme alle direttive 2006/42/CE, 2004/108/CE, e al modello certificato da:	To which this declaration refers is in compliance with the directives 2006/42/CE, 2004/108/CE, and with the model certified by:	Faisant l'objet de la présente déclaration est conforme aux directives 2006/42/CE, 2004/108/CE, et au modèle certifié par	Auf das sich die vorliegende Erklärung bezieht, den 2006/42/CE, 2004/108/CE, Richtlinien und dem von:	Al cual esta declaración se refiere cumple las directivas 2006/42/CE, 2004/108/CE, y el modelo certificado por:	К которой это заявление относится, соответствует директивами 2006/42/CE, 2004/108/CE, и сертифицированной модели из:
--	---	---	---	---	--

ICEPI SPA VIA P. BELIZZI, 29/31/33 29100 PIACENZA (ITALIA)

N. di identificazione 0066

con il seguente numero di certificazione:	with the following certification number:	avec le numéro de certification suivant:	Zertifizierten Modell mit folgender Zertifizierungsnummer:	con el siguiente número de certificación:	со следующим сертифицированным номером:
---	--	--	--	---	---

N.Certificato - Certificate No. - N° du certificat - Bestätigungnummer - N° de certificado - Номер Сертификата

10DM4MA44

e alle norme seguenti:	and with the following standards:	et aux normes suivantes:	die Erklärung entspricht den folgenden Normen:	y a las siguientes normas:	и со следующими нормами:
------------------------	-----------------------------------	--------------------------	--	----------------------------	--------------------------

EN 280 :2001 prEN 280:2009 EN ISO 12100-1:2003 EN ISO 12100-2:2003 EN ISO 60204-1:2006

Il firmatario di questa dichiarazione di conformità è autorizzato a costituire il Fascicolo Tecnico.	The signatory of this conformity declaration is authorized to set up the Technical File.	Le signataire de cette déclaration de conformité est autorisé à constituer le Dossier Technique.	Der Unterzeichner dieser Konformitätserklärung ist autorisiert, das technische Unterlagen abzufassen.	El firmante de esta declaración de conformidad está autorizado a crear el Expediente Técnico.	Лицо, подписавшее это заявление о соответствии, уполномочено составить техническую документацию оборудования.
--	--	--	---	---	---

Luzzara (RE), data-date-date-Datum-fecha-Дата

Virginio Ferramola

(Il legale rappresentante - The legal representative)

AIRO

Uso e manutenzione – Serie X

Pag. 120



AIRO È UNA DIVISIONE TIGIEFFE SRL - VIA VILLA SUPERIORE, 82 -42045 LUZZARA (RE)

TEL. +39 0522 977365 FAX +39 0522 977015

DICHIARAZIONE CE DI CONFORMITA' - CE DECLARATION OF CONFORMITY - DECLARATION CE DE CONFORMITE' - EG KONFORMITÄTSEKTLÄRUNG - DECLARACION CE DE CONFORMIDAD- ЗАЯВЛЕНИЕ О КОНФОРМНОСТИ ЕС 2006/42/CE

Dichiarazione originale	Original Declaration	Déclaration Originale	Originalerklärung	Declaración Original	Оригинальная декларация
-------------------------	----------------------	-----------------------	-------------------	----------------------	-------------------------

Noi - We - Nous - Wir - Nosotros- мы

Tigieffe s.r.l. - Via Villa Superiore N.° 82 - Luzzara (Reggio Emilia) - ITALIA

Dichiaro sotto la nostra esclusiva responsabilità che il prodotto:	Declare under our exclusive responsibility that the product:	Declarons sous notre responsabilité exclusive que le produit:	Erklären hiermit unter Übernahme der vollen Verantwortung für diese Erklärung, daß das Produkt:	Declaramos bajo nuestra exclusiva responsabilidad que el producto:	Под нашу исключительную ответственность заявляем, что изделие:
--	--	---	---	--	--

Piattaforma di Lavoro Elevabile
Mobile Elevating Work Platform
Plates-forme Elévatrice Mobiles de Personnel
Fahrbare Hubarbeitsbühnen
Plataforma Elevadora Móvil de Personal
Платформа для высотного работ

Modello - Model - Modèle Typ - Modelo-МОДЕЛЬ	N° Chassis - Chassis No. N° Chassis - Fahrgestellnr - N° Chassis - Номер Рама	Anno - Year - Année Baujahr - Ano -Год
X12 EW	XXXXXXXXXX	XXXXXXXXXX

Al quale questa dichiarazione si riferisce è conforme alle direttive 2006/42/CE, 2004/108/CE, e al modello certificato da:	To which this declaration refers is in compliance with the directives 2006/42/CE, 2004/108/CE, and with the model certified by:	Faisant l'objet de la présente déclaration est conforme aux directives 2006/42/CE, 2004/108/CE, et au modèle certifié par	Auf das sich die vorliegende Erklärung bezieht, den 2006/42/CE, 2004/108/CE, Richtlinien und dem von:	Al cual esta declaración se refiere cumple las directivas 2006/42/CE, 2004/108/CE, y el modelo certificado por:	К которой это заявление относится, соответствует директивами 2006/42/CE, 2004/108/CE, и сертифицированной модели из:
--	---	---	---	---	--

ICEPI SPA VIA P. BELIZZI, 29/31/33 29100 PIACENZA (ITALIA)

N. di identificazione 0066

con il seguente numero di certificazione:	with the following certification number:	avec le numéro de certification suivant:	Zertifizierten Modell mit folgender Zertifizierungsnummer:	con el siguiente número de certificación:	со следующим сертифицированным номером:
---	--	--	--	---	---

N.Certificato - Certificate No. - N° du certificat - Bestätigungnummer - N° de certificado - Номер Сертификата

10DM4MA45

e alle norme seguenti:	and with the following standards:	et aux normes suivantes:	die Erklärung entspricht den folgenden Normen:	y a las siguientes normas:	и со следующими нормами:
------------------------	-----------------------------------	--------------------------	--	----------------------------	--------------------------

EN 280 :2001 prEN 280:2009 EN ISO 12100-1:2003 EN ISO 12100-2:2003 EN ISO 60204-1:2006

Il firmatario di questa dichiarazione di conformità è autorizzato a costituire il Fascicolo Tecnico.	The signatory of this conformity declaration is authorized to set up the Technical File.	Le signataire de cette déclaration de conformité est autorisé à constituer le Dossier Technique.	Der Unterzeichner dieser Konformitätserklärung ist autorisiert, das technische Unterlagen abzufassen.	El firmante de esta declaración de conformidad está autorizado a crear el Expediente Técnico.	Лицо, подписавшее это заявление о соответствии, уполномочено составить техническую документацию оборудования.
--	--	--	---	---	---

Luzzara (RE), data-date-date-Datum-fecha-Дата

.....
Virginio Ferramola

(Il legale rappresentante - The legal representative)

AIRO

Uso e manutenzione – Serie X

Pag. 121



AIRO È UNA DIVISIONE TIGIEFFE SRL - VIA VILLA SUPERIORE, 82 -42045 LUZZARA (RE)
 TEL. +39 0522 977365 FAX +39 0522 977015

DICHIARAZIONE CE DI CONFORMITA' - CE DECLARATION OF CONFORMITY - DECLARATION CE DE CONFORMITE' -
 EG KONFORMITÄTSEKTLÄRUNG - DECLARACION CE DE CONFORMIDAD- ЗАЯВЛЕНИЕ О КОНФОРМНОСТИ ЕС
 2006/42/CE

Dichiarazione originale	Original Declaration	Déclaration Originale	Originalerklärung	Declaración Original	Оригинальная декларация
Noi - We - Nous - Wir - Nosotros- мы					

Tigieffe s.r.l. - Via Villa Superiore N.° 82 - Luzzara (Reggio Emilia) - ITALIA

Dichiaro sotto la nostra esclusiva responsabilità che il prodotto:	Declare under our exclusive responsibility that the product:	Declarons sous notre responsabilité exclusive que le produit:	Erklären hiermit unter Übernahme der vollen Verantwortung für diese Erklärung, daß das Produkt:	Declaramos bajo nuestra exclusiva responsabilidad que el producto:	Под нашу исключительную ответственность заявляем, что изделие:
--	--	---	---	--	--

Piattaforma di Lavoro Elevabile
 Mobile Elevating Work Platform
 Plates-forme Elévatrice Mobiles de Personnel
 Fahrbare Hubarbeitsbühnen
 Plataforma Elevadora Móvil de Personal
 Платформа для высотного работ

Modello - Model - Modèle Typ - Modelo-МОДЕЛЬ	N° Chassis - Chassis No. N° Chassis - Fahrgestellnr - N° Chassis - Номер Рама	Anno - Year - Année Baujahr - Ano - Год
X12 EW WIND	XXXXXXXXXX	XXXXXXXXXX

Al quale questa dichiarazione si riferisce è conforme alle direttive 2006/42/CE, 2004/108/CE, e al modello certificato da:	To which this declaration refers is in compliance with the directives 2006/42/CE, 2004/108/CE, and with the model certified by:	Faisant l'objet de la présente déclaration est conforme aux directives 2006/42/CE, 2004/108/CE, et au modèle certifié par	Auf das sich die vorliegende Erklärung bezieht, den 2006/42/CE, 2004/108/CE, Richtlinien und dem von:	Al cual esta declaración se refiere cumple las directivas 2006/42/CE, 2004/108/CE, y el modelo certificado por:	К которой это заявление относится, соответствует директивами 2006/42/CE, 2004/108/CE, и сертифицированной модели из:
--	---	---	---	---	--

ICEPI SPA VIA P. BELIZZI, 29/31/33 29100 PIACENZA (ITALIA)

N. di identificazione 0066

con il seguente numero di certificazione:	with the following certification number:	avec le numéro de certification suivant:	Zertifizierten Modell mit folgender Zertifizierungsnummer:	con el siguiente número de certificación:	со следующим сертифицированным номером:
---	--	--	--	---	---

N.Certificato - Certificate No. - N° du certificat - Bestätigungnummer - N° de certificado - Номер Сертификата

10DM4MA46

e alle norme seguenti:	and with the following standards:	et aux normes suivantes:	die Erklärung entspricht den folgenden Normen:	y a las siguientes normas:	и со следующими нормами:
------------------------	-----------------------------------	--------------------------	--	----------------------------	--------------------------

EN 280 :2001 prEN 280:2009 EN ISO 12100-1:2003 EN ISO 12100-2:2003 EN ISO 60204-1:2006

Il firmatario di questa dichiarazione di conformità è autorizzato a costituire il Fascicolo Tecnico.	The signatory of this conformity declaration is authorized to set up the Technical File.	Le signataire de cette déclaration de conformité est autorisé à constituer le Dossier Technique.	Der Unterzeichner dieser Konformitätserklärung ist autorisiert, das technische Unterlagen abzufassen.	El firmante de esta declaración de conformidad está autorizado a crear el Expediente Técnico.	Лицо, подписавшее это заявление о соответствии, уполномочено составить техническую документацию оборудования.
--	--	--	---	---	---

Luzzara (RE), data-date-date-Datum-fecha-Дата

.....
 Virginio Ferramola
 (Il legale rappresentante - The legal representative)



AIRO È UNA DIVISIONE TIGIEFFE SRL - Via VILLA SUPERIORE, 82 -42045 LUZZARA (RE)

TEL. +39 0522 977365 FAX +39 0522 977015

DICHIARAZIONE CE DI CONFORMITA' - CE DECLARATION OF CONFORMITY - DECLARATION CE DE CONFORMITE' - EG KONFORMITÄTSEKTLÄRUNG - DECLARACION CE DE CONFORMIDAD - ЗАЯВЛЕНИЕ О КОНФОРМНОСТИ ЕС 2006/42/CE

Dichiarazione originale	Original Declaration	Déclaration Originale	Originalerklärung	Declaración Original	Оригинальная декларация
-------------------------	----------------------	-----------------------	-------------------	----------------------	-------------------------

Noi - We - Nous - Wir - Nosotros - мы

Tigieffe s.r.l. - Via Villa Superiore N.° 82 - Luzzara (Reggio Emilia) - ITALIA

Dichiaro sotto la nostra esclusiva responsabilità che il prodotto:	Declare under our exclusive responsibility that the product:	Declarons sous notre responsabilité exclusive que le produit:	Erklären hiermit unter Übernahme der vollen Verantwortung für diese Erklärung, daß das Produkt:	Declaramos bajo nuestra exclusiva responsabilidad que el producto:	Под нашу исключительную ответственность заявляем, что изделие:
--	--	---	---	--	--

Piattaforma di Lavoro Elevabile
Mobile Elevating Work Platform
Plates-forme Elévatrice Mobiles de Personnel
Fahrbare Hubarbeitsbühnen
Plataforma Elevadora Móvil de Personal
Платформа для высотного работ

Modello - Model - Modèle Typ - Modelo-МОДЕЛЬ	N° Chassis - Chassis No. N° Chassis - Fahrgestellnr - N° Chassis - Номер Рама	Anno - Year - Année Baujahr - Ano - Год
X14 EW	XXXXXXXXXX	XXXXXXXXXX

Al quale questa dichiarazione si riferisce è conforme alle direttive 2006/42/CE, 2004/108/CE, e al modello certificato da:	To which this declaration refers is in compliance with the directives 2006/42/CE, 2004/108/CE, and with the model certified by:	Faisant l'objet de la présente déclaration est conforme aux directives 2006/42/CE, 2004/108/CE, et au modèle certifié par	Auf das sich die vorliegende Erklärung bezieht, den 2006/42/CE, 2004/108/CE, Richtlinien und dem von:	Al cual esta declaración se refiere cumple las directivas 2006/42/CE, 2004/108/CE, y el modelo certificado por:	К которой это заявление относится, соответствует директивами 2006/42/CE, 2004/108/CE, и сертифицированной модели из:
--	---	---	---	---	--

ICEPI SPA VIA P. BELIZZI, 29/31/33 29100 PIACENZA (ITALIA)

N. di identificazione 0066

con il seguente numero di certificazione:	with the following certification number:	avec le numéro de certification suivant:	Zertifizierten Modell mit folgender Zertifizierungsnummer:	con el siguiente número de certificación:	со следующим сертифицированным номером:
---	--	--	--	---	---

N.Certificato - Certificate No. - N° du certificat - Bestätigungsnummer - N° de certificado - Номер Сертификата

10DM4MA47

e alle norme seguenti:	and with the following standards:	et aux normes suivantes:	die Erklärung entspricht den folgenden Normen:	y a las siguientes normas:	и со следующими нормами:
------------------------	-----------------------------------	--------------------------	--	----------------------------	--------------------------

EN 280 :2001 prEN 280:2009 EN ISO 12100-1:2003 EN ISO 12100-2:2003 EN ISO 60204-1:2006

Il firmatario di questa dichiarazione di conformità è autorizzato a costituire il Fascicolo Tecnico.	The signatory of this conformity declaration is authorized to set up the Technical File.	Le signataire de cette déclaration de conformité est autorisé à constituer le Dossier Technique.	Der Unterzeichner dieser Konformitätserklärung ist autorisiert, das technische Unterlagen abzufassen.	El firmante de esta declaración de conformidad está autorizado a crear el Expediente Técnico.	Лицо, подписавшее это заявление о соответствии, уполномочено составить техническую документацию оборудования.
--	--	--	---	---	---

Luzzara (RE), data-date-date-Datum-fecha-Дата

.....
Virginio Ferramola

(Il legale rappresentante - The legal representative)



AIRO è una divisione TIGIEFFE SRL
Via Villasuperiore , 82 -42045 Luzzara (RE) ITALIA-
' +39-0522-977365 - 7 +39-0522-977015
WEB: www.airo.com