

MovieBird 35 Instruction Manual



Technical Support:

Piotr Czernecki: pcz@moviebird.com, Phone - +48 782479077

Maciej Hełm: mhelm@moviebird.com, Phone +48 513141258

Table of Contents

Part 1. Safety Guideline/Points	3
Safety Guideline	3
Safety Points	5
Part 2. Crane Mechanics	10
Part 3. Electronics/Troubleshooting	31

1. Safety Guideline/Points

The manufacturer recommends the following safety procedures: in order to reduce the possibility of an accident, every camera crane with arm range above 30 feet (9 meters) should be operated by at least two trained technicians (grips).

In case of MovieBird cranes it concerns models: MB-30, MB-35, MB-45, MB-50XL, MB-52, MB-62.

Safety Guideline

1. The assembly instructions **must** be read and understood before setup or operation. The crane may only be assembled in accordance with the manufacturer's instruction manual. The manufacturer's technical specifications and limits must be adhered to at all times and in no way exceeded.
2. The MovieBird Telescopic Crane may only be setup or operated by trained and experienced personnel.
3. The crane may not be assembled or operated under the influence of alcohol, drugs or any other intoxicating substances.
4. The manufacturer accepts no liability for damages, injuries, or accidents occurring due to negligence by the crane operator, misuse of the crane or disregarding the instruction manual.
5. The camera crane must be used on the even terrain.
6. Make sure there are no electronic cables and electronic appliances within the movement range of the crane arm when it is left unattended in assembled state. If the pan and tilt remote head is higher than the central pivot section the crane system should not be left unsupervised.
7. After setup of the crane the pan and tilt remote head should be positioned under the central pivot section. If the pan and tilt remote head is higher than the central pivot section the crane system should not be left unsupervised.
8. Make sure that there are no wires with electric power which has a higher voltage than the safety level within the movement range of the whole crane system. The power supply cable should not be pulled when swivelling the crane arm.
9. Avoid abruptly swivelling or stopping the crane as it may cause the crane to fall.
10. The crane must not be used in environments with wind speed faster than 5.5–7.9 m/s.
11. When the camera crane is used during wet weather the pan and tilt remote head, control box and control bar must be protected against the rain as the control box is strictly prohibited from making contact with water.

12. When the crane is in operation no one must enter the enclosure of the crane arm. You must avoid anyone standing directly under the crane.
13. No loose objects may be stored or placed in or on the crane.
14. Ensure the location where the crane is installed can support the double overall weight of the crane, (including the counterweight) and operators.
15. When the control system is working the gear of the remote head is not allowed to be turned, if it needs to be adjusted the power supply should be switched off before the adjustment is made.
16. In the interest of safety when operating the crane, abrupt or sudden movement of the crane should be avoided.
17. Only original accessories manufactured by MovieBird Technologies may be used with the crane.
18. Check that there are no objects placed around or on the rail of the moving counterweight trolley.
19. The crane arm must not be extended without another person holding the enclosure of the crane arm tightly.
20. The first three sections (All moving sections) of the crane arm must not be held.

Safety Points

1. MovieBird telescopic crane to be operated and assembled by a trained MovieBird Operator.
2. MovieBird telescopic crane not to be left unattended without first securing arm to base with straps provided.
3. MovieBird telescopic crane only to be lifted by its own lifting straps using handles provided on cranes.
4. Care must be taken when lifting counterweights onto saddle.
5. All guards to be left in place on MovieBird during operation (unless removed by MovieBird operator for adjustment only and then to be re-fitted before re-use of MovieBird)
6. Electronic & mechanical “stops” to be in full safe working order (to be verified by MovieBird Operator)
7. Brake to be operated by MovieBird operator only.
8. Base must be maintained horizontally in a level position when in use.
9. All personnel in the vicinity of the MovieBird are to be made aware of its scope and speed of movement.
10. It is forbidden to operate the crane without all of the safety covers installed.
11. To reduce the possibility of injuries, the crane must be operated by at least two persons.
12. It is forbidden to remove or add any weight to the crane without permission of the crane operator. Any added/removed weight will cause unbalancing of the crane which may lead to serious accident.
13. Any time during operating of the crane, the crane operator must have at least one hand holding the crane. Any hand-free movement of the crane arm is forbidden.
14. All of the service points, safety covers, adjustment screws – if not stated otherwise in this manual – are to be handled only by certified MovieBird technician.
15. Any people in the vicinity of the crane must be informed about the intended movement of the crane, it’s work characteristics and safety guidelines included in this manual.

Safety Straps / how to transport

When not in use, or during transport, the crane should always be secured by two safety straps – one at the front and one at the back. On the dolly, fasten the safety straps with snap hooks at the eyebolts. On the crane, pull the straps through the holes provided. This prevents the straps from slipping off under strain or becoming detached unintentionally. Also one safety strap need to hold the last section to prevent it from jumping while being transported.

During transport, the sections need to be secured by attaching the blockade to the first and last section, exactly how it's shown at the picture below.

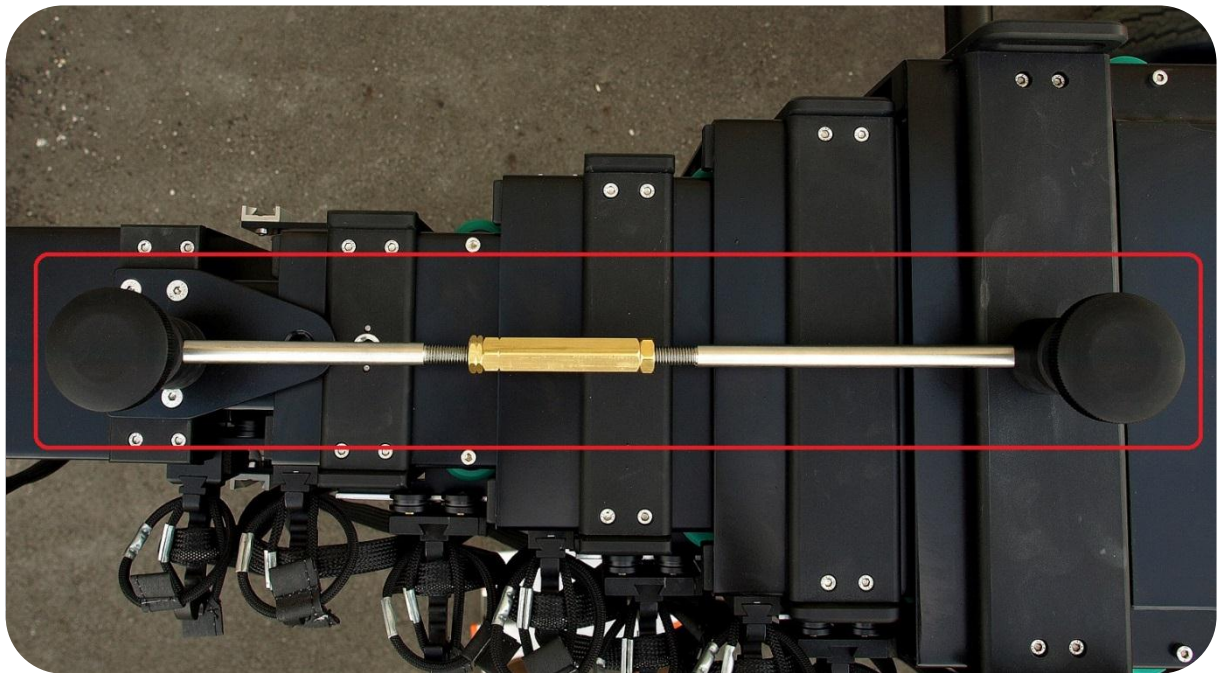

Also both breaks (pan and tilt) need to be released.

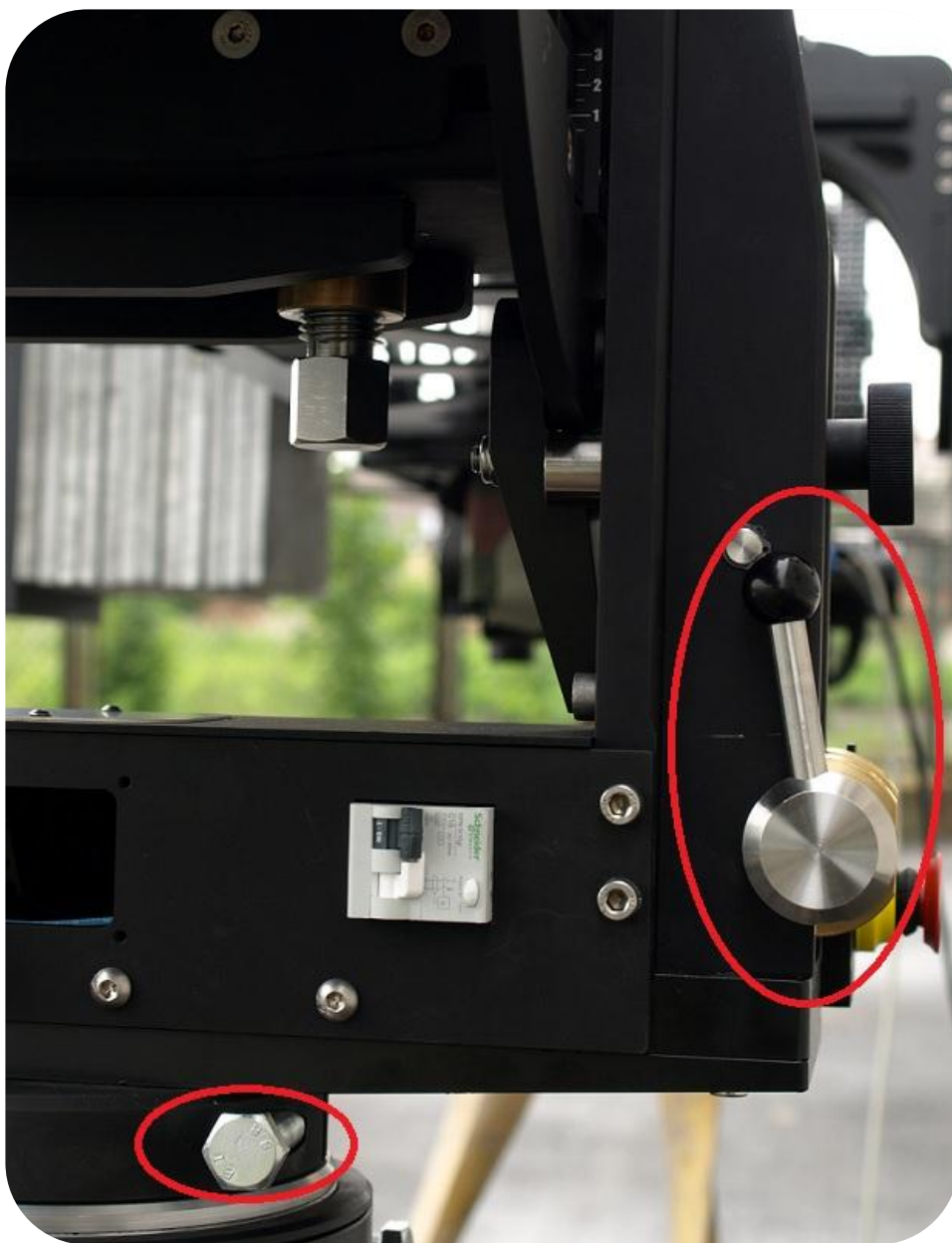

Securing the counterweights

The counterweights should always be secured by M16 bolts to prevent them from failing off.

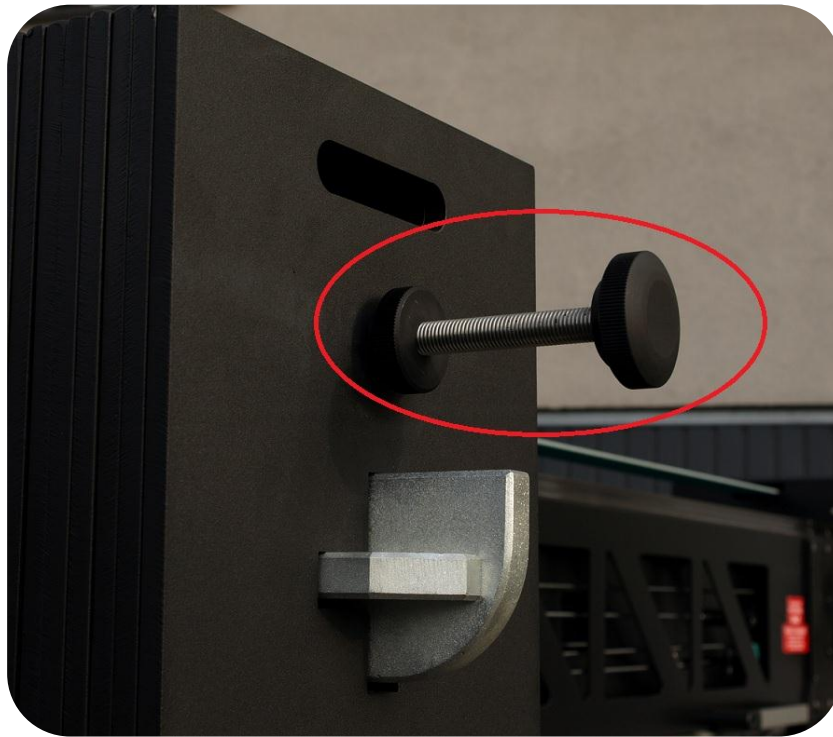

Cleaning, Maintenance, Service

The crane should never be cleaned when the electronic is switched on to avoid lethal injuries! Rails and steel wheels should be cleaned from dirty grease as often as possible to maintain best performance of the arm.

The cables should be always checked if they're tightened up properly before working with the arm. If the cables are loosened there is a risk that one of them will fall down of the drum which can cause heavy damage to the arm and is also very dangerous for the people nearby.

Also it's highly recommended to check:

- If the counterweight belt is tightened up properly and if not, to do so;
- If the chain from chain drive is tightened up properly and if not, to do so;
- If the side belt is tightened up properly and if not, to do so;

Information about above steps are described deeper in this instruction.

Protective Covers

There is always a danger of someone gripping the crane beam and having their hands cut off by the moving sections. It is therefore forbidden to work with a crane without the protective covers being fitted. The protective covers should only be removed for servicing and cleaning the rails and steel wheels, and must always be screwed back on afterwards. Also the electronics must be always switched off before removing the covers.

Part 2

Crane Mechanics

How to Balance The Crane

This step guide is showing an example of how to balance the crane.

1. Put 25 counterweights on each side of the crane (50 total).
2. Remove section blockade and release all the breaks (pan/tilt).

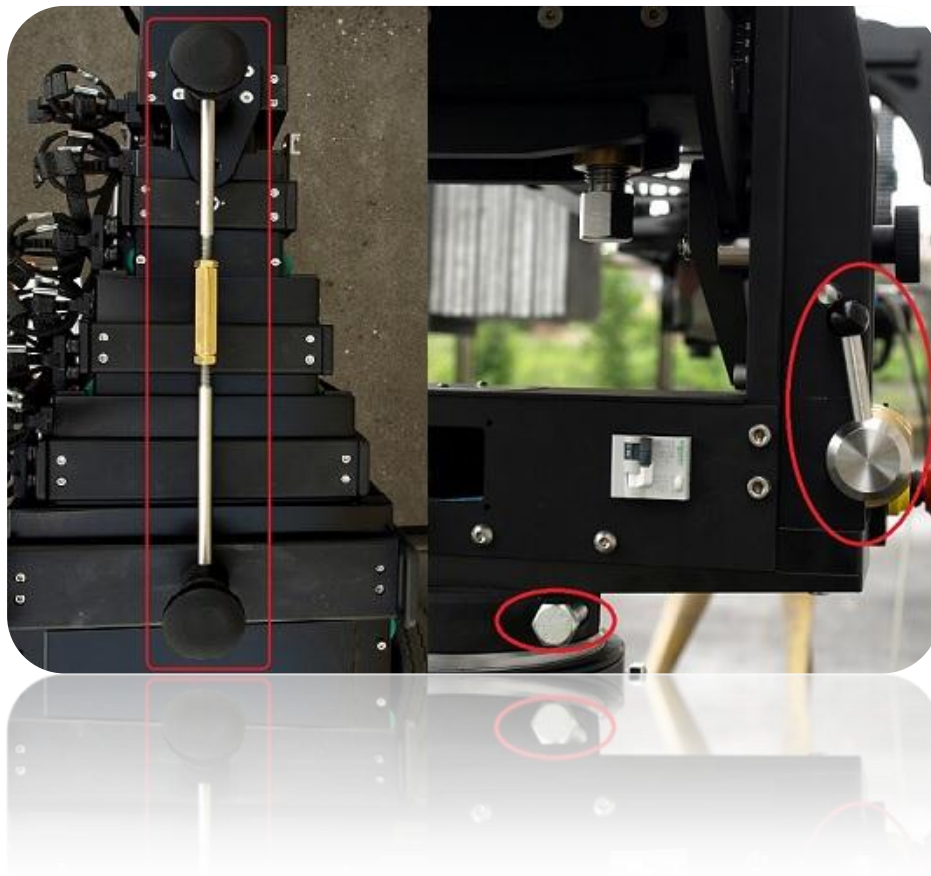

3. Extract the arm a little manually so the platform will go off from the front end stop.

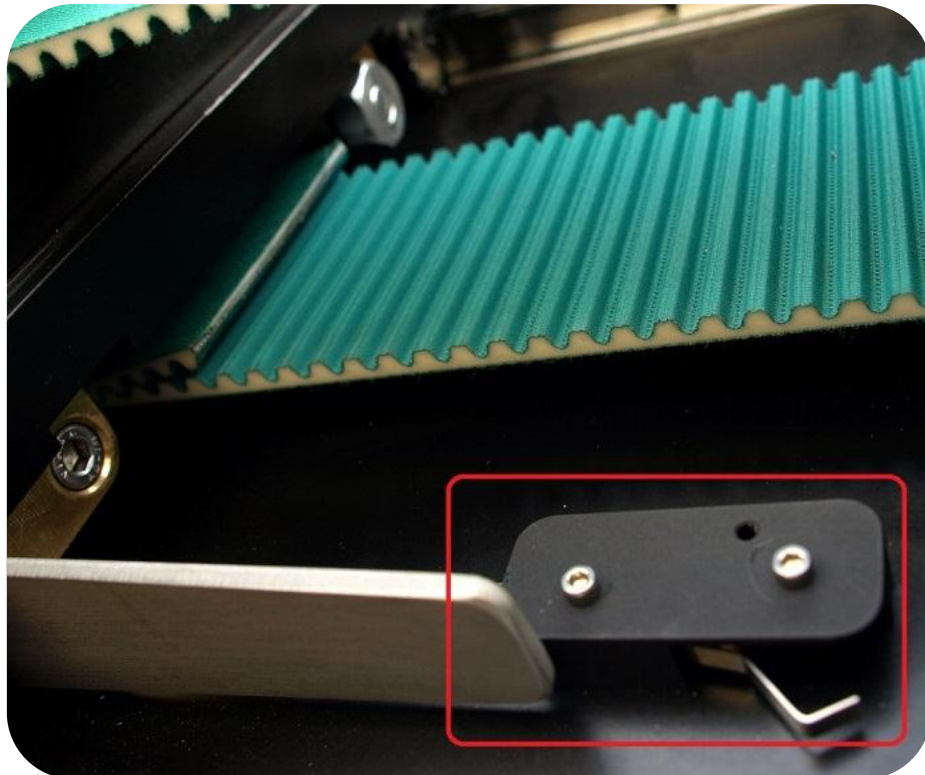

4. Turn on electronics (box, leveling head).
5. Intract the arm. This is the 1st position to balance the crane.
6. Loosen up the rear strap. 2nd person should be securing the crane. If that person is able to hold the crane then remove both straps.

7. Check which side of the crane is heavier. If it's the front then move the counterweight platform to the rear side until we get the balance (similarly if the rear side is heavier) using the screw shown at the picture below (you need to loosen up 2 screws before adjusting the platform).

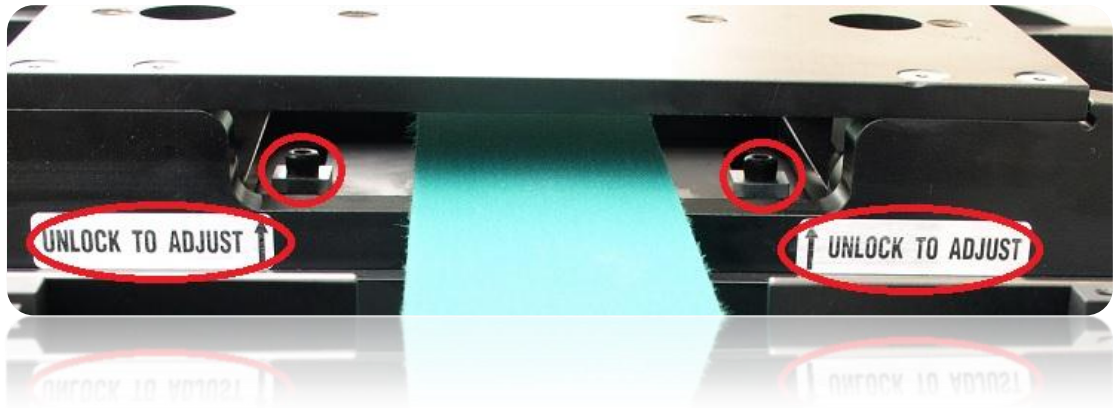

8. If the crane is still unbalanced after step 7, then we use the donuts to balance it.



9. When we got the balance on the 1st position – extract the arm until the counterweight platform reach the rear end stop (it should be on learning mode so it will move slowly – that’s what we want). On its way if one of the sides will be too heavy to hold then remove or add the counterweights depending on which side is heavier. When the arm will be extracted to the end then it’s the 2nd position to balance the crane.
10. If the front overweights – add the counterweights until balance is obtained. If the rear is heavier – remove the counterweights until balance is obtained.

note: we use all kinds of counterweights if it's necessary to add small values.

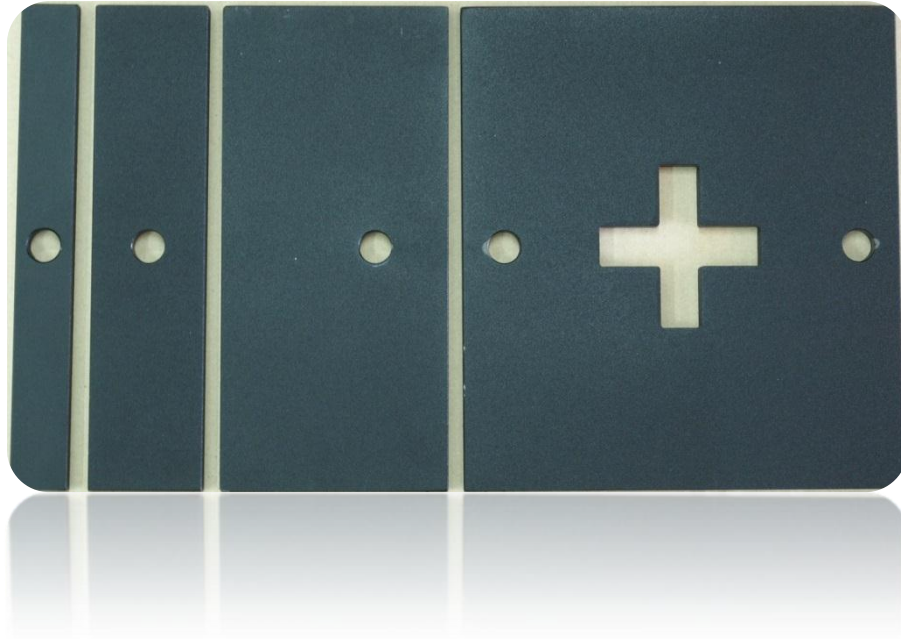

We need to remember that M16 bolts that secure the counterweights also counts in the balance process.

11. After we got the balance when the arm is extracted – intract to the 1st position to see if the balance isn't lost (it shouldn't if you followed this step guide).
12. Crane is ready to work.

Dolly

D.1. Dolly is permanently equipped with leveling jacks. We do recommend to use all of them while operating the crane for best stability and to maintain perfect level in both axes.



D.2. Track wheels are also permanently equipped into the dolly (picture above).

D.3. Crane base is equipped with pneumatic wheels. Optionally we do provide hard studio wheels also.

D.4. On the dolly there's a steering supported by 2 drawbacks connected to each other for best maneuvering of the crane. Optionally it's possible to block one of the drawback and separate it from the other one by dismounting the connecting strip under the dolly.

Column

C.1. The column is mounted onto the dolly by using four M16 screws.

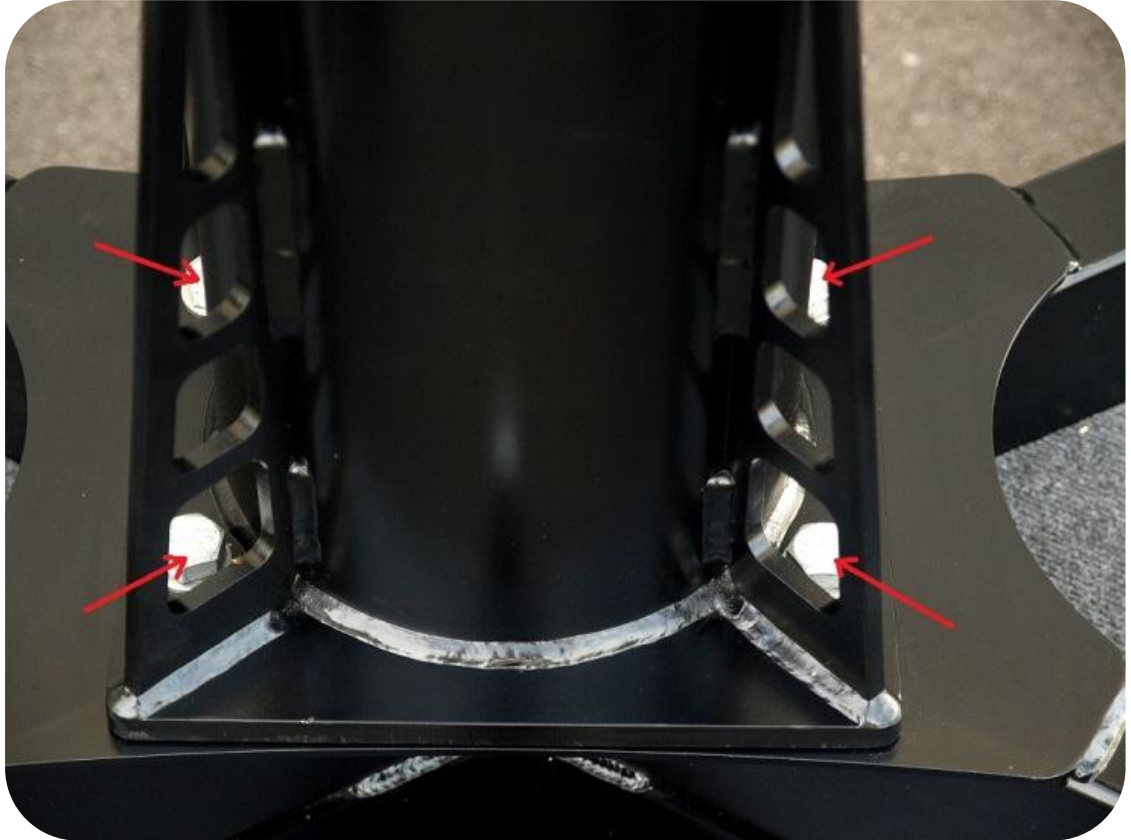

C.2. Also it's crucial to be sure that square receiver on the bottom of the column is properly engaged with the square shaft socket on the dolly.

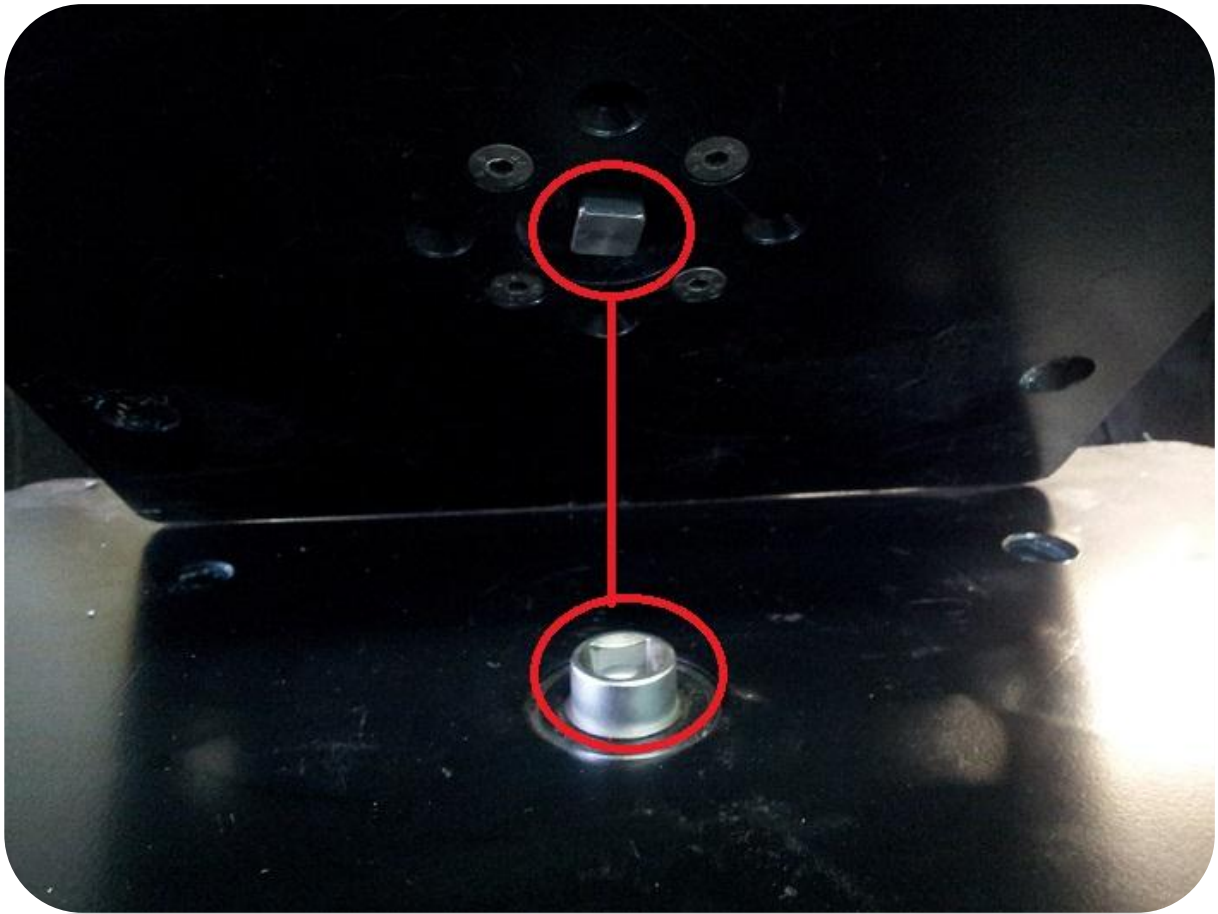

C.3. There are four screws that needs to be released before extending telescopic column and also horizontal break must be locked.

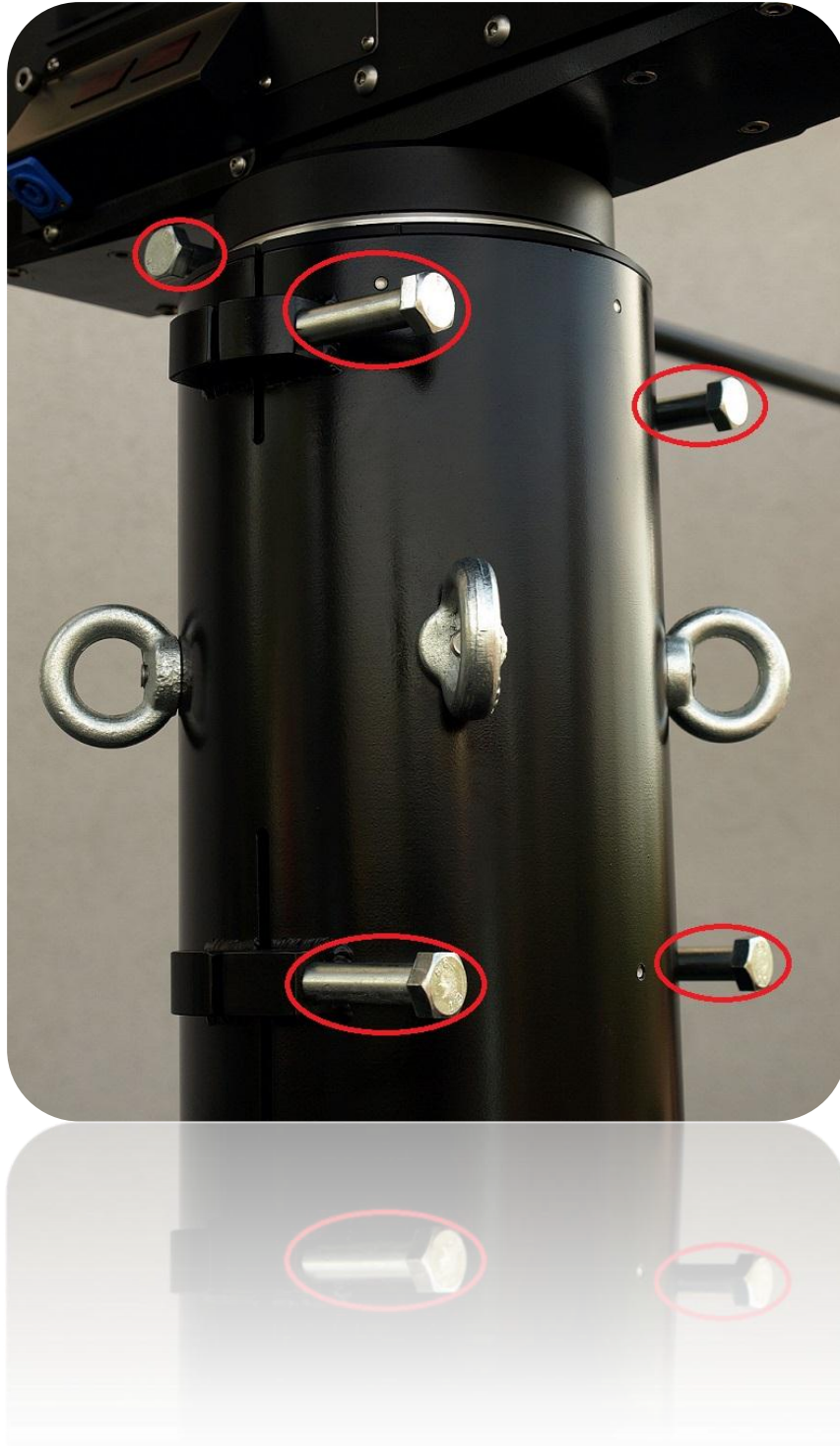

After those steps the inner column can be raised or lowered with a 24mm ratchet or by using the drill. The column can be extended by 45cm until visible marking appear.

Yoke

On the yoke there is located a power management to which you connect power supply cable. All the electronics are connected directly to the yoke (box and leveling head AC). There is voltage current displayed on the yoke. Also an emergency stop button that cuts off all the power instantly is located on the side of the yoke.

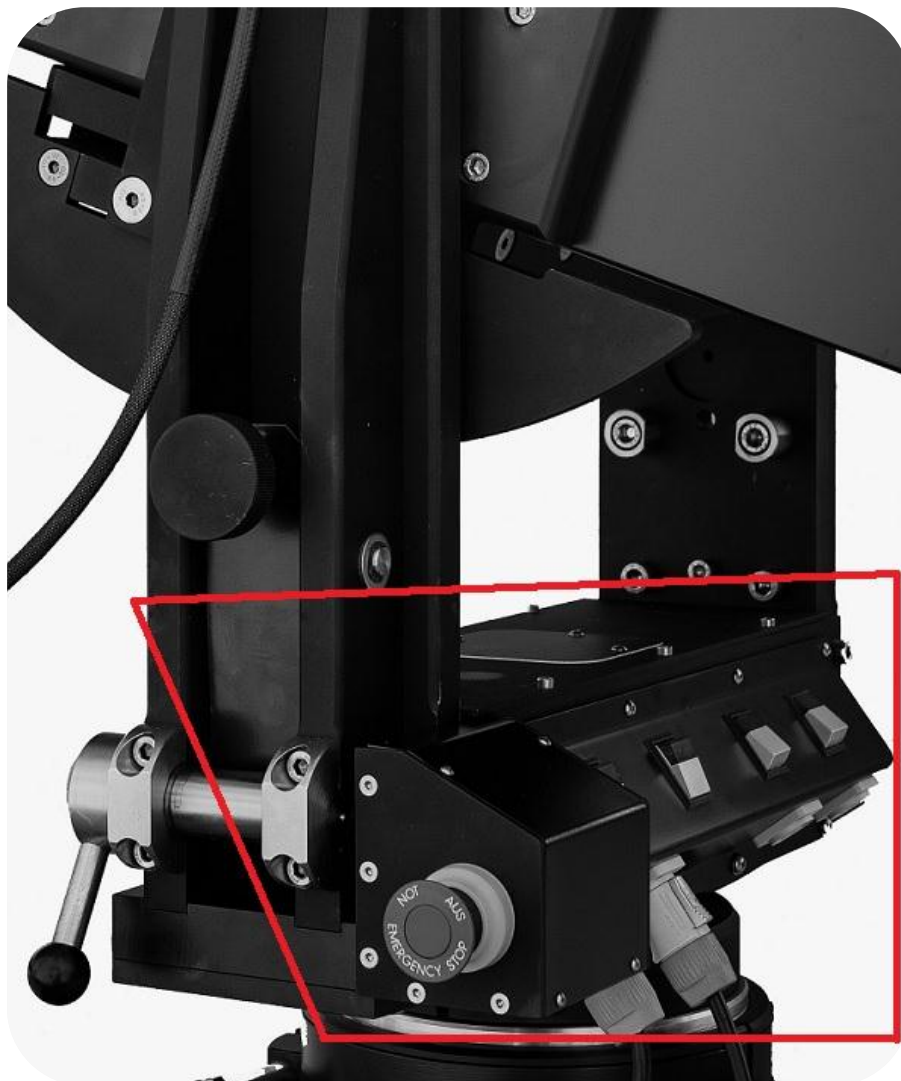

Arm

IMPORTANT: Electronics MUST be switched off before working inside of the arm. Also it is forbidden to move the sections during adjustment of crane mechanics. MovieBird does not take any responsibility if someone is maintaining the crane and don't abide above rules.

A.1. How to adjust green sliding wheels.

After some time of crane usage there is possibility that the sliding green wheels - on which sections are moving during first few meters – needs to be tuned.

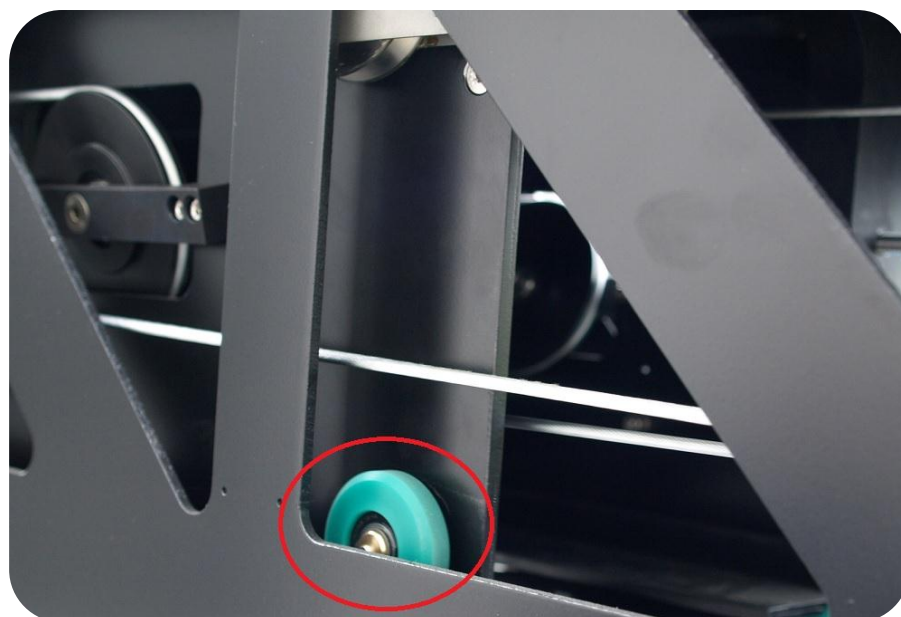

To tune up the green wheel you need to loose (don't release it) the helical screw...

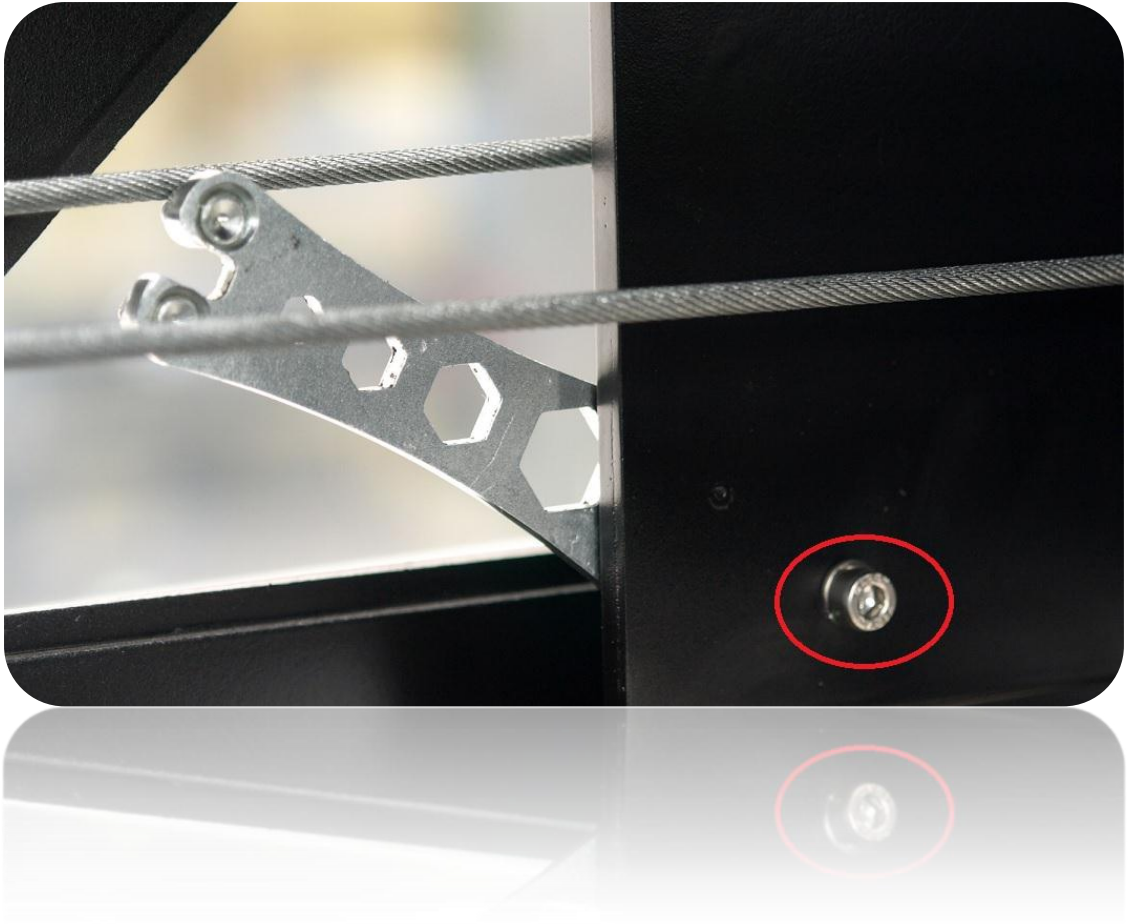

...and adjust the wheel with leveling head key. The green wheel needs to touch the section on which it is sliding on the halfway position of extracting the arm.



IMPORTANT: Electronics MUST be switched off before working inside of the arm. Also it is forbidden to move the sections during adjustment of crane mechanics. MovieBird does not take any responsibility if someone is maintaining the crane and don't abide above rules.

A.2. On the pictures you can see how to properly stretch the chain on the chain drive;

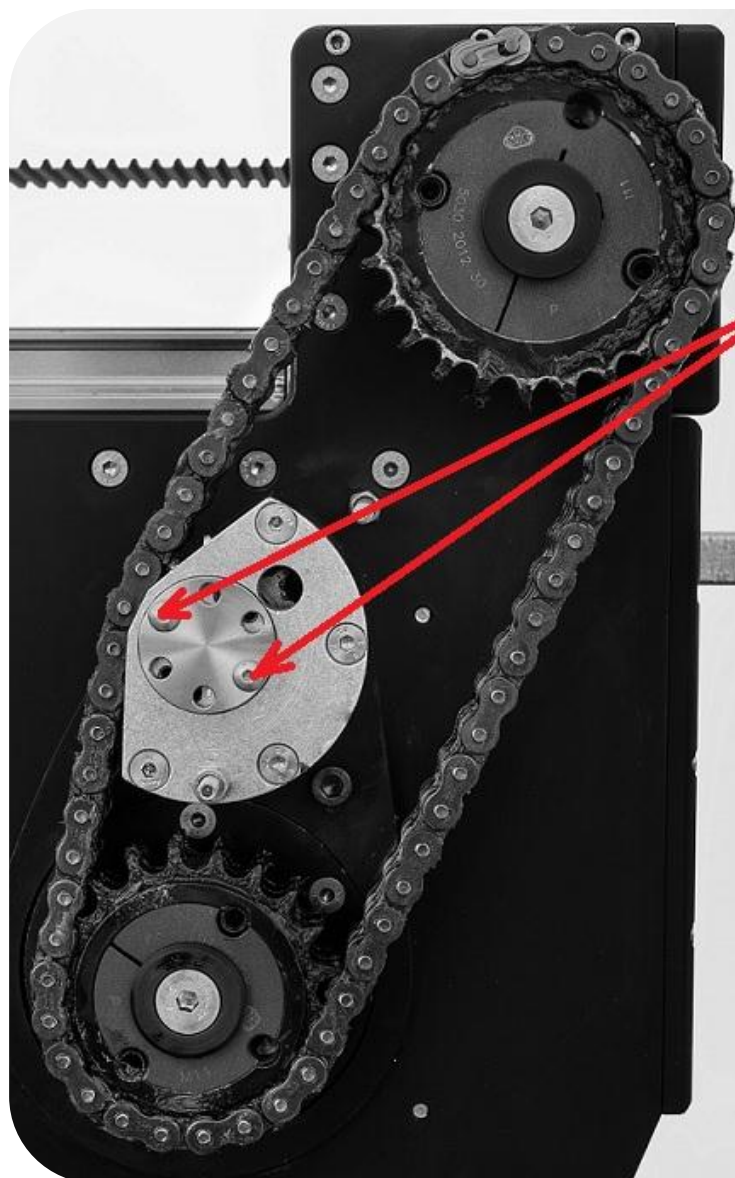

Release these screws on the chain tensor.

And after:

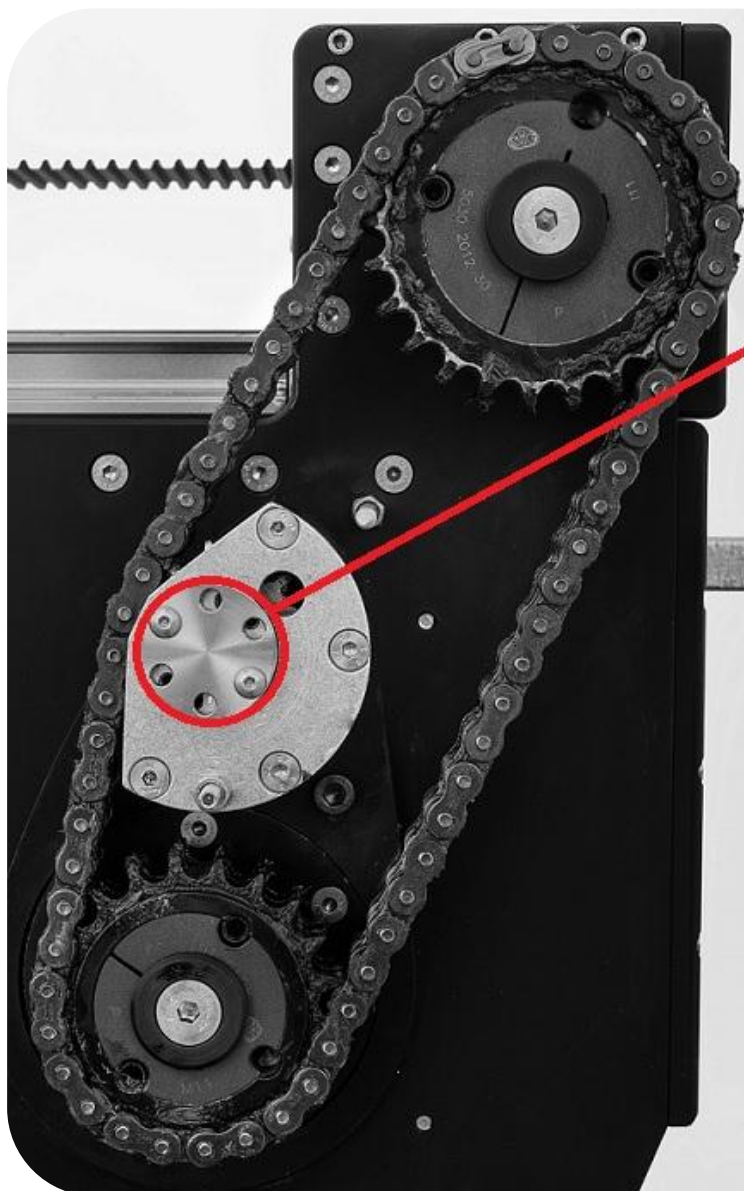

Stretch the chain using this tensor. Chain can't be stretched too much. After - attach the screws that were released before.

A.3. On the picture you can see how to properly stretch the belt on the right side of the crane;

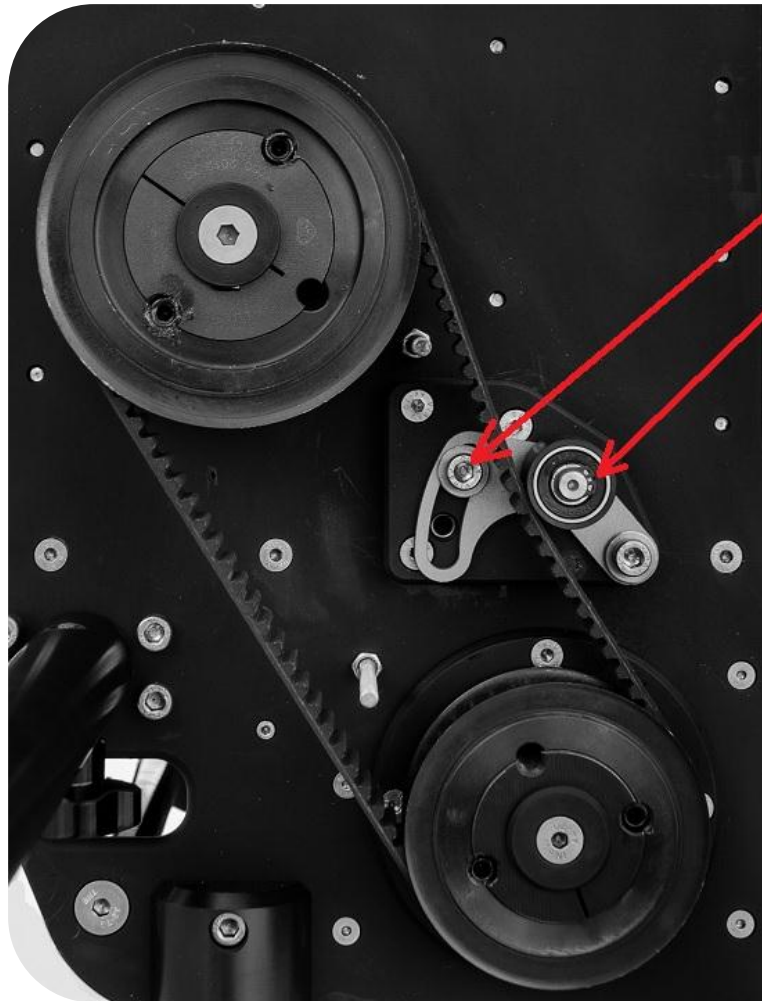

Release this screw
to adjust the
tensor to make the
belt tight enough

A.4. How to tension the cables.

Prior to cables tensioning, section covers must be removed and then visually assess the condition of the rope.

If any of the cables are damaged, depart from the tensioning and call the MovieBird service for repair.

Tensioning the cables:

- 1) The crane must be balanced and be fully loaded (50kg).
- 2) Tension check – crane lifted. Tension adjustment – crane leveled.
- 3) Expand the crane VERY SLOWLY to maximum and lift the arm to the very top.
- 4) Once again, assess the condition of the cables.
- 5) Visually assess the tension of the cables. Cables should be stretched evenly and shouldn't sag. Cables should run in the section parallel to each other and parallel to the section.
- 6) If any of the cables are not parallel to the section or are loose, the tensioning process should start from them.
- 7) Level the crane. Turn off the power. Tension the cable until it is straight in the section. Raise the arm to maximum and check the tension.
- 8) Strain the cables until the tension is even and the course of cables in sections are parallel. Check it by lifting and lowering the arm.
- 9) The crane has cables to pull out and pull in the sections. There should be a balance on the regulators. In other hand the sections can hit each other.

IMPORTANT: Electronics MUST be switched off before working inside of the arm. Also it is forbidden to move the sections during adjustment of crane mechanics. MovieBird does not take any responsibility if someone is maintaining the crane and don't abide above rules.

Here's an example of how to tension the cables.



- 1.** Release this nut.

And after:

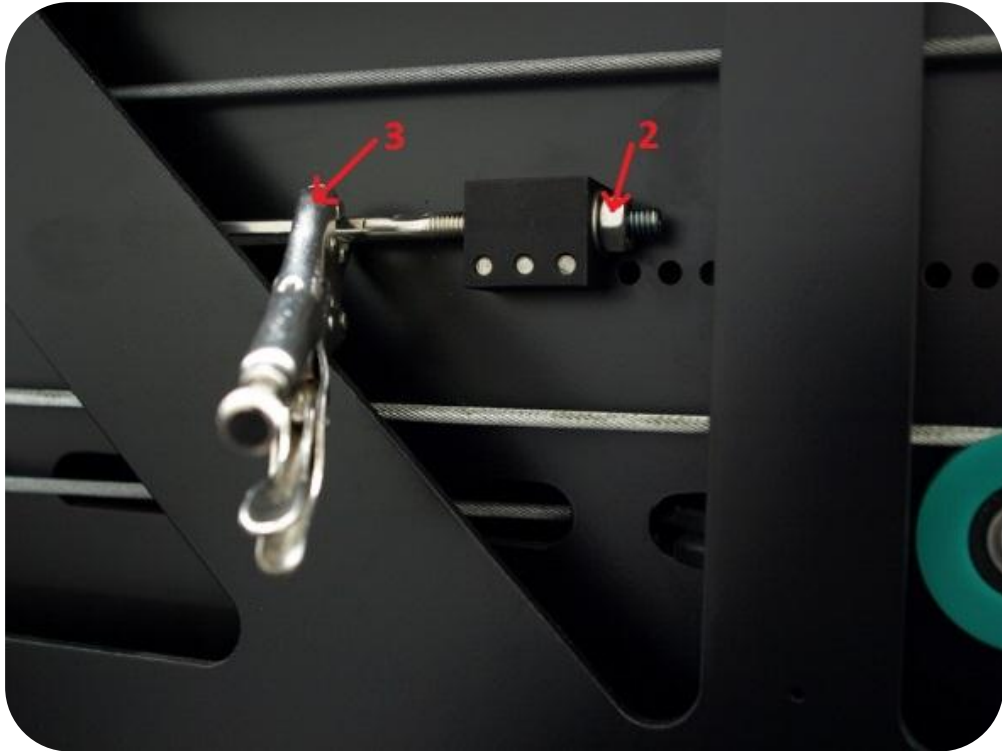

- 2.** Using this nut tension the cable.
- 3.** Hold the cable to prevent it from rotating

A.5. Upper green belt tensioning.

Properly tensioned upper belt cannot touch the section when the crane is fully loaded and shorten to maximum at maximum angle.

It is forbidden to use screw on the back of the crane to tension the belt.

To tension the upper belt use the screws in front of the belt under the cover.

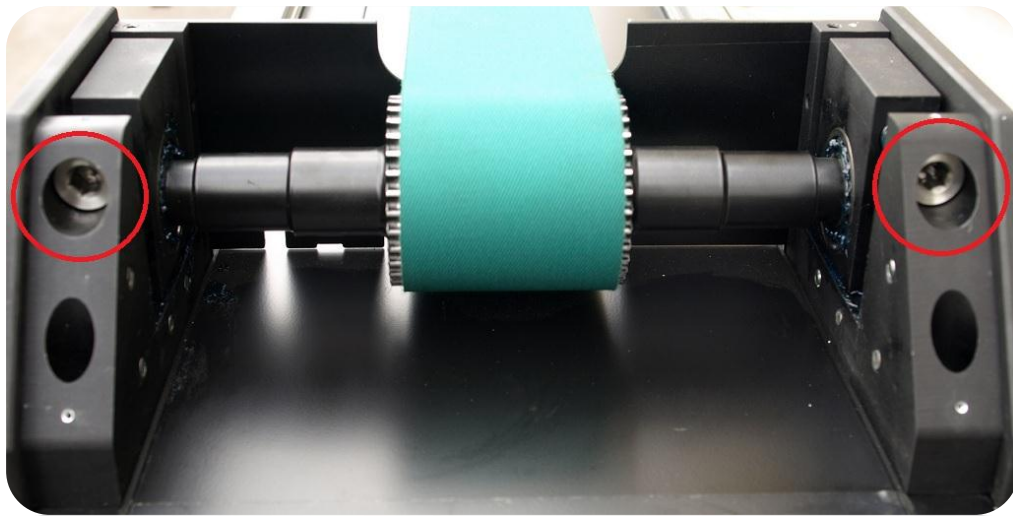

Strain the upper belt when the crane is fully loaded and shorten to maximum at maximum angle. In that position the belt is in its heaviest working conditions. The belt cannot slide on the section at that time.

Important! Use the adjustment screws on both sides of the axle to make the belt rotate in the center of the rack. Wrong tensioning may result in falling off the belt from the rack which can cause heavy damage to the crane and is very dangerous for the people nearby. MovieBird does not take any responsibility if someone did the tensioning wrongly.

A.6. How to detach/fasten the last section (35 mode).

MB35' has an option to make it shorter by last section. In order to do that you need to turn off the electronics and extract the arm manually until it reaches position shown at the picture below.

Within this hole in the covers, there's an oval screw which you need to release. To be sure that the screw will not fall into the insides of the crane you can use the tool set provided with the crane (picture here). After those steps – retract the last section and block it like it's shown at the picture below. To make the crane 45 feet long again just reattach the screw you released before.

Part 3

Electronics/Troubleshooting

Electronics

Full electronic equipment provided with the crane contains:

- Box
- AC for leveling head



- Leveling head



- Joystick



- Cables

- Wireless system (optional)



Troubleshooting

Symptom	Cause	Solution
After turning on the box, power switch neon is off and system not responds	Fuse blow up	Check fuse and power supply switches
LCD display shows "TERMINAL" after 5 sec from turning on the system	Joystick cable fault or interface electronics in joystick or main board is damaged	Check joystick cable, if cable is ok then check internal communication interface in joystick or main board
LCD display shows "READY" but the motor is not stable	Tachogenerator cable is damaged	Check crane cable, motor cable, brushes. If cable is ok then check connection between cannon connector and servo amplifier
LCD display shows "READY" but you can't move the crane with the joystick or manually	<ol style="list-style-type: none"> 1. Motor cable fault, security bridge is open, startup electronics is damaged 2. Proximity switches connection fault 	<ol style="list-style-type: none"> 1. Check motor cable if it's ok then check motor connections and security bridge connection and start up electronics 2. Check motor cable, if it's ok then check connections on the crane and internal electronics (both proximity switches are normally closed)
Crane doesn't stop on proximity switch	Proximity switches connection fault	Check motor cable, if it's ok then check both

			proximity switch, if you push them they're opened, if pushing doesn't have any effect then probably cable have short circuit or proximity switch is broken
LCD display shows "ERROR 01"	2.5V joystick cable is damaged		Check connection between speed potentiometer and joystick PCB
LCD display shows "ERROR 02"	GND joystick cable is damaged		Check connection between speed potentiometer and joystick PCB
LCD display shows "ERROR 03"	1.25V joystick cable is damaged		Check connection between speed potentiometer and joystick
LCD display shows "ERROR 04"	Speed joystick cable is damaged		Check connection between speed potentiometer and joystick PCB
LCD display shows "ERROR 05"	DAC range error		Check connection between security voltage check, if it's ok then you have to check internal DAC module
LCD display shows "ERROR 06"	DAC check wire fault		Check connection between security voltage check, if it's ok then check internal DAC module
LCD display shows "ERROR 07"	DAC feed error		Check connection between security voltage check, if it's ok then check internal DAC module
LCD display shows	Encoder ADCQAF		Check encoder QAF

"ERROR 08"		connection, check motor cable, crane cable and encoder
LCD display shows "ERROR 09"	Encoder ADCQBF	Check encoder QBF connection, check motor cable, crane cable and encoder
LCD display shows "ERROR 10"	Encoder XINT	Check encoder connection, check motor cable, crane cable and encoder
LCD display shows "ERROR 11"	Joystick stop	Turn off and turn on BOX. If this doesn't help then check joystick cable, if it's ok then check internal electronics
LCD display shows "EROR 12"	Servo inhibit fault	Check connections between main board and servo, if it's ok then check internal electronics on main board and check servo
LCD display shows "ERROR 13"	DAC Init error	Check connection between security voltage check, if it's ok then check internal DAC module
LCD display shows "ERROR 14"	Encoder Init error	Check connections between encoder and mainboard and supply of the encoder
Box give a six or seven beeps	Voltage error	Check all power supplies