

Atlas Copco Instruction Manual



Instruction Manual
for Portable Compressors
English

XATS 138 PE Stage V APP
XATS 250 PE Stage V APP
XAHS 108 PE Stage V APP
XAHS 190 PE Stage V APP

Engine
Kubota V2403-CR-T-E5B

Atlas Copco

**Instruction Manual
for Portable Compressors**

**XATS 138 PE Stage V APP
XATS 250 PE Stage V APP
XAHS 108 PE Stage V APP
XAHS 190 PE Stage V APP**

Original instructions

Printed matter No.
2960 5790 00

10/2021

The Atlas Copco logo consists of the brand name 'Atlas Copco' in a stylized, italicized serif font. It is positioned between two thick, solid black horizontal bars.

ATLAS COPCO - PORTABLE ENERGY DIVISION
www.atlascopco.com

Warranty and Liability Limitation

Use only authorized parts.

Any damage or malfunction caused by the use of unauthorized parts is not covered by Warranty or Product Liability.

The manufacturer does not accept any liability for any damage arising from modifications, additions or conversions made without the manufacturer's approval in writing.

Neglecting maintenance or making changes to the setup of the machine can result in major hazards, including fire risk.

While every effort has been made to ensure that the information in this manual is correct, Atlas Copco does not assume responsibility for possible errors.

Copyright 2021, www.atlascopco.com

Atlas Copco Airpower,

Boomssteenweg 957,

2610 Wilrijk,

Belgium.

Any unauthorized use or copying of the contents or any part thereof is prohibited.

This applies in particular to trademarks, model denominations, part numbers and drawings.

Preface

Follow the instructions in this booklet and we guarantee you years of troublefree operation. It is a solid, safe and reliable machine, built according to the latest technology.

Always keep the manual available near the machine.

In all correspondence always mention the compressor type and serial number, shown on the data plate.

The company reserves the right to make changes without prior notice.

Table of contents

1	Safety precautions	7
1.1	Personal protective equipment	7
1.2	7
1.3	Introduction	7
1.4	General safety precautions	8
1.5	Safety during transport and installation	9
1.6	Safety during use and operation	10
1.7	Safety during maintenance and repair	11
1.8	Tool applications safety	12
1.9	Specific safety precautions	13
2	Leading particulars	15
2.1	Safety pictograms used	15
2.2	General description	15
3	Main Parts	18
4	Overview	20
4.1	Markings and information labels	22
5	Operating instructions	23
5.1	Parking, towing and lifting instructions	23
5.1.1	Parking instructions	23
5.1.2	Towing instructions	24
5.1.3	Lifting instructions	26
5.2	Shipping the compressor	27
5.2.1	Fixation tools	28
5.2.2	Securing the unit to the shipping vehicle	29
5.3	Operating the compressor	30
5.3.1	Prevent low loads	30
5.3.2	Before starting	30

5.4	Starting/Stopping	31
5.5	Emergency stop	31
5.6	Basic operation of the machine	32
5.6.1	Control panel	32
5.6.2	Overview icons	34
5.6.3	Possible views	36
5.6.4	Starting	38
5.6.5	Pressure setting	42
5.6.6	During operation	43
5.6.7	Stopping	44
5.6.8	Shutdown	44
5.6.9	Power off	45
5.6.10	Settings	45
5.6.11	ECO mode	47
5.6.12	Fault codes	50
6	Maintenance	51
6.1	Storage	52
6.2	Fleetlink	52
6.3	Daily maintenance compressor before starting a job	52
6.4	Daily maintenance undercarriage before a roadgoing job	52
6.4.1	Compressor oil level check	58
6.4.2	Engine oil level check	59
6.5	Coolant	59
6.5.1	Coolant level check	59
6.6	Air filter engine/compressor	60
6.7	Cleaning coolers	60
6.8	Battery	60
6.8.1	Recharging a battery	60
6.8.2	Periodic battery service	60
6.9	Spillage-free frame	61

7	Available options	62
8	Problem solving	63
9	Technical specifications	65
9.1	Compressor / engine specifications	65
9.1.1	Reference conditions	65
9.1.2	Limitations	65
9.1.3	Performance Data (3) (4)	66
9.1.4	Design data	67
9.2	Altitude unit performance curves	69
10	Dimension drawing	70
11	Electrical diagram	74
12	Dataplate	81
13	Disposal	82
14	Maintenance Log	83

Safety precautions

PERSONAL PROTECTIVE EQUIPMENT



 To be read attentively and acted accordingly before towing, lifting, operating, performing maintenance or repairing the unit.

INTRODUCTION

The policy of Atlas Copco is to provide the users of their equipment with safe, reliable and efficient products. Factors taken into account are among others:

- the intended and predictable future use of the products, and the environments in which they are expected to operate,
- applicable rules, codes and regulations,
- the expected useful product life, assuming proper service and maintenance,
- providing the manual with up-to-date information.

Before handling any product, take time to read the relevant instruction manual. Besides giving detailed operating instructions, it also gives specific information about safety, preventive maintenance, etc.

Always keep the manual near the unit so that operating personnel can easily access.

See also the safety precautions of the engine and possible other equipment, which are separately sent along or are mentioned on the equipment or parts of

the unit.

These safety precautions are general and some statements will therefore not always apply to a particular unit.

Only people that have the right skills should be allowed to operate, adjust, perform maintenance or repair on Atlas Copco equipment.

It is the responsibility of management to appoint operators with the appropriate training and skill for each category of job.

Skill level 1: Operator

An operator is trained in all aspects of operating the unit with the push-buttons, and is trained to know the safety aspects.

Skill level 2: Mechanical technician

A mechanical technician is trained to operate the unit the same as the operator. In addition, the mechanical technician is also trained to perform maintenance and repair, as described in the instruction manual, and is allowed to change settings of the control and safety system. A mechanical technician does not work on live electrical components.

Skill level 3: Electrical technician

An electrical technician is trained and has the same qualifications as both the operator and the mechanical technician. In addition, the electrical technician may carry out electrical repairs within the various enclosures of the unit. This includes work on live electrical components.

Skill level 4: Specialist from the manufacturer

This is a skilled specialist sent by the manufacturer or its agent to perform complex repairs or modifications to the equipment.

In general it is recommended that not more than two people operate the unit, more operators could lead to unsafe operating conditions.

Take necessary steps to keep unauthorized persons away from the unit and eliminate all possible sources of danger at the unit.

When handling, operating, overhauling and/or performing maintenance or repair on Atlas Copco equipment, the mechanics are expected to use safe engineering practices and to observe all relevant local safety requirements and ordinances. The following list is a reminder of special safety directives and

precautions mainly applicable to Atlas Copco equipment.

These safety precautions apply to machinery processing or consuming air. Processing of any other gas requires additional safety precautions typical to the application and are not included herein.

Neglecting the safety precautions may endanger people as well as environment and machinery:

- endanger people due to electrical, mechanical or chemical influences,
- endanger the environment due to leakage of oil, solvents or other substances,
- endanger the machinery due to function failures.

All responsibility for any damage or injury resulting from neglecting these precautions or by non-observance of ordinary caution and due care required in handling, operating, maintenance or repair, also if not expressly mentioned in this instruction manual, is disclaimed by Atlas Copco.

The manufacturer does not accept any liability for any damage arising from the use of non-original parts and for modifications, additions or conversions made without the manufacturer's approval in writing.

If any statement in this manual does not comply with local legislation, the stricter of the two shall be applied.

Statements in these safety precautions should not be interpreted as suggestions, recommendations or inducements that it should be used in violation of any applicable laws or regulations.

GENERAL SAFETY PRECAUTIONS

- 1 The owner is responsible for maintaining the unit in a safe operating condition. Unit parts and accessories must be replaced if missing or unsuitable for safe operation.
- 2 The supervisor, or the responsible person, shall at all times make sure that all instructions regarding machinery and equipment operation and maintenance are strictly followed and that the machines with all accessories and safety devices, as well as the consuming devices, are in good repair, free of abnormal wear or abuse, and are not tampered with.
- 3 Whenever there is an indication or any suspicion that an internal part of a machine is overheated, the machine shall be stopped but no inspection covers shall be opened before sufficient cooling time has elapsed; this to avoid the risk of spontaneous ignition of oil vapour when air is admitted.
- 4 Normal ratings (pressures, temperatures, speeds, etc.) shall be durably marked.
- 5 Operate the unit only for the intended purpose and within its rated limits (pressure, temperature, speeds, etc.).
- 6 The machinery and equipment shall be kept clean, i.e. as free as possible from oil, dust or other deposits.
- 7 To prevent an increase in working temperature, inspect and clean heat transfer surfaces (cooler fins, intercoolers, water jackets, etc.) regularly.
- 8 All regulating and safety devices shall be maintained with due care to ensure that they function properly. They may not be put out of action.
- 9 Care shall be taken to avoid damage to safety valves and other pressure-relief devices, especially to avoid plugging by paint, oil coke or dirt accumulation, which could interfere with the functioning of the device.
- 10 Pressure and temperature gauges shall be checked regularly with regard to their accuracy. They shall be replaced whenever outside acceptable tolerances.
- 11 Safety devices shall be tested as described in the maintenance schedule of the instruction manual to determine that they are in good operating condition.
- 12 Mind the markings and information labels on the unit.
- 13 In the event the safety labels are damaged or destroyed, they must be replaced to ensure operator safety.
- 14 Keep the work area neat. Lack of order will increase the risk of accidents.
- 15 When working on the unit, wear safety clothing. Depending on the kind of activities these are: safety glasses, ear protection, safety helmet (including visor), safety gloves, protective clothing, safety shoes. Do not wear the hair long and loose (protect long hair with a hairnet), or wear loose clothing or jewellery.
- 16 Take precautions against fire. Handle fuel, oil and anti-freeze with care because they are inflammable substances. Do not smoke or approach with naked flame when handling such substances. Keep a fire-extinguisher in the vicinity.

SAFETY DURING TRANSPORT AND INSTALLATION

Transport of the unit has to be done by authorized/experienced people.

When towing, lifting or transporting the compressor in any way, the battery switch must always be switched off.

To lift a unit, all loose or pivoting parts, e.g. doors and tow bar, shall first be securely fastened.

Do not attach cables, chains or ropes directly to the lifting eye; apply a crane hook or lifting shackle meeting local safety regulations. Never allow sharp bends in lifting cables, chains or ropes.

Helicopter lifting is not allowed.

It is strictly forbidden to dwell or stay in the risk zone under a lifted load. Never lift the unit over people or residential areas. Lifting acceleration and retardation shall be kept within safe limits.

1 Before towing the unit:

- ascertain that the pressure vessel(s) is (are) depressurized,
- check the towbar, the brake system and the towing eye. Also check the coupling of the towing vehicle,
- check the towing and brake capability of the towing vehicle,
- check that the towbar, jockey wheel or stand leg is safely locked in the raised position. See **Markings and information labels**, for relevant warning,
- keep hands/fingers away from the coupling device and all other potential pinch points. Keep feet away from the towbar to avoid injury if it should slip,
- ascertain that the towing eye can swivel freely

- on the hook,
 - check that the wheels are secure and that the tyres are in good condition and inflated correctly,
 - connect the signalisation cable, check all lights and ascertain that the signalisation cable can not drag on the ground when towing the unit,
 - attach the safety break-away cable or safety chain to the towing vehicle,
 - remove wheel chocks, if applied, and disengage the parking brake,
 - check whether springs on wheel chocks are missing or broken.
- 2 To tow a unit use a towing vehicle of ample capacity. Refer to the documentation of the towing vehicle.
 - 3 If the unit is to be backed up by the towing vehicle, disengage the overrun brake mechanism (if it is not an automatic mechanism).
 - 4 Never exceed the maximum towing speed of the unit (mind the local regulations).
 - 5 Place the unit on level ground and apply the parking brake before disconnecting the unit from the towing vehicle. Unclip the safety break-away cable or safety chain. If the unit has no parking brake or jockey wheel, immobilize the unit by placing chocks in front of and/or behind the wheels. When the towbar can be positioned vertically, the locking device must be applied and kept in good order. The unit must always be used/parked/stored in a non publicly accessible area, locked away from access by unauthorized persons.
 - 6 To lift heavy parts, a hoist of ample capacity, tested and approved according to local safety regulations, shall be used.

- 7 Lifting hooks, eyes, shackles, etc., shall never be bent and shall only have stress in line with their design load axis. The capacity of a lifting device diminishes when the lifting force is applied at an angle to its load axis.
- 8 For maximum safety and efficiency of the lifting apparatus all lifting members shall be applied as near to perpendicular as possible. If required, a lifting beam shall be applied between hoist and load.
- 9 Never leave a load hanging on a hoist.
- 10 A hoist has to be installed in such a way that the object will be lifted perpendicular. If that is not possible, the necessary precautions must be taken to prevent load-swinging, e.g. by using two hoists, each at approximately the same angle not exceeding 30° from the vertical.
- 11 Locate the unit away from walls. Take all precautions to ensure that hot air exhausted from the engine and driven machine cooling systems cannot be recirculated. If such hot air is taken in by the engine or driven machine cooling fan, this may cause overheating of the unit; if taken in for combustion, the engine power will be reduced.
- 12 Before moving the compressor, switch it off.

SAFETY DURING USE AND OPERATION

- 1 When the unit has to operate in a fire-hazardous environment, each engine exhaust has to be provided with a spark arrestor to trap incendiary sparks.
- 2 The exhaust contains carbon monoxide which is a lethal gas. When the unit is used in a confined space, conduct the engine exhaust to the outside atmosphere by a pipe of sufficient diameter; do this in such a way that no extra back pressure is created for the engine. If necessary, install an extractor. Observe any existing local regulations. Make sure that the unit has sufficient air intake for operation. If necessary, install extra air intake ducts.
- 3 When operating in a dust-laden atmosphere, place the unit so that dust is not carried towards it by the wind. Operation in clean surroundings considerably extends the intervals for cleaning the air intake filters and the cores of the coolers.
- 4 Close the compressor air outlet valve before connecting or disconnecting a hose. Ascertain that a hose is fully depressurized before disconnecting it. Before blowing compressed air through a hose or air line, ensure that the open end is held securely, so that it cannot whip and cause injury.
- 5 The air line end connected to the outlet valve must be safeguarded with a safety cable, attached next to the valve.
- 6 No external force may be exerted on the air outlet valves, e.g. by pulling on hoses or by installing auxiliary equipment directly to a valve, e.g. a water separator, a lubricator, etc. Do not step on the air outlet valves.
- 7 Never move a unit when external lines or hoses are connected to the outlet valves, to avoid damage to valves, manifold and hoses.
- 8 Do not use compressed air from any type of compressor, without taking extra measures, for breathing purposes as this may result in injury or death. For breathing air quality, the compressed air must be adequately purified according to local legislation and standards. Breathing air must always be supplied at stable, suitable pressure.
- 9 Distribution pipework and air hoses must be of correct diameter and suitable for the working pressure. Never use frayed, damaged or deteriorated hoses. Replace hoses and flexibles before the lifetime expires. Use only the correct type and size of hose end fittings and connections.
- 10 If the compressor is to be used for sand-blasting or will be connected to a common compressed-air system, fit an appropriate non-return valve (check valve) between compressor outlet and the connected sand-blasting or compressed-air system. Observe the right mounting position/direction.
- 11 Before removing the oil filler plug, ensure that the pressure is released by opening an air outlet valve.
- 12 Never remove a filler cap of the cooling water system of a hot engine. Wait until the engine has sufficiently cooled down.
- 13 Never refill fuel while the unit is running, unless otherwise stated in the Atlas Copco instruction book. Keep fuel away from hot parts such as air outlet pipes or the engine exhaust. Do not smoke when fuelling. When fuelling from an automatic pump, an earthing cable should be connected to the unit to discharge static electricity. Never spill nor leave oil, fuel, coolant or cleansing agent in or around the unit.
- 14 All doors shall be shut during operation so as not to disturb the cooling air flow inside the bodywork and/or render the silencing less effective. A door should be kept open for a short period only e.g. for inspection or adjustment.
- 15 Periodically carry out maintenance works according to the maintenance schedule.
- 16 Stationary housing guards are provided on all rotating or reciprocating parts not otherwise protected and which may be hazardous to personnel. Machinery shall never be put into operation, when such guards have been removed, before the guards are securely reinstalled.
- 17 Noise, even at reasonable levels, can cause irritation and disturbance which, over a long period of time, may cause severe injuries to the nervous system of human beings. When the sound pressure level, at any point where personnel normally has to attend, is:
 - below 70 dB(A): no action needs to be taken,
 - above 70 dB(A): noise-protective devices should be provided for people continuously being present in the room,
 - below 85 dB(A): no action needs to be taken for occasional visitors staying a limited time only,
 - above 85 dB(A): room to be classified as a noise-hazardous area and an obvious warning shall be placed permanently at each entrance to alert people entering the room, for even relatively short times, about the need to wear ear protectors,
 - above 95 dB(A): the warning(s) at the entrance(s) shall be completed with the recommendation that also occasional visitors shall wear ear protectors,
 - above 105 dB(A): special ear protectors that are adequate for this noise level and the spectral composition of the noise shall be provided and a special warning to that effect shall be placed at each entrance.

- 18 The unit has parts, which may be accidentally touched by personal, of which the temperature can be in excess of 80°C (176°F). The insulation or safety guard, protecting these parts shall not be removed before the parts have cooled down to room temperature. As it is technically not possible to insulate all hot parts or to install safety guards around hot parts (e.g. exhaust manifold, exhaust turbine), the operator / service engineer must always be aware not to touch hot parts when opening a machine door.
- 19 Never operate the unit in surroundings where there is a possibility of taking in flammable or toxic fumes.
- 20 If the working process produces fumes, dust or vibration hazards, etc., take the necessary steps to eliminate the risk of personal injury.
- 21 When using compressed air or inert gas to clean down equipment, do so with caution and use the appropriate protection, at least safety glasses, for the operator as well as for any bystander. Do not apply compressed air or inert gas to your skin or direct an air or gas stream at people. Never use it to clean dirt from your clothes.
- 22 When washing parts in or with a cleaning solvent, provide the required ventilation and use appropriate protection such as a breathing filter, safety glasses, rubber apron and gloves, etc.
- 23 Safety shoes should be compulsory in any workshop and if there is a risk, however small, of falling objects, wearing of a safety helmet should be included.
- 24 If there is a risk of inhaling hazardous gases, fumes or dust, the respiratory organs must be protected and depending on the nature of the hazard, so must the eyes and skin.
- 25 Remember that where there is visible dust, the finer, invisible particles will almost certainly be present too; but the fact that no dust can be seen is not a reliable indication that dangerous, invisible dust is not present in the air.
- 26 Never operate the unit at pressures or speeds below or in excess of its limits as indicated in the technical specifications.
- 27 Do not use aerosol types of starting aids such as ether. Such use could result in an explosion and personal injury.

SAFETY DURING MAINTENANCE AND REPAIR

Maintenance, overhaul and repair work shall only be carried out by adequately trained personnel; if required, under supervision of someone qualified for the job.

- 1 Use only the correct tools for maintenance and repair work, and only tools which are in good condition.
- 2 Parts shall only be replaced by genuine Atlas Copco replacement parts.
- 3 All maintenance work, other than routine attention, shall only be undertaken when the unit is stopped. Steps shall be taken to prevent inadvertent starting. In addition, a warning sign bearing a legend such as "work in progress; do not start" shall be attached to the starting equipment. On engine-driven units the battery shall be disconnected and removed or the terminals covered by insulating caps. On electrically driven units the main switch shall be locked in open position and the fuses shall be taken out. A warning sign bearing a legend such as "work in progress; do not supply voltage" shall be attached to the fuse box or main switch.
- 4 Before dismantling any pressurized component, the compressor or equipment shall be effectively isolated from all sources of pressure and the entire system shall be relieved of pressure. Do not rely on non-return valves (check valves) to isolate pressure systems. In addition, a warning sign bearing a legend such as "work in progress; do not open" shall be attached to each of the outlet valves.
- 5 Prior to stripping an engine or other machine or undertaking major overhaul on it, prevent all movable parts from rolling over or moving.

- 6 Make sure that no tools, loose parts or rags are left in or on the machine. Never leave rags or loose clothing near the engine air intake.
- 7 Never use flammable solvents for cleaning (fire-risk).
- 8 Take safety precautions against toxic vapours of cleaning liquids.
- 9 Never use machine parts as a climbing aid.
- 10 Observe scrupulous cleanliness during maintenance and repair. Keep away dirt, cover the parts and exposed openings with a clean cloth, paper or tape.
- 11 Never weld on or perform any operation involving heat near the fuel or oil systems. Fuel and oil tanks must be completely purged, e.g. by steam-cleaning, before carrying out such operations. Never weld on, or in any way modify, pressure vessels. Disconnect the alternator cables during arc welding on the unit.
- 12 Support the towbar and the axle(s) securely if working underneath the unit or when removing a wheel. Do not rely on jacks.
- 13 Do not remove any of, or tamper with, the sound-damping material. Keep the material free of dirt and liquids such as fuel, oil and cleansing agents. If any sound-damping material is damaged, replace it to prevent the sound pressure level from increasing.
- 14 Use only lubricating oils and greases recommended or approved by Atlas Copco or the machine manufacturer. Ascertain that the selected lubricants comply with all applicable safety regulations, especially with regard to explosion or fire-risk and the possibility of decomposition or generation of hazardous gases. Never mix synthetic with mineral oil.
- 15 Protect the engine, alternator, air intake filter, electrical and regulating components, etc., to prevent moisture ingress, e.g. when steam-cleaning.
- 16 When performing any operation involving heat, flames or sparks on a machine, the surrounding components shall first be screened with non-flammable material.
- 17 Never use a light source with open flame for inspecting the interior of a machine.
- 18 Disconnect battery clamp before starting electrical servicing or welding (or turn battery switch in "off" position).
- 19 When repair has been completed, the machine shall be barred over at least one revolution for reciprocating machines, several revolutions for rotary ones to ensure that there is no mechanical interference within the machine or driver. Check the direction of rotation of electric motors when starting up the machine initially and after any alteration to the electrical connection(s) or switch gear, to check that the oil pump and the fan function properly.
- 20 Maintenance and repair work should be recorded in an operator's logbook for all machinery. Frequency and nature of repairs can reveal unsafe conditions.
- 21 When hot parts have to be handled, e.g. shrink fitting, special heat-resistant gloves shall be used and, if required, other body protection shall be applied.
- 22 When using cartridge type breathing filter equipment, ascertain that the correct type of cartridge is used and that its useful service life is not surpassed.
- 23 Make sure that oil, solvents and other substances likely to pollute the environment are properly disposed of.
- 24 Before clearing the unit for use after maintenance or overhaul, check that operating pressures, temperatures and speeds are correct and that the control and shutdown devices function correctly.

TOOL APPLICATIONS SAFETY



Check the maximum pressure of the tool and hoses against maximum vessel pressure.

Apply the proper tool for each job. With the knowledge of correct tool use and knowing the limitations of tools, along with some common sense, many accidents can be prevented.

Special service tools are available for specific jobs and should be used when recommended. The use of these tools will save time and prevent damage to parts.

SPECIFIC SAFETY PRECAUTIONS

Batteries

When servicing batteries, always wear protecting clothing and glasses.

- 1 The electrolyte in batteries is a sulphuric acid solution which is fatal if it hits your eyes, and which can cause burns if it contacts your skin. Therefore, be careful when handling batteries, e.g. when checking the charge condition.
- 2 Install a sign prohibiting fire, open flame and smoking at the post where batteries are being charged.
- 3 When batteries are being charged, an explosive gas mixture forms in the cells and might escape through the vent holes in the plugs. Thus an explosive atmosphere may form around the battery if ventilation is poor, and can remain in and around the battery for several hours after it has been charged. Therefore:
 - never smoke near batteries being, or having recently been, charged,
 - never break live circuits at battery terminals, because a spark usually occurs.
- 4 When connecting an auxiliary battery (AB) in parallel to the unit battery (CB) with booster cables: connect the + pole of AB to the + pole of CB, then connect the – pole of CB to the mass of the unit. Disconnect in the reverse order.
- 5 Overfilling the battery can cause loss of electrolyte while gassing and reduce the concentration of acid in the electrolyte. This will lead to reduced battery performance over time. Overfilling the battery can also lead to acid burns as the battery can spit electrolyte while gassing.
- 6 Once the battery has been charged, ensure that the battery is unplugged before disconnecting the

charging terminals. If the battery charging terminals are disconnected before unplugging the battery, it will lead to sparking, which can ignite the gases expelled during the charging process.

- 7 To prevent sparking and a possible ignition of battery gases, always connect the positive terminal clamp before connecting the negative terminal clamp.
- 8 Shorting the battery terminals with wires or metal contacts can cause irreversible damage. It can result in melted terminals, affect the charging efficiency of the battery, render it useless or lead to an explosion.
- 9 Cranking the engine when the battery is heavily discharged can lead to sparking which can result in an explosion.

Pressure vessels

Maintenance/installation requirements:

- 1 The vessel can be used as pressure vessel or as separator and is designed to hold compressed air for the following application:
 - pressure vessel for compressor,
 - medium AIR/OIL,and operates as detailed on the data plate of the vessel:
 - the maximum working pressure ps in bar (psi),
 - the maximum working temperature Tmax in °C (°F),
 - the minimum working temperature Tmin in °C (°F),
 - the capacity of the vessel V in l (US gal).
- 2 The pressure vessel is only to be used for the applications as specified above and in accordance with the technical specifications. Safety reasons prohibit any other applications.
- 3 National legislation requirements with respect to re-inspection must be complied with.
- 4 No welding or heat treatment of any kind is permitted to those vessel walls which are exposed to pressure.
- 5 The vessel is provided and may only be used with the required safety equipment such as manometer, overpressure control devices, safety valve, etc.
- 6 Draining of condensate shall be performed daily when vessel is in use.
- 7 Installation, design and connections should not be changed.
- 8 Bolts of cover and flanges may not be used for extra fixation.
- 9 (Pressure) vessel maintenance is to be performed by Atlas Copco.

Safety valves

- 1 All adjustments or repairs are to be done by an authorized representative of the valve supplier.
- 2 Only trained and technically competent personnel should consider overhaul, re-set or performance testing of safety valves.
- 3 The safety valve is supplied with either a lead security seal or crimped cover to deter unauthorised access to the pressure regulation device.
- 4 Under no circumstances should the set pressure of the safety valve be altered to a different pressure than that stamped on the valve without the permission of the installation designer.
- 5 If the set pressure must be altered then use only correct parts supplied by Atlas Copco and in accordance with the instructions available for the valve type.
- 6 Safety valves must be frequently tested and regularly maintained.
- 7 The set pressure should be periodically checked for accuracy.
- 8 When fitted, the compressors should be operated at pressures not less than 75% of the set pressure to ensure free and easy movement of internal parts.
- 9 The frequency of tests is influenced by factors such as the severity of the operating environment and aggressiveness of the pressurised medium.
- 10 Soft seals and springs should be replaced as part of the maintenance procedure.
- 11 Do not paint or coat the installed safety valve.

Selective catalytic reduction

The SCR catalytic converter contains vanadium pentoxide, a chemical known to the State of California to cause cancer.

The SCR catalytic converter is fitted in the silencer and does not constitute a health hazard during normal use and handling.

When carrying out work on the SCR catalytic converter which may result in exposure to dust, safety precautions must be taken. Such work includes, for example, opening the silencer machining and scrapping the SCR catalytic converter.

Safety precautions when working on the SCR system

- Inhalation: If dust is inhaled, the person should be provided with fresh air immediately. Seek medical attention.
- Eye contact: Rinse eyes with water immediately. If irritation persists, seek medical attention.
- Skin contact: Wash with water and soap. Remove contaminated clothes.
- Ingestion: If large amounts have been ingested, drink plenty of water and induce vomiting. Seek medical attention.

Environmental hazards

- Vanadium pentoxide is toxic to water organisms and can cause detrimental long term effects to water environment.

Leading particulars

SAFETY PICTOGRAMS USED



This symbol draws your attention to dangerous situations. The operation concerned may endanger persons and cause injuries.



This symbol is followed by supplementary information.

GENERAL DESCRIPTION

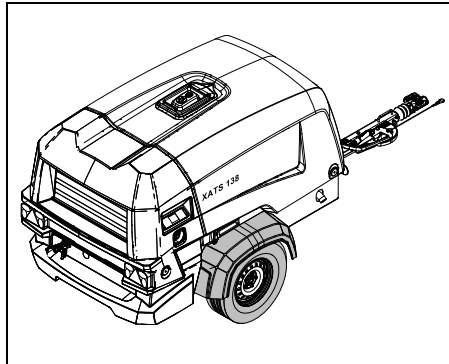

The compressors XATS 138 PE, XATS 250 PE, XAHS 108 PE and XAHS 190 PE are silenced, single-stage, oil-injected screw compressor, built for a nominal effective working pressure of 10.3 bar(g) (149.4 psi) or 12.0 bar(g) (174.0 psi) (see chapter **Technical specifications**).

The canopy has openings at the shaped front and rear end for the intake and outlet of cooling air. The canopy is internally lined with sound-absorbing material.

Engine

The compressor is driven by a liquid-cooled diesel engine.

The engine's power is transmitted to the compressor through a gear box.

To meet the demands of Stage V Emission Legislation, the engine is equipped with a diesel oxidation catalyst, a diesel particulate filter, and a selective catalytic reduction system. The particulate filter is standard certified as spark arrestor.

Compressor element

The compressor casing houses two screw-type rotors, mounted on ball and roller bearings. The male rotor, driven by the engine, drives the female rotor. The element delivers pulsation-free air.

Injected oil is used for sealing, cooling and lubricating purposes.

Compressor oil system

The oil is boosted by air pressure. The system has no oil pump.

The entire oil system is equipped with screwed oil hoses to ensure higher quality and less failures.

The oil is removed from the air, in the air/oil vessel first by centrifugal force, secondly by the oil separator element. A spin-on oil separator assures for quick service.

Regulation

The compressor is provided with a continuous regulating system and a blow-down valve which is integrated in the unloader assembly. The valve is closed during operation by outlet pressure of the compressor element and opens by air receiver pressure when the compressor is stopped.

When the air consumption increases, the air receiver pressure will decrease and vice versa.

This receiver pressure variation is sensed by the regulating valve which, by means of control air to the unloader and engine speed regulator, matches the air output to the air consumption. The air receiver pressure is maintained between the pre-selected working pressure and the corresponding unloading pressure.

Cooling system

The engine is provided with a liquid cooler and the compressor is provided with an oil cooler.

The top tank of the engine cooler is integrated in the cooler to reduce the amount of connections. This results in higher general robustness and less engine failures.

The cooling air is generated by a fan, driven by the engine.

Fuel system

The fuel feed lines and fuel filtration are designed in such a way that after running the fuel tank dry, air pockets can't reach the engine and smooth starting is ensured.

Safety devices

A thermal shut-down switch protects the compressor against overheating. The air receiver is provided with a safety valve.

The engine is equipped with low oil pressure and high coolant temperature shut-down switches.

Frame and axles

The machine is equipped with a spillage-free frame.

The base frame which is made out of a single metal sheet, can contain up to 110% of all the liquids in the compressor. A drain plug is installed to drain the frame and safely capture all the spilled liquids.

The bumper is designed in such a way that it protects the rear bottom of the frame if the machine would be tilted on its rear.

The compressor/engine unit is supported by rubber buffers in the frame.

The unit can be delivered with or without wheels. If equipped with wheels it has an adjustable or fixed tow bar with brakes. The tow bar can be equipped with a ball coupling or various towing eyes.

The tow bar can be equipped with a jockey wheel or support leg.

Lifting eye

A lifting eye is accessible through a rubber covered hole at the top of the unit.

Road light system (option)

The right hand traffic road light system includes rear lights, stop lights, direction indicators, license plate light, fog light and rear reflector and a 7-pin connector to connect the lights to the towing vehicle. The entire installation is EU type approved.

Wheel chocks are included when ordering the road light system.

Lubricator

A tool lubricator is a reservoir that can keep 2.4 l of lubricant. The lubricant is picked up by the outgoing air and delivered to the pneumatic tool on the other end of the air hose.

Data plate

The compressor is furnished with a data plate (D) showing the product code, the unit number and the working pressure (see chapter **Dataplate**).

VIN number

The VIN number is located on the right-hand front side of the frame.

Main Parts

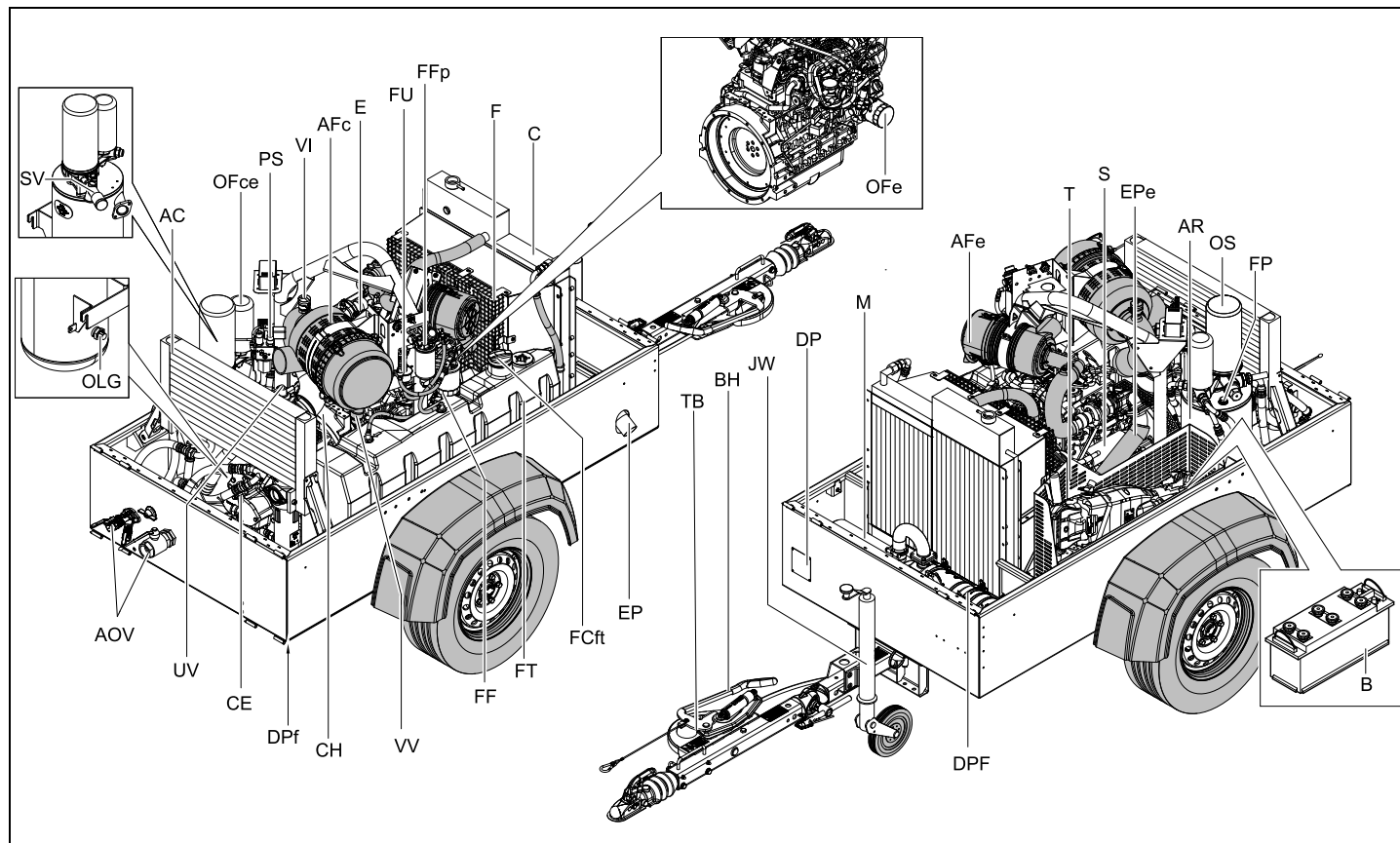

Reference	Name
AC	Aftercooler
AFc	Air Filter (compressor)
AFe	Air Filter (engine)
AR	Air Receiver
AOV	Air Outlet Valves
B	Battery
BH	Brake Handle
C	Cooler
CE	Compressor Element
CH	Coupling Housing
DP	Data Plate
DPf	Drain Plug (frame)
DPF	Diesel Particulate Filter
E	Engine
EP	Exhaust Pipe
EPe	Exhaust Pipe (engine)
F	Fan
FCft	Filler Cap (fuel tank)
FF	Fuel Filter
FFp	Fuel pre filter
FP	Filler Plug
FT	Fuel Tank
FU	Fuel Pump
JW	Jockey Wheel
M	Muffler

Reference	Name
OFce	Oil Filter (compressor element)
OFe	Oil Filter (engine)
OLG	Oil Level Gauge
OS	Oil Separator
PS	Pressure Sensor
S	Starting Motor
SV	Safety Valve
TB	Towbar
T	Tool Box
UV	Unloader Valve
VI	Vaccum Indicator
VV	Vacuator Valve



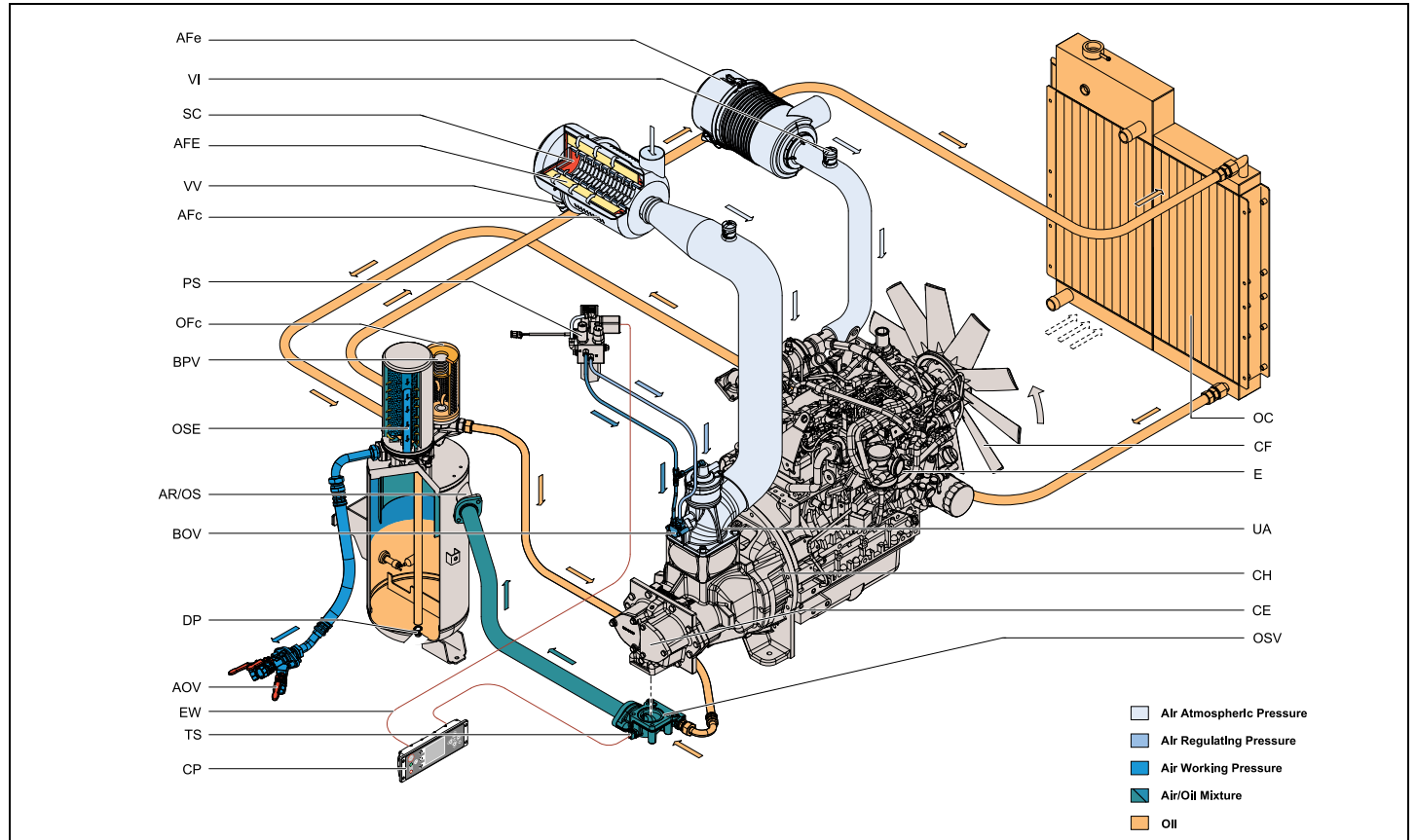







Overview





















Reference	Name
AFe	Air Filter (engine)
AFE	Air Filter Element
AFc	Air Filter (compressor)
AOV	Air Outlet Valve
AR/OS	Air Receiver/Oil Separator
BPV	By Pass Valve (oil filter)
BOV	Blow Off Valve
CE	Compressor Element
CF	Cooling Fan
CH	Coupling Housing
CP	Control Panel
DP	Drain Plug
E	Engine
EW	Electrical Wiring
OC	Oil Cooler
OFc	Oil Filter (compressor)
OSE	Oil Separator Element
OSV	Oil Stop Valve
PS	Pressure Sensor
SC	Safety Cartridge
TS	Temperature Switch
UA	Unloaded Assembly
VI	Vacuum Indicator (engine)
VV	Vacuator Valve

MARKINGS AND INFORMATION LABELS

For location of the labels refer to the spare parts manual.

	Danger, outlet gases.
	Danger, hot surface.
	Electrocution hazard.
 PAROIL M Xtreme	Atlas Copco mineral compressor oil.
 PAROIL S	Atlas Copco synthetic compressor oil.
 PAROIL Extra	Atlas Copco synthetic engine oil.
 PAROIL E Mission Green	Atlas Copco low sulphur engine oil.
	Manual.
	Read the instruction manual before working on the battery.
	On / off button.
	Hours, time.

	Prohibition to open air valves without connected hoses.
	Airfilter.
	Compressor temperature too high.
	Rotation direction.
	Read the instruction manual before starting.
	Service every 24 hours.
	Warning! Part under pressure.
	Do not stand on outlet valves.
	Do not run the compressor with open doors.
	Lifting device.
	Use diesel fuel only.

	Tyre pressure.
	Service.
	Engine coolant.
	Sound power level in accordance with Directive 2000/14/EC (expressed in dB (A)).
	Horizontal towbar position required in case of coupling.
	Flammable substances.
	Do not tow with the support in rest position.
	Check the maximum pressure of the tool and hoses against maximum vessel pressure.

Operating instructions

PARKING, TOWING AND LIFTING INSTRUCTIONS

Safety precautions



The operator is expected to apply all relevant **Safety precautions**.

Attention



After the first 100 km travel:

Check and retighten the wheel nuts and towbar bolts to the specified torque. See section **Technical specifications**.



When using a towing vehicle to manoeuvre the unit, take care that the support leg is lifted maximally.

When the jockey wheel is on the ground, the unit may only be manoeuvred by hand.

PARKING INSTRUCTIONS

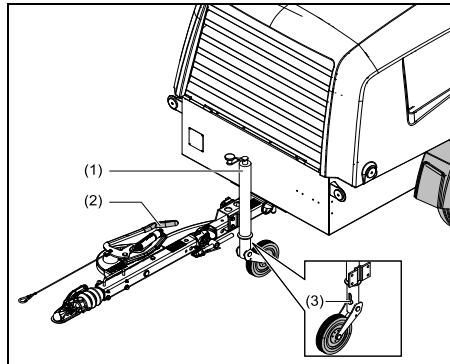

When parking a compressor, secure support leg or jockey wheel (1) to support the compressor in a level position. Be sure that the jockey wheel (1) is blocked by the blocking pin (3).

Apply parking brake by pulling parking brake handle (2) upwards, towards towing eye. Place the compressor as level as possible; however, it can be operated temporarily in an out of level position not exceeding 15°. If the compressor is parked on sloping ground, immobilize the compressor by placing wheel chocks in front of or behind the wheels.

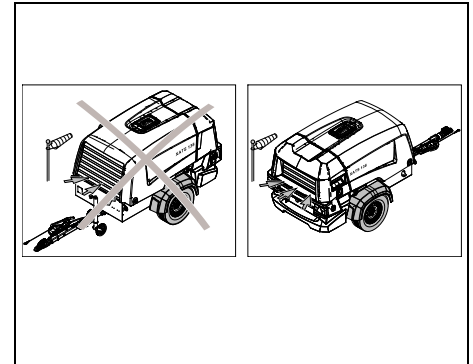

Locate the rear-end of the compressor upwind, away from contaminated wind-streams and walls. Avoid recirculation of exhaust gas and warmed-up cooling air. This causes overheating and engine power decrease. Do not obstruct air evacuation from the cooling system. The compressor oil lifetime will be shortened when the compressor inlet air is contaminated.

TOWING INSTRUCTIONS

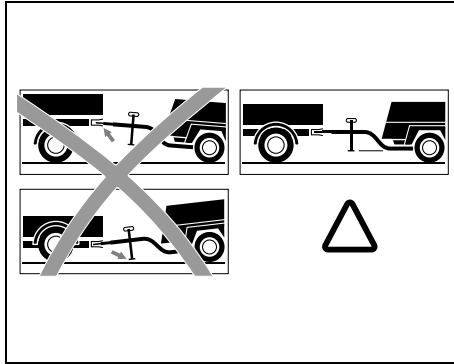

Label on towbar, towing instructions

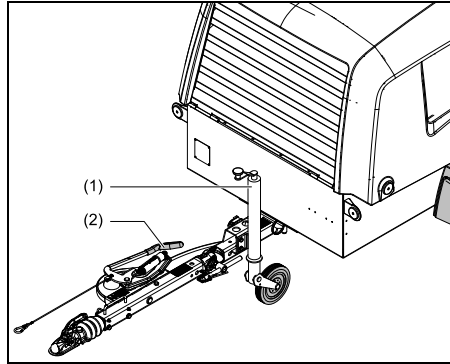

Adjustable towbar with jockey wheel and brakes

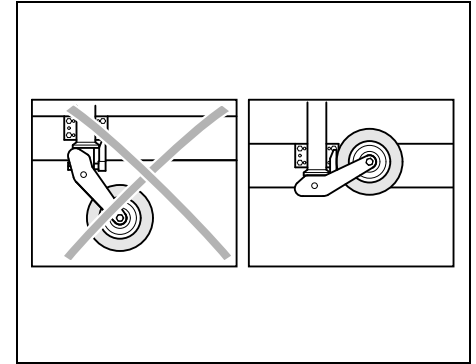

Towing position of jockey wheel



Before towing the compressor, ensure that the towing equipment of the vehicle matches the towing eye or ball connector, and ensure that the hood is closed and locked properly.

For both non-adjustable and adjustable towbar, the towbar should be as level as possible and the compressor and towing eye end in a level position.

Push the hand brake lever (2) completely downwards, away from towing eye and connect breakaway cable to the vehicle. Secure jockey wheel (1) or support leg in the highest possible position.

HEIGHT ADJUSTMENT (with adjustable towbar)

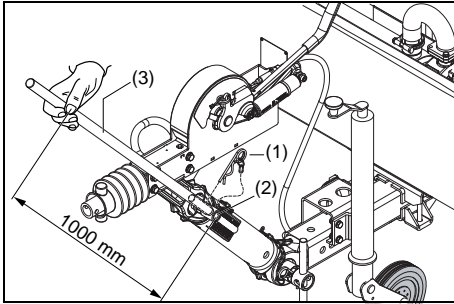

Before towing the compressor, make sure that the joints of the towbar are secured with maximum strength without damaging the towbar. Be sure that there is no clearance between the teeth of the joints.

- Remove spring pin (1).
- Release locking nut (2).
- Adjust required height of the towbar.
- Tighten locking nut (2) by hand.
- Secondly tighten locking nut (2) using an extension tube (3).
- Tighten the locking nut of the upper joint with a handforce of 250 N.
- Tighten the locking nut of the lower joint with a handforce of 400 N.
- Secure locking nut (2) with spring pin (1).
- Height adjustment should be undertaken on levelled ground and in coupled condition.
- When readjusting, make sure that the front point of the towbar is horizontal with the coupling point.
- Before starting a trip, ensure that the adjustment shaft is secure, so that stability and safety is guaranteed while driving. If necessary, tighten the locking nut (2). See alongside.

BALL COUPLING (OPTION)

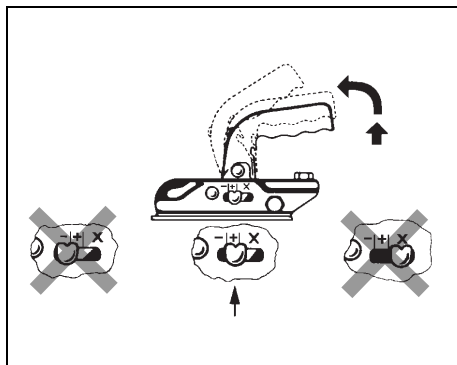

The handle of the ball coupling and the handbrake lever may never be used as a manoeuvring aid; internal components may get damaged!

The coupling (ball coupling) on the tow bar is type approved. The maximum load at the coupling may not be exceeded.

When coupling lower the support leg to the ground. Reverse the car up to the compressor or, in the case of a small compressor, manoeuvre the compressor up to the car's trailer coupling.

Coupling:

Open coupling jaw by pulling the lever vigorously upwards in the direction of the arrow. Lower the opened coupling onto the ball of the vehicle coupling and the lever will automatically be lowered. Closing and locking are carried out automatically. Check the "+" (see figure) position!

Connect the breakaway cable and electrical plug (option) to the towing vehicle. Raise the support leg up fully and secure by firmly clamping it. Release parking brake before setting off.

Visual check: the ball should no longer be visible in coupled condition.

Uncoupling:

Lower the support leg. Disconnect breakaway cable and electrical plug. Pull the lever vigorously upwards in the direction of the arrow and hold. Lift the compressor off the ball of the towing vehicle.

Secure the compressor by means of a wheel chock.

LIFTING INSTRUCTIONS

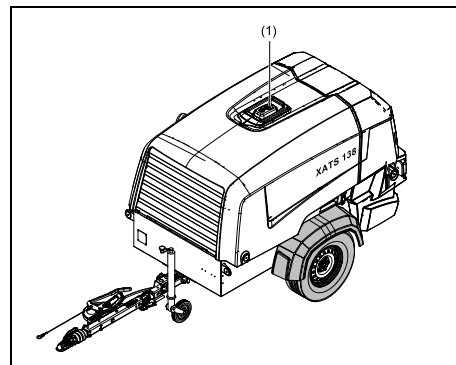

When lifting the compressor, the hoist has to be placed in such a way that the compressor, which must be placed level, is lifted vertically. Keep lifting acceleration and retardation within safe limits.

The lifting eye should preferably be used. The lifting eye is accessible when lifting the rubber flap (1).



Lifting acceleration and retardation must be kept within safe limits (maximum 2kg).

Helicopter lifting is not allowed.

Lifting is not allowed when the unit is running.



Preferably use a lifting rope to avoid damage to the lifting beam structure and canopy.

Use a rope of ample capacity, that is tested and approved according to local safety regulations.

SHIPPING THE COMPRESSOR

Specified shipping vehicle

Use only these shipping vehicles to transport the unit to the required location:

1. Curtain Trailers
2. Open Trailers
3. Winch Trucks

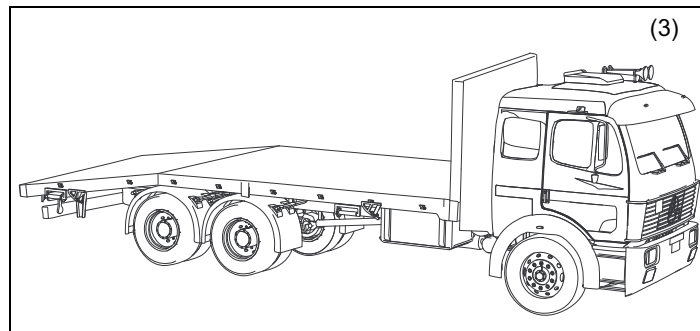
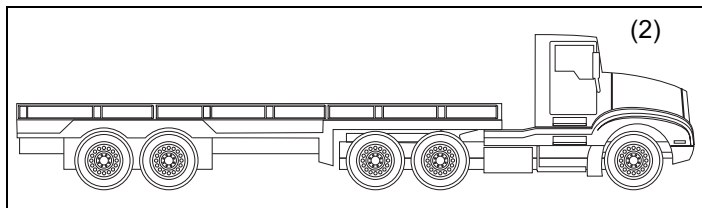
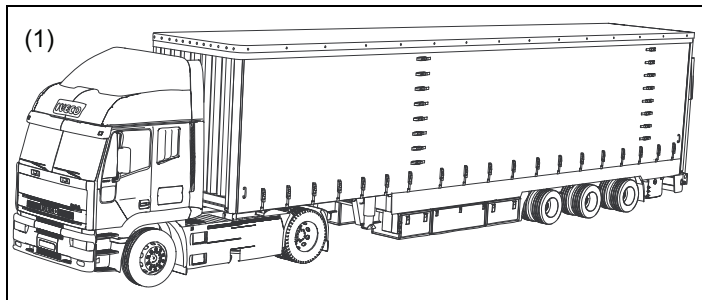

FIXATION TOOLS

Use only CE-approved lashing belts (ratchet straps).

The lashing belts (ratchet straps) must be of type LC 2000 daN and Stf 350 daN.

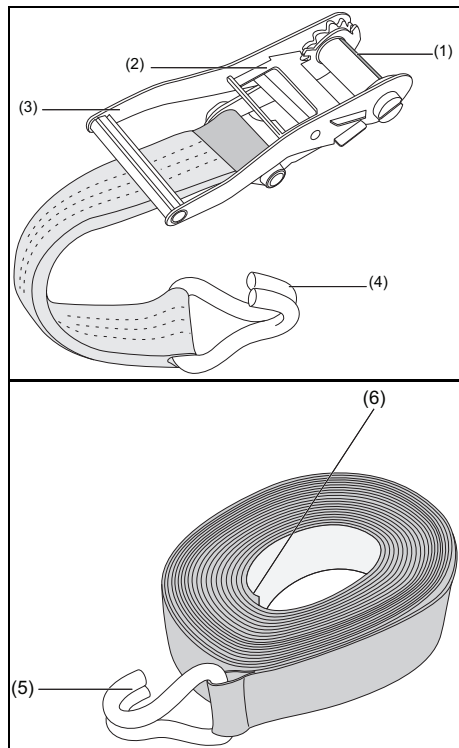

The lashing belt set has two separate belts, the fixed belt and the adjusting belt.

Reference	Description
1	Slot for adjusting belt
2	Ratchet locking tool (Pawl)
3	Ratchet handle
4	Hook of fixed belt
5	Hook of adjusting belt
6	Open end of adjusting belt

Fixing The Lashing Belts

1. Fix the hook of the fixed belt (4) to an eye on the shipping vehicle. Open the ratchet handle (3) on the fixed belt. Raise and lower the ratchet handle (3) till the slot (1) is visible and accessible (as shown in the figure).
2. Fix the hook of the adjusting belt (5) to an eye on the unit. Pass the open end of the adjusting belt (6) through the slot (1) from the bottom to the top.
3. Pull out the open end (6) such that a loop is formed. The open end (6) must be pulled till there is no slack in the adjusting belt.
4. Raise and lower the ratchet handle (3) till the force required to add tension to the belt becomes too great.
5. Push the ratchet handle (3) down to lock the belts in place.

Removing the Lashing belts

1. Open the ratchet handle (3).
2. Pull the ratchet locking tool (2) towards the grip of the ratchet handle (3) to free the tension on the adjusting belt.
3. Pull out the open end of the adjusting belt (6) from the slot (1).
4. Unhook the fixed and adjusting belts from the eyes where they had been fitted.
5. Keep the lashing belts in a safe area.

SECURING THE UNIT TO THE SHIPPING VEHICLE

1. Place the unit in centre position into the shipping vehicle so that the canopy is parallel to the edges of the shipping vehicle.
2. For tie points 1 to 4, hook the four adjusting belts to the eyes of the unit and four fixed belts to the eyes on the shipping vehicle.
3. Place the wooden block below the tow bar to make sure that the floor is not damaged. It is recommended to keep minimum height of 15 cm.
4. Fasten the adjusting belts to the fixed belts, refer to **Fixing The Lashing Belts**. Make sure that an angle of 45° is maintained between the above fitted lashing belts and the horizontal sides of the shipping unit.
5. For tie point 5, fit the hooks of the adjusting belt and the fixed belt to eyes opposite to one another on the shipping vehicle.
6. Fasten the adjusting belt to the fixed belt so that the towing bar is tied down. For the fastening procedure, refer to **Fixing The Lashing Belts**.

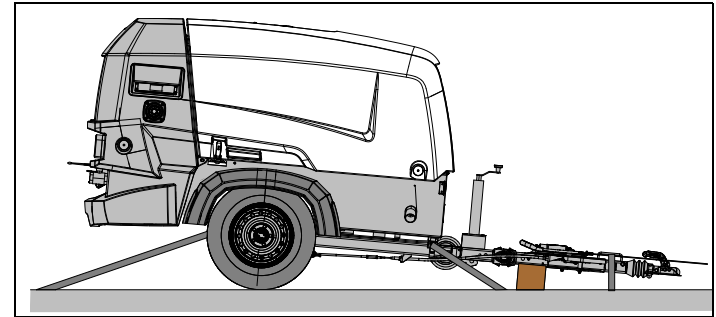
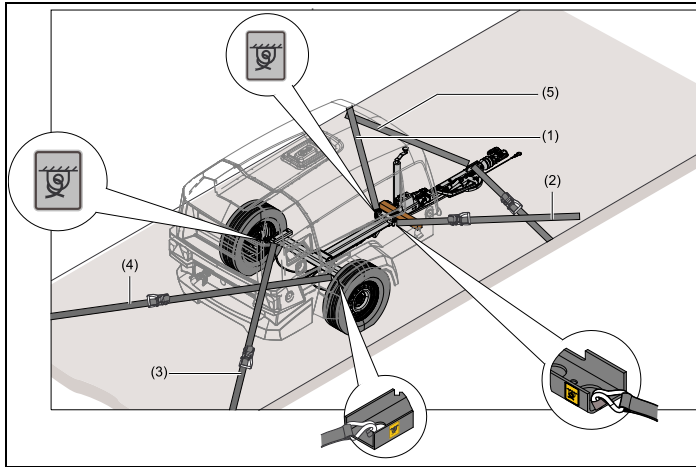
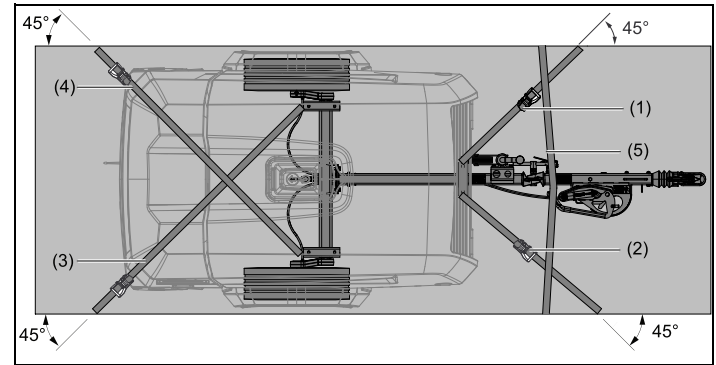

OPERATING THE COMPRESSOR

PREVENT LOW LOADS

Low loads may lead to:

- High oil consumption: prolonged no-load/low load operation of the engine may cause it to blue/grey smoke at low rpm with an associated increase in oil consumption.
- Low combustion temperature: this will result in insufficiently burned fuel, which will cause diluting of the lube oil. Also, unburned fuel and lube oil can enter the exhaust manifold and eventually leak out through joints in the exhaust manifold.
- Risk for fire.

Reduce low load periods to a minimum.

It is recommended that a unit is always used with a load >30% of nominal. Actions should be taken if due to circumstances this minimum load capacity cannot be obtained.



For more info, please contact your Atlas Copco Service Center.

Please note that when a failure occurs and is deemed due to low load operation, repair is not covered by warranty!

BEFORE STARTING

Preparing the battery for operation



Follow the relevant safety instructions during battery use according to section Specific safety precautions before working on or using the battery. Incorrect use of the battery can lead to serious injury and damage to surrounding equipment.



It is suggested to use the prescribed battery for the engine of the unit. While changing the battery, ensure that a battery of same capacity is selected.

- 1 Check the level of electrolyte in the battery. Ensure that the electrode plates are submerged in the electrolyte and that the level of the fluid is within the markings on the battery.
- 2 Ensure that the battery is firmly secured to the battery cradle. Do not over-tighten the cradle clamps as this can damage the battery.
- 3 Clean the battery and all related equipment before use.
- 4 Fit the clamp for the positive terminal before fitting the clamp for the negative terminal.
- 5 Apply petroleum jelly on the terminal or fitted cable clamps.

Overall checks

1. Before initial start-up, prepare battery for operation if not already done. Also see section **Recharging a battery**.
2. With the compressor standing level, check the level of the engine oil. Add oil, if necessary, up to the upper mark on the dipstick. See section **Engine oil level check**.
3. Check the level of the compressor oil. Add oil if necessary. See section **Compressor oil level check**.
4. Check the coolant level at the level gauge on the radiator. If necessary top up with coolant. See section **Topping up of coolant**.
5. Check that the fuel tank contains sufficient diesel fuel. Top up, if necessary. For priming the engine, the fuel must be electrically pumped up by holding the start switch in the "preheat" position, for maximum 20 seconds. If necessary, return to "0" position and repeat. See further starting instructions.
6. Drain leaking fluid from the frame.
7. Check the air filter vacuum indicators (if present). If the yellow piston reaches the red marked service range, have the filter element replaced. After replacing, reset the indicator by pushing the reset button.
8. Press vacuator valves of the air filter to remove dust.
9. Open air outlet valve to allow air flow to the atmosphere.

STARTING/STOPPING



Always use low sulphur diesel and low SAP engine oils. Sulphur poisons the catalytic coating of the Diesel Oxidation Catalyst (DOC) reducing its usefulness.

Avoid running at low loads (unload), as it will generate insufficient heat for a proper functioning of the DOC.

Avoid short term starting and stopping.

Unsuccessful start attempts generate a lot of soot and can cause heavy soot load in the filter.

1. Before initial start-up, prepare battery for operation if not already done. See section **Battery**.
2. With the compressor standing level, check the level of the engine oil. Add oil, if necessary, up to the upper mark on the dipstick. Also check the engine coolant level. Consult the Engine Operation Manual for the type of coolant and type and viscosity grade of the engine oil.
3. Check the level of the compressor oil. See section **Compressor oil level check**. The oil level should be visible in the tube. Add oil if necessary. See section **Oil specification** for the oil to be used.



Before removing the oil filler plug (FP), ensure that the pressure is released by opening an air outlet valve.

4. Check that the fuel tank contains sufficient fuel. Top up, if necessary. Consult the Engine Operation Manual for the type of fuel.

5. Drain any water and sediment from the fuel filters until clean fuel flows from the drain cock.
6. Empty the dust trap of each air filter (AF). See section **Cleaning the dust trap**.
7. Check coolant level in engine coolant top tank. Top up, if necessary. Consult the Engine Operation Manual for coolant specifications.
8. Attach the air line(s) to the closed air outlet valve(s). Connect the safety chain. Use hoses and equipment that is designed to withstand the maximum pressure of the unit (see **Technical specifications**).



No external force may be applied to the air outlet valve(s), e.g. by pulling hoses or by connecting equipment directly to the valve(s).

Safety precautions



Do not disconnect power supply to control box in any way when the control box is switched on. This will cause memory loss.



When the compressor is put in operation for the first time and after running out of fuel or changing the fuel filter, it may take some seconds before the machine will start.

EMERGENCY STOP

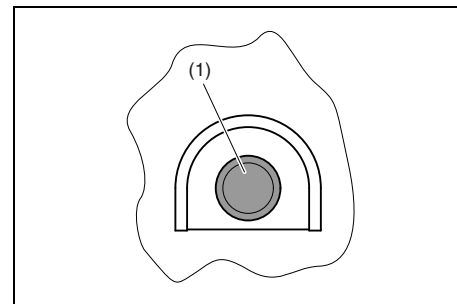

The emergency stop button is only to be used in emergency situations; not for stopping procedures.

When an emergency stop button (1) is pressed, power to all outputs is terminated, by the emergency stop itself (hardware) as well as by the software.

When the emergency stop button (1) is pressed the operator can unlock the emergency stop by turning it counterclockwise.

BASIC OPERATION OF THE MACHINE



The compressor can be controlled in 4 different modes:





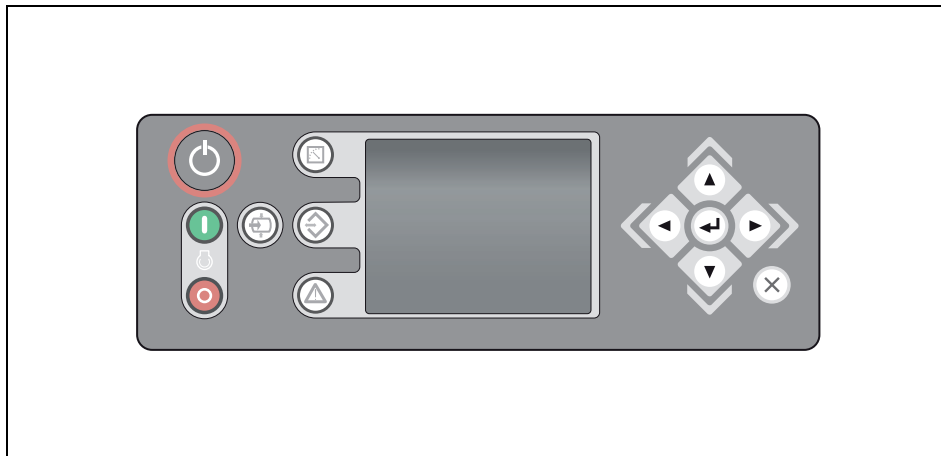

- Local Operation Mode: locally at the Operating Panel,
- Remote Operation Mode: via remote switch inputs located at the bottom of the Control panel,
- Automatic Operation Mode: via pressure sensor data from the customer's installation,
- PC Operation Mode: with software running on a PC.

In this section is described how to operate the machine in Local Operation Mode at the Operation Panel.

CONTROL PANEL









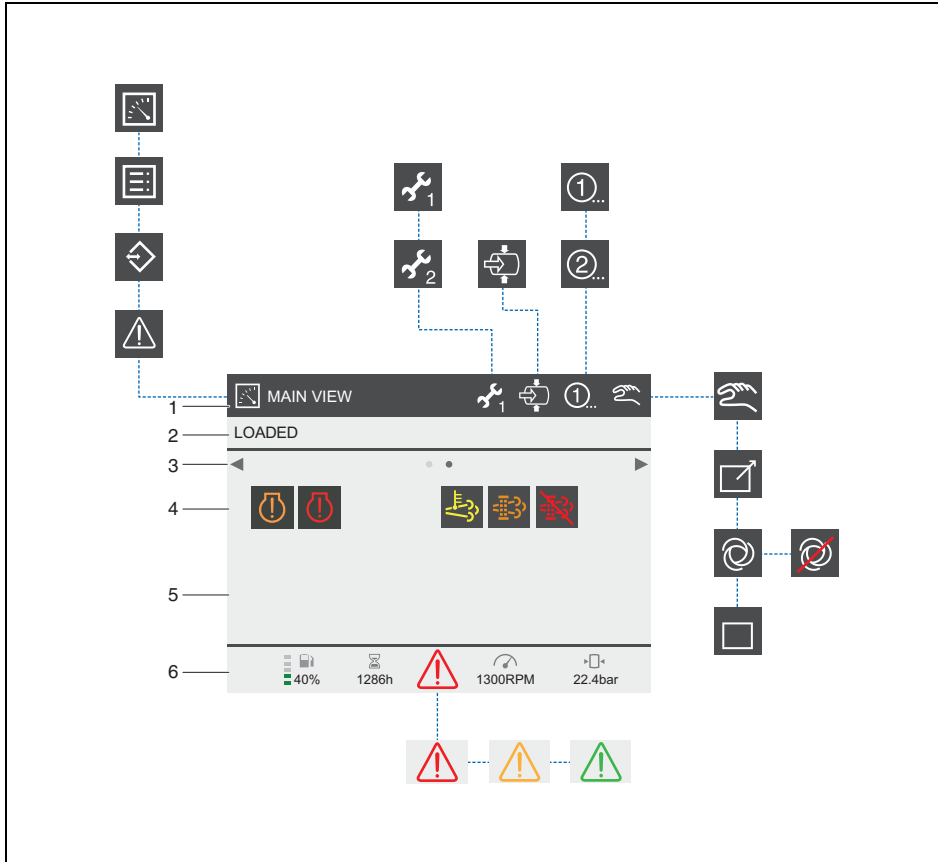





Reference	Name
	Power off / on switch To switch the control panel on and off.
	Start button Pressing this button will start the compressor.
	Stop button Pressing this button will stop the compressor in a controlled way.







Reference	Name
	<p>Load button. Pressing this button will:</p> <ul style="list-style-type: none"> • initiate the Auto Load function, or commands the compressor to load (depending on actual status). • command the compressor to switch to Not Loaded (when in Load).
	<p>Measurements View button By pressing this button you can toggle between Measurements View and Main View.</p>
	<p>Settings View button By pressing this button you can toggle between Settings View and Main View.</p>
	<p>Alarms View button By pressing this button you can toggle between Alarms View and Main View.</p>
	<p>Navigation buttons These buttons are used to navigate through the display menu's.</p>
	<p>Enter button Confirms/stores the selection/change.</p>
	<p>Back button Moves back one level or ignores the change.</p>





OVERVIEW ICONS



Reference	Name
1	View, Overhaul, Auto load, Preset and Active operation mode indication
2	Active compressor status
3	Navigation, toggle between main view and engine view
4	Engine information
5	Vessel pressure indication or information text
6	Alarm indication and compressor information
	 Main View Indication
	 Measuring View Indication
	 Settings View Indication
	 Alarm View Indication

Reference	Name
	Overhaul Minor Overhaul required.
	Overhaul Major Overhaul required.
	Auto Load This icon will be shown if the Auto Load functionality is enabled, or by means of a parameter setting, or by means of pressing the load button before the machine is ready to be loaded.
 	Preset Depending of which Pressure setting is active, the controller will show its dedicated icon.
	Alarm Active & not-acknowledged Shutdown Alarm.
	Alarm Active & not-acknowledged Non-Shutdown Alarm.
	Alarm Active & acknowledged Alarm.

Reference	Name
	Fuel tank Running at internal fuel tank.
	Operation Mode Local
	Operation Mode Remote
	Operation Mode Automatic
	Operation Mode Automatic Mode is active, but the Auto Start and Auto Stop function are both inactive.
	Operation Mode Block Mode

Reference	Name
	Engine warning lamp - amber LED steady on: low alarm LED flashing slow: medium alarm LED flashing fast: high alarm
	Engine shutdown lamp - red LED steady on: low alarm LED flashing slow: medium alarm LED flashing fast: high alarm
	High exhaust system temperature LED steady on: the diesel particulate filter is being regenerated.
	Regeneration of the diesel particulate filter is needed. LED steady on: the diesel particulate filter needs to be regenerated. Contact Atlas Copco. LED flashing: the diesel particulate filter urgently needs to be regenerated. Contact Atlas Copco.
	Regeneration of the diesel particulate filter is inhibited. LED steady on: the regeneration of the diesel particulate filter is inhibited, even if all criteria to activate a regeneration are met. Contact Atlas Copco.

POSSIBLE VIEWS

Main View

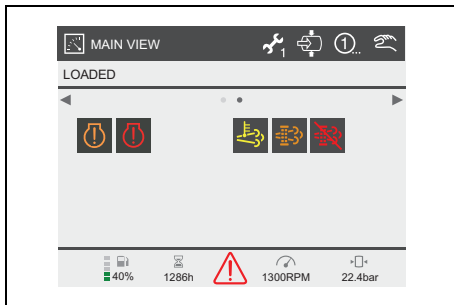
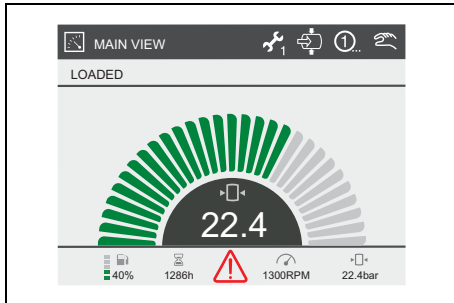

Main view is the default view. In the main view the operator can view the most important information on the actual compressor operation, like:

- Active Sequence
- Vessel pressure
- Engine rpm
- Fuel level
- Running hours
- Alarm indication
- Operation mode
- Pre-set indication
- Auto load indication
- Overhaul indication
- DPF indication

Measurements View

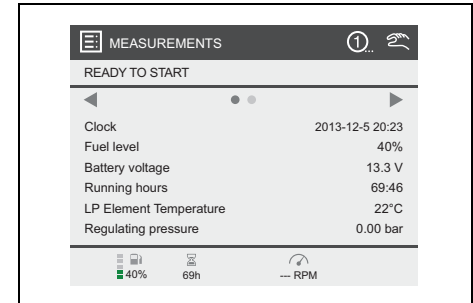

In the measurements view the operator can view up to 100 measured values (depending on the authorisation level).

Use the up and down navigation buttons to scroll through the full list of measurements.

Use the left and right navigation buttons to scroll through the different pages.

The first page contains general data

- Clock
- Fuel level
- Battery voltage
- Running hours
- Vessel pressure
- Regulating pressure
- Emergency stop count
- Loaded hours

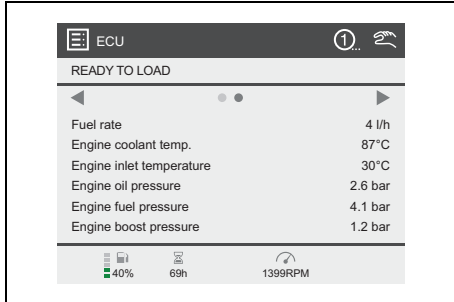

The second page contains engine related data.

- Fuel rate
- Engine coolant temperature
- Engine fuel temperature
- Engine oil temperature
- Engine inlet temperature
- Engine boost pressure
- Engine load
- Engine rpm
- Rpm setpoint
- Ambient temperature

Settings View

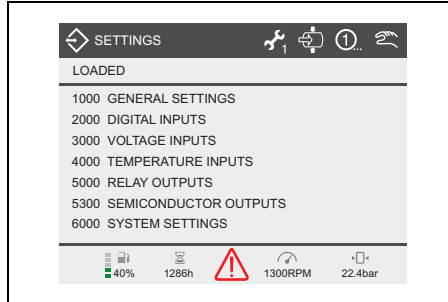

In the settings view the operator can view and change (depending on the authorisation level) various parameters.

Use the up and down navigation buttons to scroll through the full list of settings.

Use the enter button to enter the selected submenu.

Use the back button to leave the entered (sub) menu.

Alarm View

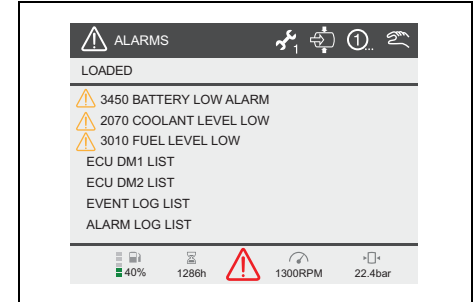

In the alarm view the operator can view the various alarms, actual and history.

Use the up and down navigation buttons to scroll through the full list of alarms.

Use the left and right navigation buttons to scroll through the different Alarm pages:

- General Alarms
- Alarm Log
- DM1 List
- Event Log
- DM2 List

STARTING

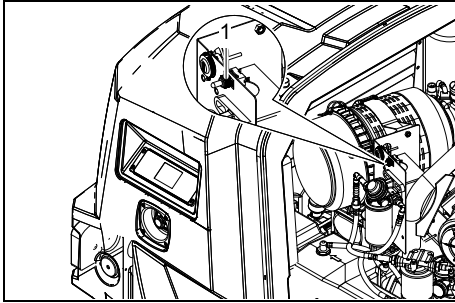

Open the hood and switch on the main switch (1). Close the hood.

Switch the controller on by pressing the Power button.

The instrument panel will now perform a selftest; the following display will be shown and the controller is initialized:

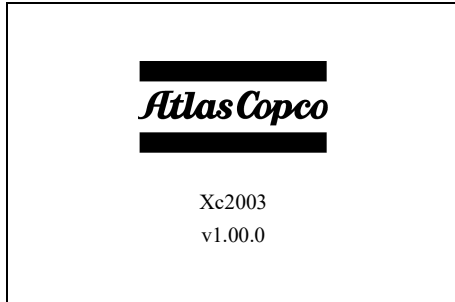

During initializing all buttons/inputs/outputs/alarms are inactive.

This view will be shown for about 2 seconds, after which the display will show the Main View.

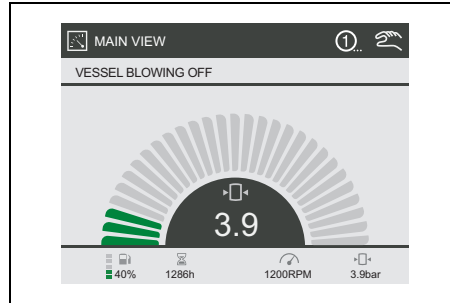

The actual vessel pressure is shown. If the measured vessel pressure is higher than 1.5 bar, the unit will not start. The vessel pressure has to be lowered by opening the blow down valve. After power up, the vessel pressure normally is low enough to proceed with the starting procedure.



If the Power button is switched to switch off while the vessel is blowing down, it will not power down for as long as the vessel pressure is higher than 1.5 bar.



The display will change to

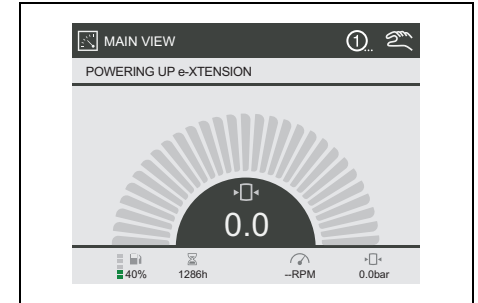

followed by

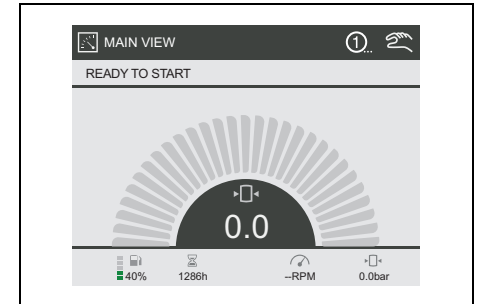

The machine is now ready to be started and is waiting for a start command.

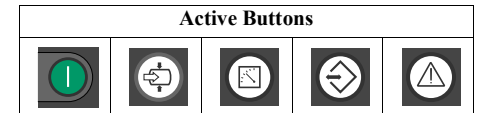

The display will change to

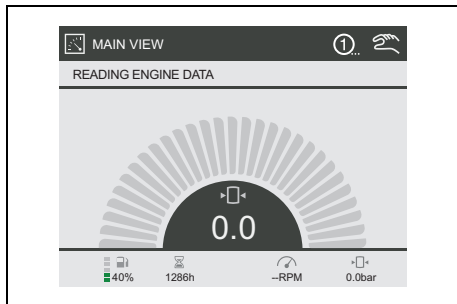

The engine electronics (ECU) will be powered up.

As soon as communication between compressor controller and engine controller is established, the machine will preheat according to the parameters of the engine controller.

The display will change to

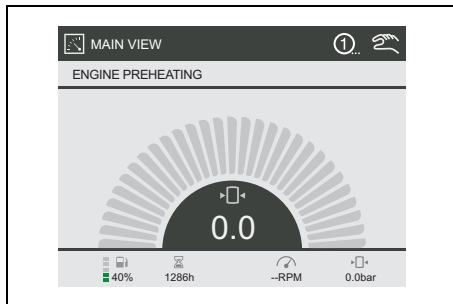

The engine starts cranking, the display shows

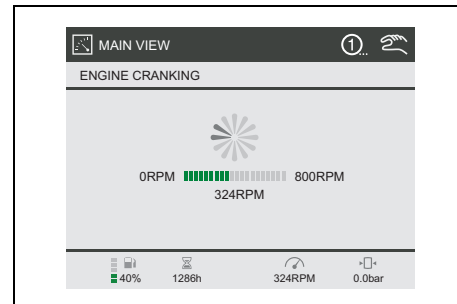

The engine cranks until 800 rpm is reached.

If 800 rpm is not reached within 30 seconds, the starting procedure is cancelled and the engine will rest for some time. (Resting time depends on cranking time).

The display now shows

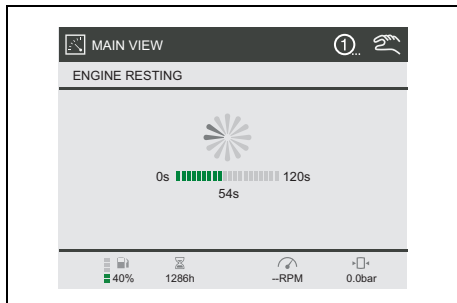

After expiry of the engine resting time a new cranking sequence will start.

Maximum starting attempts is 10.



The engine starts running at idle speed. The display shows

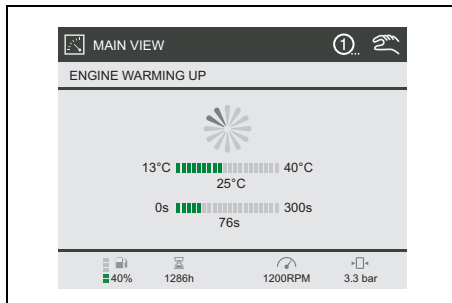

The engine will run at minimum rpm, until the engine's coolant temperature reaches 40°C, with a minimum time of 30 seconds and a maximum time of 300 seconds.

When warming up temperature is reached within 30 seconds the display will show

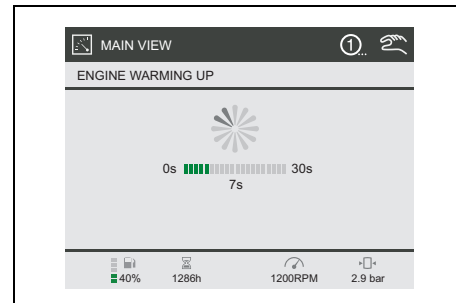

After warming up the machine is ready to be loaded and is waiting for a load command; the display shows

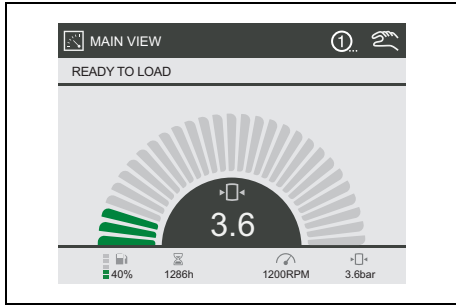

Active Buttons



Press the load button, the display will show

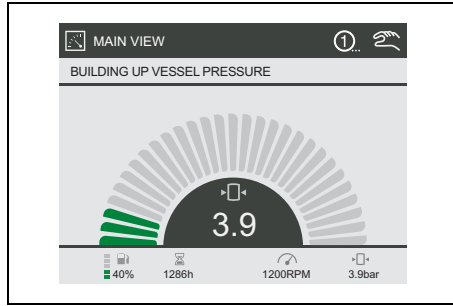

When the load button is pressed and the measured vessel pressure is lower than 4.5 bar, the controller will run a specific program to reach the requested 4.5 bar, in order to be able to load the machine.

Active Buttons



The engine will now run at maximum rpm, the display will show

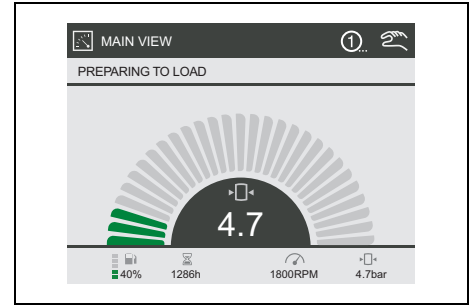

The loading valve will be energized and pressure starts building up.

Active Buttons



During loading the following display is shown (default display)

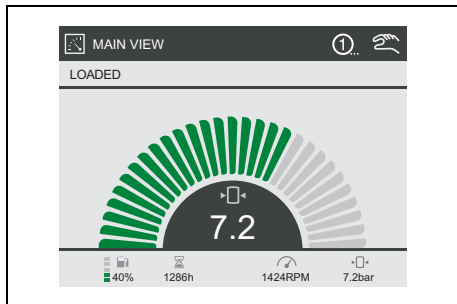

The controller controls the speed of the engine in order to meet the requested working pressure, at the most economical fuel usage.



PRESSURE SETTING

To change the pressure setting there are two possibilities.

1. Choosing between presets

The operator can choose between two preset pressures.

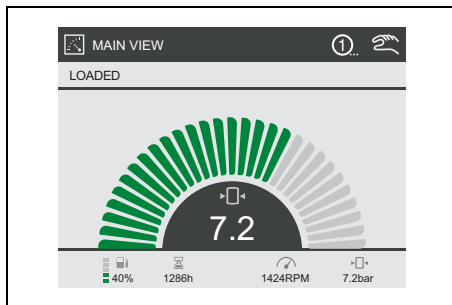

The current active preset is indicated in the top right corner of the display: 1 or 2. To switch to the other preset, go to the Main view and press the enter button for 2 seconds (the pressure set point will light up in green).

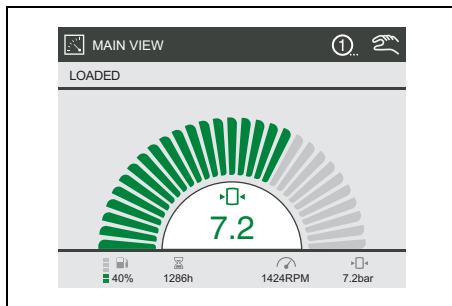

By pressing the left or the right arrow button the operator will be notified to:

“Press enter to go to other pressure setting X Y”

When enter is pressed the setting will become active.

By pressing enter again the controller will go out of edit mode.

The active preset pressure (1 or 2) will be visible in the top right corner of the display.

2. Changing the pressure of a preset

The operator can adjust the active preset as follows.

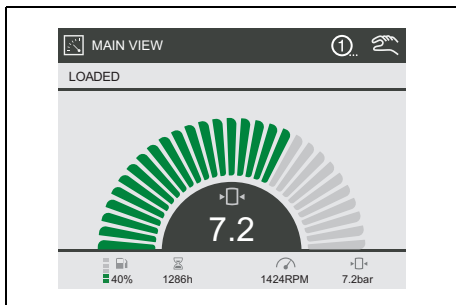

In the Main view when the operator presses the enter button for 2 sec. The pressure setting will light up in green when it is in edit mode.

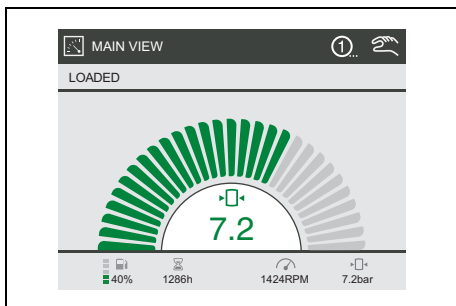

By pressing the up and down buttons the pressure setting can be increased or decreased in 0.1 bar steps.

Pressing the enter button again confirms the pressure setting and will leave the edit mode.

DURING OPERATION



The doors must be closed during operation and may be opened for short periods only.



Be aware not to touch hot parts when the door is open.

Regularly carry out following checks:

1. Check all measurement views for normal readings.
2. Avoid the engine running out of fuel. Nevertheless, if this happens, fill the fuel tank and prime the fuel system to speed up starting.



When the engine is running the air outlet valves (ball valves) must always be in a fully opened or fully closed position.

STOPPING

Press the stop button. Open the air outlet valves to avoid that part of the system will remain pressurized.

After pressing the Stop button the display will show:

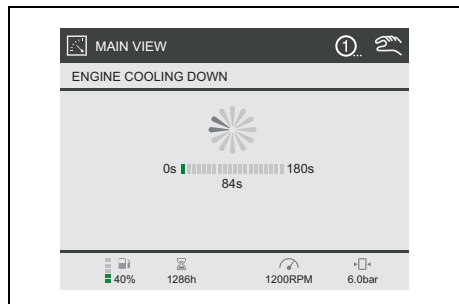

Active Buttons



After cooling down the engine will stop and the display will show

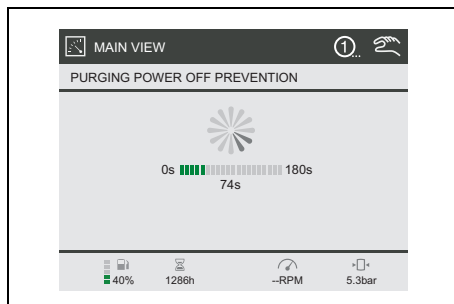

The engine is stopped, and the controller will do a double check to see if the engine is really stopped.

Active Buttons



SHUTDOWN

When the machine is shutdown due to a critical alarm or an emergency stop the display will show

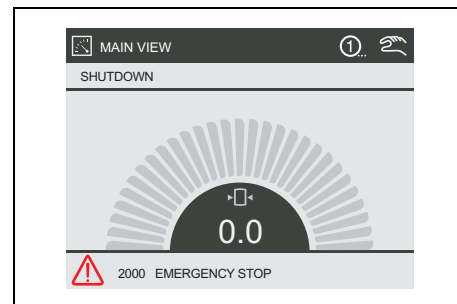

The ENTER button has to be pressed to acknowledge the shown alarm and to be able to proceed.

Active Buttons



POWER OFF

Switch the controller off by pressing the Power button.

When the compressor is not in use, the battery must always be disconnected.

Always first shut off the controller and wait until the display is dark before disconnecting the battery.

SETTINGS

For buttons to be used see section **Control panel**.

Acknowledge an Alarm

If an alarm becomes active, for example a Low Fuel Level Warning:

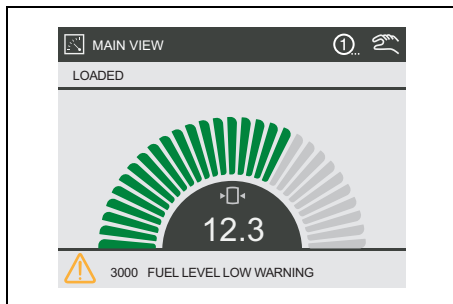

then this alarm can be acknowledged by pressing the Enter button. If the fuel level is still low, the view will change to:

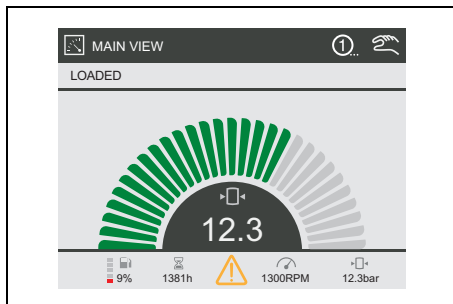

As soon as the fuel level is higher than the warning level, the alarm icon will automatically disappear.

As long as there is an alarm icon in the middle of the bottom part of the view, all active acknowledged / un-acknowledged alarms can be seen by pressing the Alarm View button.

Pressing the Alarm View button again, will bring you back to the Main View.

Set Clock

Press the Settings View button

- scroll to 1000 GENERAL SETTINGS
- press Enter
- scroll to 1290 DATE/TIME
- Enter the DATE/TIME menu
- scroll to the parameter you want to change
- Enter this parameter.

To change the 'RTC Month', scroll to the preferred month and press Enter.

To change any other RTC setting, the red figure is editable.

Scroll up/down and press Enter to change. Use left/right to shift between editable figures.

Now press BACK until you're back in the Main View (or in the menu you require).

Set Language

Press the Settings View button

- scroll to 1000 GENERAL SETTINGS
- press Enter
- scroll to 1300 LANGUAGES
- Enter the LANGUAGES menu
- Enter the SETTINGS parameter
- scroll to the preferred language
- press Enter

Now press BACK until you're back in the Main View (or in the menu you require).

Set Units

Press the Settings View button

- scroll to 1000 GENERAL SETTINGS
- press Enter
- scroll to the unit you would like to change:
1340 TEMPERATURE UNITS
1350 PRESSURE UNITS
1360 FUEL FLOW UNITS
- Enter the preferred menu
- Enter the SETTINGS parameter
- scroll to the preferred setting
- press Enter

Now press BACK until you're back in the Main View (or in the menu you require).

Change Display Settings

Press the Settings View button

- scroll to 1000 GENERAL SETTINGS
- press ENTER
- scroll to 1310 DISPLAY BACKLIGHT
- Enter the DISPLAY BACKLIGHT menu
- scroll to the setting you would like to change
- press Enter

To change a setting, the red figure is editable. Scroll up/down and press Enter to change. Use left/right to shift between editable figure.

Now press BACK until you're back in the Main View (or in the menu you require).

Go To Diagnostics

Press the Settings View button

- scroll to 1000 GENERAL SETTINGS
- press Enter
- scroll to 1150 DIAGNOSTICS
- Enter the DIAGNOSTICS menu
- Enter the ENABLE parameter
- scroll to ON and press Enter

Now the ECU will get PAC (ignition) and one can perform ECU diagnostics (read DM1 List, DM2 List, ECU values, perform engine diagnostics, ...).

Now press BACK until you're back in the Main View (or in the menu you require).

To leave DIAGNOSTICS, press the Stop button.

Set the AutoLoad Function

Press the Settings View button

- scroll to 1000 GENERAL SETTINGS
- press Enter
- scroll to 1160 AUTO LOAD
- Enter the FUNCTION menu
- scroll to AUTO LOAD setting
- press Enter

Now the AutoLoad function is active, and as soon as the unit is Ready To Start, the display will show the Auto Load icon.

Now press BACK until you're back in the Main View (or in the menu you require).

ECO MODE



ECO mode feature is a simplification for the 'Automatic functions'.

The common settings of the automatic functions are grouped in the ECO mode pop-up menu, to make it easier for the end user to modify the settings.

A single pop-up menu avoids to go into four different menu's of the Settings Menu. Not all settings can be done in the pop-up menu. Therefore, the menu structure is still available in the background. By using the ECO mode, the customer can quickly activate the automatic no-load/re-load and automatic stop functions that will help him/her to reduce the fuel consumption. The end user can also change the timers and pressure levels at which the ECO mode functions needs to react on, to optimize the settings for his/her application.

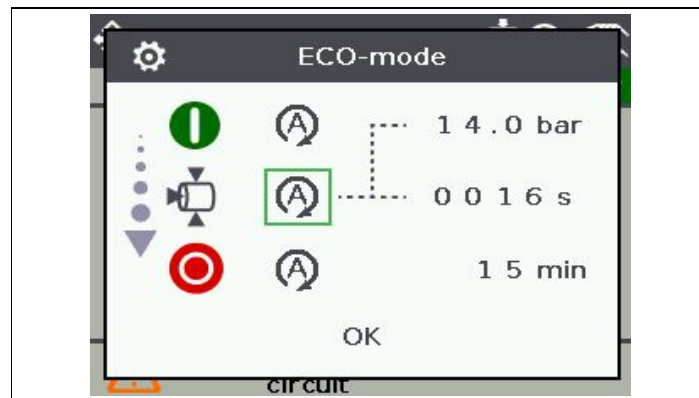
Overview



-  All the features are set to manual operation in the ECO mode pop-up menu by default (in order to avoid unexpected starting and loading of the unit).
-  The compressor unit needs to have the air discharge pressure sensor installed for the ECO mode feature to function.
-  Press 'Load' button to view the ECO mode pop-up menu on the controller screen (only when the machine is not running). If the parameters need to be accessed when the machine is running, then go into Settings menu.

When the ECO mode is active, an icon is displayed in the right upper corner of the controller display as shown below.

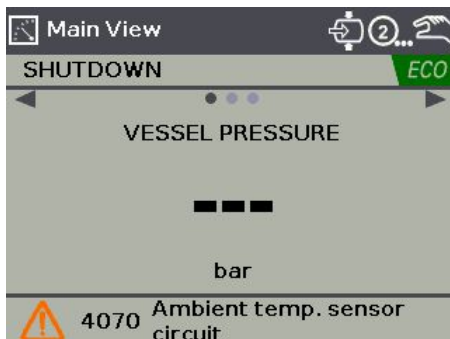

Auto start

The auto start function is used to have the compressor automatically start, when the pressure measured by the air discharge sensor mounted between the MPV and the discharge valve pressure drops under a specified setpoint.

To set auto start function

Press the 'Load' button on controller and the ECO mode pop-up menu appears on the controller display:

- Go to 'Start' icon on the ECO mode pop-up menu and set the parameter to 'Automatic'
- Set the pressure for auto start
 - Once the pressure is set for Auto start; that means if the pressure drops under a specified set pressure, the machine automatically starts.
- Click 'OK' to acknowledge



Auto no-load / auto re-load

The auto no-load function is used for saving fuel when there is no air demand from the application. The compressor switches to no-load operation mode when there is no demand for extended time.

With the auto re-load function, the compressor is loaded again, when there is an air demand.

To set auto no-load & auto re-load

- Select the 'Load' icon on the ECO mode pop-up menu and set the parameter to 'Automatic'
- Set the timer for auto no-load
- Set the pressure for auto re-load
 - Once the pressure is set for auto re-load; that means if the pressure drops under a specified set pressure - the machine is re-loaded automatically.
- Click 'OK' to acknowledge

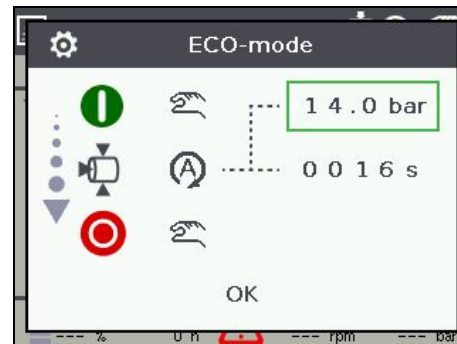

Auto stop

The auto stop function is used to stop the compressor, when there is no air demand over an extended time. This function can be combined with the Auto Start and Auto Load functions. This function can be used for fuel saving.

 **The auto stop must be combined (not only can be combined) with auto start, if you need the machine to start up again after the first stop (otherwise it remains stopped until a manual intervention).**



After setting-up the necessary parameters for each mode, click on 'OK' to acknowledge.

To set auto stop function

- Select the 'Stop' icon on ECO mode pop-up menu and change the parameter to 'Automatic'
- Set the timer for Auto stop and then click 'OK' to acknowledge.



FAULT CODES

The list below is a general list. The messages contained herein do not necessarily apply to your machine.

When one of these parameters exceeds its specified limit the compressor will react depending on the present status of the control box.

There are several parameters that are continuously watched.

Alarmcode	Alarmtext	Failclass
1550	MAJOR OVERHAUL ALARM	WARNING
2000	EMERGENCY STOP	SHUTDOWN
2010	COOLANT LEVEL	SHUTDOWN
2020	CHECK AIR FILTER	WARNING
3000	FUEL LEVEL LOW 1	WARNING
3010	FUEL LEVEL LOW 2	CONTROLLED STOP
3050	VESSEL PRESSURE HIGH WARNING	WARNING
3060	VESSEL PRESSURE HIGH SHUTDOWN	SHUTDOWN
3450	BATTERY LOW ALARM	INDICATION
3460	BATTERY HIGH ALARM	WARNING
4000	LOW PRESSURE ELEMENT TEMP ALARM	INDICATION
4050	AMBIENT TEMP ALARM 1	INDICATION
4060	AMBIENT TEMP ALARM 2	INDICATION
6190	CHARGE MONITORING	WARNING
7010	ENGINE SPEED ALARM 1	SHUTDOWN
7020	ENGINE SPEED ALARM 2	SHUTDOWN
7030	ENGINE COOLANT TEMP	WARNING
7040	ENGINE OIL PRESSURE	WARNING
7050	ENGINE AIR INLET TEMP	WARNING
7070	ENGINE LOAD ALARM	SHUTDOWN
7080	AMBIENT TEMP ALARM	INDICATION
7100	ECU DPF SOOT LOAD HIGH	WARNING
7110	PLEASE FORCE DPF REGENERATION !	INHIBIT LOAD
7120	LOAD PREVENTION - HIGH DPF SOOT LOAD	CONTROLLED STOP
7130	SOOT LOAD TOO HIGH - CALL ATLAS COPCO	WARNING

Maintenance



Unauthorised modifications can result in injuries or machine damage.



Always keep the machine tidy to prevent fire hazard.



Poor maintenance can void any warranty claims.

The operator is only allowed to execute the daily maintenance. All other maintenance/repair is to be done by authorized personnel.

PREVENTIVE MAINTENANCE

Apart from the daily maintenance as described in this section, the unit must be handed in regularly for preventive maintenance.

Preventive maintenance must be carried out by authorized technicians according the maintenance schedule in the workshop manual of the machine.

SERVICE PAKS

A service pak is a collection of parts to be used for a specific maintenance task, e.g. after 500 and after 1000 running hours.

It guarantees that all necessary parts are replaced at the same time keeping down time to a minimum.

The order number of the service paks are listed in the Atlas Copco Part List (ASL).

QR CODE

Scan the QR code to access into the Atlas Copco Spare Part list (ASL).



XATS 138 PE



XAHS 108 PE



XATS 250 PE

Liability

The manufacturer does not accept any liability for any damage arising from the use of non-original parts and for modifications, additions or conversions made without the manufacturer's written approval.

STORAGE

Run the compressor regularly, e.g. twice a week, until warm.

Load and unload the compressor a few times to operate the unloading and regulating components. Close the air outlet valves after stopping.



If the compressor is going to be stored without running regularly, protective measures must be taken.

Contact Atlas Copco for correct measures.

FLEETLINK

The compressor can be equipped with the FleetLink as an option, an intelligent smartbox system for fleet monitoring. Atlas Copco developed both hardware and software to provide you with insights of the compressor performance.

Do the following steps:

1. Go to website <http://fleetlink.atlascopco.com/>.
2. Type the user name and password you received by email.
3. If you are a new user or forget your password, contact Customer Center FleetLink administrator or product management team to set it up.

DAILY MAINTENANCE COMPRESSOR BEFORE STARTING A JOB

Drain condensate and water from spillage-free frame	see Spillage-free frame
Empty air filter vacuator valves	see Air filter engine/compressor
Check engine oil level (if necessary top up)	see Engine oil level check
Check compressor oil level (if necessary top up)	see Compressor oil level check
Check coolant level	see Coolant level check
Check/Fill fuel level after a day's work	
Check air intake vacuum indicators	
Check on abnormal noise	
Check control panel	see Control panel

DAILY MAINTENANCE UNDERCARRIAGE BEFORE A ROADGOING JOB

Check towbar, handbrake lever, spring actuator, reversing lever, linkage and all movable parts for ease of movement	
Check coupling head for damage	
Check height of adjusting facility	see Height adjustment
Check tyre pressure	see Technical specifications
Check safety cable for damage	
Check tyres for uneven wear	



For fluids to be used and their ordering numbers refer to the spare parts manual.

MAINTENANCE SCHEDULE ENGINE AND COMPRESSOR

Maintenance schedule (running hrs)	Notes	Daily	50 hrs after initial start-up	Every 250 hrs	Every 500 hrs	Every 1000 hrs	Yearly	2 Yearly
Drain water from fuel filter		X						
Drain/Clean fuel tank water and sediments	(1)				X			
Drain condensate and water from spillage-free frame or catch basin		X						
Empty air filter vacuator valves		X						
Check engine oil level (if necessary top up)		X						
Check compressor oil level (if necessary top up)		X						
Check coolant level		X						
Check/Fill fuel level	(3)	X						
Check air intake vacuum indicators		X						
Check for leaks in engine, compressor, air, oil, or fuel system			X		X			
Check functioning of regulating valve							X	
Check control panel		X						
Check on abnormal noise		X						
Check electrical system cables for wear			X		X		X	
Check torque on critical bolt connections					X		X	
Check electrolyte level and terminals of battery			X		X		X	
Check engine (minimum and maximum) speed					X		X	
Replace compressor oil filter(s)	(5)					X		X
Inspect/Adjust fan belt			X	X			X	
Replace fan belt					X			X
Hoses and clamps - Inspect/Replace			X		X		X	
Change engine oil	(2)		X		X		X	
Replace engine oil filter	(2)		X		X		X	
Replace fuel (pre)filters	(6)				X		X	

Maintenance schedule (running hrs)	Notes	Daily	50 hrs after initial start-up	Every 250 hrs	Every 500 hrs	Every 1000 hrs	Yearly	2 Yearly
Clean flow restrictor in oil scavenge line					X		X	
Grease hinges							X	
Adjust engine inlet and outlet valves	(2)					X		X
Check/Test glow plugs - grid heater							X	
Test safety valve	(9)						X	
Check rubber flexibles	(11)						X	
Check emergency stop							X	
Clean after cooler (option)	(1)			X			X	
Replace DD/PD/QD filter (option)						X		X
Change compressor oil	(1)(7)					X		X
Replace oil separator element						X		X
Clean oil cooler(s)	(1)				X		X	
Clean radiator	(1)				X		X	
Analyse coolant	(4)(8)						X	
Replace air filter element	(1)					X	X	
Check/Replace safety cartridge						X		X
Inspection by Atlas Copco service technician						X	X	
Check engine & compressor anti-vibration pads					X		X	
Check valve in the fuel return line (for mechanical injection system)				X			X	

MAINTENANCE SCHEDULE UNDERCARRIAGE

Maintenance schedule (km)	Notes	Daily	50 km after initial start-up	Every 2000 km	Yearly	2 Yearly
Check tyre pressure		X				
Check tyres for uneven wear		X				
Check torque of wheel nuts			X		X	
Check towbar handbrake lever spring actuator, reversing lever, linkage and all movable parts for ease of movement.		X				
Grease coupling head, towbar bearings at the housing of the overrun brake					X	
Check brake system (if installed) and adjust if necessary		X				
Oil or grease brake lever and moving parts such as bolts and joints	(1)		X		X	
Grease sliding points on height adjusting parts				X		X
Check safety cable for damage		X				
Check bowden cable on height adjustable connection device for damage		X				
Check brake lining wear		X				
Change wheel hub bearing grease					X	

Notes :



1. More frequently when operating in a dusty environment.
2. Refer to engine operation manual.
3. After a days work.
4. Yearly is only valid when using PARCOOL. Change coolant every 5 years.
5. Use Atlas Copco oil filters, with by-pass valve as specified in the parts list.
6. Gummed or clogged filters means fuel starvation and reduced engine performance.
7. See section **Oil specification**.
8. The following part numbers can be ordered from Atlas Copco to check on inhibitors and freezing points:
 - 2913 0028 00 refractometer
 - 2913 0029 00 pH meter
9. See section **Safety valves**.
10. See section **Before starting**.
11. Replace all rubber flexibles each 6 years.

Other specific engine and alternator requirements, refer to the books.

OIL SPECIFICATION



It is strongly recommended to use Atlas Copco branded lubrication oils for both compressor and engine. If you want to use another brand of oil, consult Atlas Copco.



Never mix synthetic with mineral oil.

ENGINE OIL

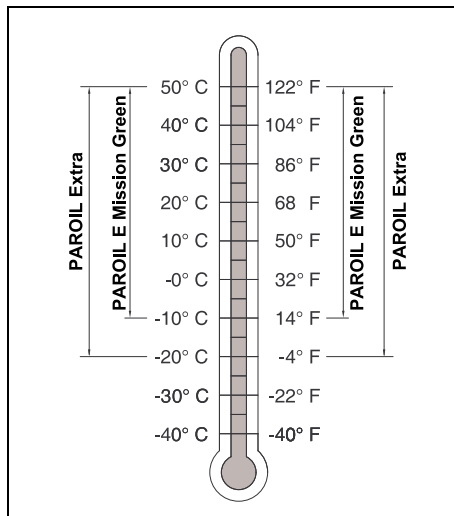

Choose your engine oil based on the ambient temperatures in the actual operating area.

For ordering numbers refer to the spare parts list.

COMPRESSOR OIL

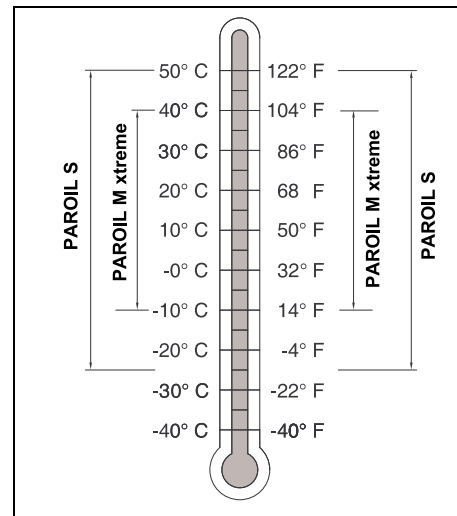

Choose your compressor oil based on the ambient temperatures in the actual operating area.

For ordering numbers refer to the spare parts list.

COMPRESSOR OIL LEVEL CHECK

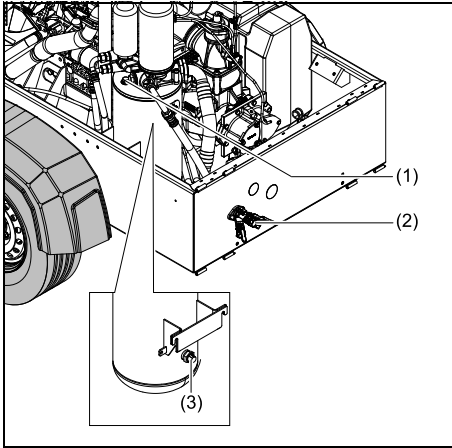

DAILY CHECK

Check the compressor oil level daily, after running the compressor.



The compressor oil level needs to be checked with the compressor in an horizontal position after running the compressor to warm up so that the thermostatic valve is open.

1. Stop the compressor with closed air outlet valve (2) and let it rest for a short period, to allow the system to relief pressure inside the vessel and settle down the oil.
2. Check the oil level via the oil level indicator (3). The pointer must register in the green area. If the oil level is too low, add oil via the oil filler plug (1).



Before removing the oil filler plug, ensure that the pressure is released by opening the air outlet valve and checking the vessel pressure on the controller or the pressure gauge.

3. Top up with oil until the pointer of the oil level gauge is in the upper part of the green area.
4. Reinstall and tighten the filler plug.

CHECK AFTER A LONGER PERIOD WITHOUT RUNNING THE COMPRESSOR

1. Check the oil level via the oil level indicator (3). The pointer must register in the green area.
2. If the oil level is too low, remove the oil filler plug (1) and check if there is still oil in the vessel.
 - No oil in the vessel: Top up the compressor with oil until the pointer of the oil level gauge is in the upper part of the green area and follow the steps as described above in **Daily check**.
 - Oil in the vessel: Start up the unit to warm up and give time for the thermostatic valve to open. Stop the compressor with closed outlet valve and follow the steps described above in **Daily check**.



At temperatures below 0°C, you have to load the compressor to be sure that the compressor thermostat will be open.

ENGINE OIL LEVEL CHECK



Never mix oils of different brands or types.

Use only non-toxic oils where there is a risk of inhaling delivered air.

Let the engine cool down for about 10 minutes. With the compressor standing level, check the level of the engine oil.

Check engine oil level in accordance to the instructions in the Engine Operation Manual and if necessary, top up with oil.

COOLANT



It is strongly recommended to use Atlas Copco branded coolant.



Never mix different coolants and mix the coolant components outside the cooling system.

PARCOOL EG

PARCOOL EG is a ready to use Ethylene Glycol based coolant, premixed in an optimum 50/50 dilution ratio, for antifreeze protection guaranteed to -40°C (-40°F).

For ordering numbers refer to the spare parts list.

Liquid-cooled engines are factory-filled with this type of coolant mixture.

COOLANT LEVEL CHECK

- Check the coolant level at the level gauge on the radiator. If necessary top up with coolant. See section **Topping up of coolant**.
- Low coolant level can lead to engine overheating, and will eventually result in permanent engine damage.

TOPPING UP OF COOLANT



Never remove the cooling system filler cap while coolant is hot.

The system may be under pressure. Remove the cap slowly and only when coolant is at ambient temperature. A sudden release of pressure from a heated cooling system can result in personal injury from the splash of hot coolant.

- Always top-up with PARCOOL EG.
- Topping up the coolant with water only, changes the concentration of additives and is therefore not allowed.

AIR FILTER ENGINE/COMPRESSOR

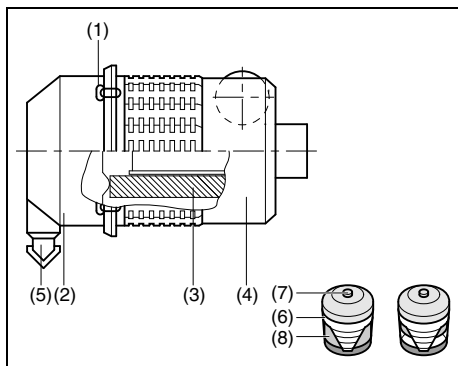

- | | |
|--------------------|---------------------|
| 1. Snap clips | 5. Vacuator valve |
| 2. Dust trap cover | 6. Vacuum indicator |
| 3. Filter element | 7. Reset button |
| 4. Filter housing | 8. Yellow indicator |

CLEANING THE DUST TRAP

To remove dust from the dust trap squeeze the vacuator valve (5) several times.

CLEANING COOLERS

Keep the coolers clean to maintain the cooling efficiency. Open the hood and clean the coolers with a fibre brush and compressed air.



Remove any dirt from the coolers with a fibre brush. Never use a wire brush or metal objects.

Steam cleaning in combination with a cleansing agent may be applied.



To avoid damaging the coolers, angle between jet and coolers should be approx. 90°.



Protect the electrical and controlling equipment, air filters, etc. against penetration of moisture.



Never leave spilled liquids such as fuel, oil, water and cleansing agents in or around the compressor.

BATTERY

RECHARGING A BATTERY

Before and after charging a battery, always check the electrolyte level in each cell; if required, top up with distilled water only. When charging batteries, each cell must be open, i.e. plugs and/or cover removed.



Use a commercial automatic battery charger in accordance with the manufacturer's instructions.

PERIODIC BATTERY SERVICE

- Always keep the batteries clean and dry.
- Refill batteries with distilled water only. Using tap or mineral water, acid, or electrolyte will alter the electrolyte concentration of the battery, affecting its performance.
- Corroded terminals can reduce battery performance or prevent the battery from starting. To prevent the battery terminals from corroding, clean them with a wire brush and apply petroleum jelly on them.
- Do not fast charge a battery as it can cause overheating. Stop charging the battery if its temperature exceeds 50°C (122°F). Such high temperatures reduce battery performance.
- To ensure constant battery performance, check the output of the alternator to prevent over or under charging.
- To check its capacity, track the voltage drop across the battery while starting the starter motor.

If doubtful conditions are noticed or malfunctions arise, keep in mind that the cause may be in the electrical system, e.g. loose terminals, voltage regulator maladjusted, poor performance of compressor, etc.

SPILLAGE-FREE FRAME

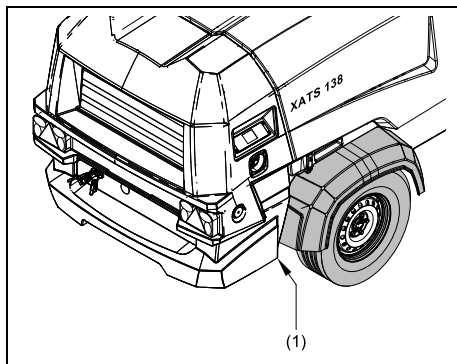

The compressor is fitted with a leak-proof undercarriage in order to protect the environment.

Any leaking fluid is collected in case of malfunctions. This fluid can be removed via a drain (1), normally secured by caps.

Tighten the cap firmly and check for leakages.

Please observe the locally applicable environmental regulations when removing the leaked liquid.

Available options

Towbar:	Adjustable with brakes (A)
	Fixed with brakes (A)
	Fixed with low rider
Without towbar:	Support (without undercarriage)
Towing eyes:	DIN
	GB
	NATO
	BNA
	Ball coupling
	Loose ball coupling
Towbar support:	Support leg
	Jockey wheel
Road lights system:	Full (B)
Refinery equipment:	Spark arrestor
	Inlet shutdown valve
Air quality equipment:	Aftercooler + water separator
	Aftercooler + water separator + bypass
	Aftercooler + water separator + bypass + non return valve
Air outlet valve	1 1/2" ball valve
Cold start:	-20°C (-4°F)

A. These units meet your local safety regulations and are available with overrun and parking brakes.

B. Reflectors and lights for safety on the road.

Problem solving

It is assumed that the engine is in good condition.



If it's not possible to solve the problem with this problem solving table, please consult Atlas Copco.

Problem: Engine loses power, compressor cannot be loaded.

Possible faults	Corrective actions
High soot load in Diesel Particulate Filter causes engine to run in safety mode.	Contact Atlas Copco.

Problem: After working some time, the unit stops through a shutdown switch.

Possible faults	Corrective actions
Engine oil pressure too low.	Refer to the engine instruction manual.
Compressor or engine overheating.	See corrective actions Problem: Compressor overheating.
Fuel tank contains insufficient fuel.	Fill fuel tank.
Low coolant level.	Top up cooling system.

Problem: Air and oil mist expelles from air filters immediately after stopping.

Possible faults	Corrective actions
Plunger of oil stop valve jammed.	Contact Atlas Copco.

Problem: Compressor overheating.

Possible faults	Corrective actions
Insufficient compressor cooling.	Locate compressor away from walls; when banked with other compressors, leave space between them.
Oil cooler clogged externally.	Clean oil cooler. Refer to section Cleaning coolers .
Oil level too low.	Check oil level. Top up with recommended oil if necessary.

Technical specifications

COMPRESSOR / ENGINE SPECIFICATIONS

REFERENCE CONDITIONS

Designation	Unit	XATS 138 PE XATS 250 PE	XATS 138 PE/XATS 250 PE with aftercooler	XAHS 108 PE XAHS 190 PE	XAHS 108 PE/XAHS 190 PE with aftercooler
Absolute inlet pressure	bar(a)	1	1	1	1
	psi	14.5	14.5	14.5	14.5
Relative humidity	%	0	0	0	0
Air inlet temperature	°C	20	20	20	20
	°F	68	68	68	68
Nominal effective working pressure	bar(g)	10.3	10.3	12.0	12.0
	psi	149.4	149.4	174.0	174.0

The inlet conditions are specified at the air inlet grating outside the canopy.

LIMITATIONS

Designation	Unit	XATS 138 PE XATS 250 PE	XATS 138 PE/XATS 250 PE with aftercooler	XAHS 108 PE XAHS 190 PE	XAHS 108 PE/XAHS 190 PE with aftercooler
Minimum effective receiver pressure	bar(g)	5	5	4	4
	psi	72.5	72.5	58.0	58.0
Maximum effective receiver pressure, compressor unloaded	bar(g)	10.3	10.3	13	13
	psi	149.4	149.4	188.5	188.5
Maximum ambient temperature at sea level with aftercooler	°C	45	40	45	40
	°F	113	104	113	104
Minimum starting temperature	°C	-10	-10	-10	-10
	°F	14	14	14	14
Minimum starting temperature, with coldstart equipment	°C	-20	-20	-20	-20
	°F	-4	-4	-4	-4

PERFORMANCE DATA (3) (4)

Designation	Unit	XATS 138 PE XATS 250 PE	XATS 138 PE/XATS 250 PE with aftercooler	XAHS 108 PE XAHS 190 PE	XAHS 108 PE/XAHS 190 PE with aftercooler
Engine shaft speed, normal and maximum					
At pressure setting (bar(g)) 7	rpm	2700	2700	-	-
At pressure setting (bar(g)) 8.6	rpm	2450	2450	-	-
At pressure setting (bar(g)) 10.3	rpm	2200	2200	-	-
At pressure setting (bar(g)) 12	rpm	-	-	2700	2700
Engine shaft speed, compressor unloaded	rpm	1800	1800	1800	1800
Fuel consumption (4)					
At 100% FAD (full load)	kg/h	11.01	11.01	10.97	10.97
	lb/h	24.3	24.3	24.2	24.2
At 75% FAD	kg/h	7.39	7.39	7.8	7.8
	lb/h	16.3	16.3	17.1	17.1
At 50% FAD	kg/h	6.15	6.15	6.36	6.36
	lb/h	13.6	13.6	14.0	14.0
At 25% FAD	kg/h	5.38	5.38	5.95	5.95
	lb/h	11.9	11.9	13.1	13.1
At 0% FAD (unload)	kg/h	4.36	4.36	4.94	4.94
	lb/h	9.6	9.6	10.9	10.9
Specific fuel consumption at 100% FAD (4)	g/m ³	26.4	26.4	34.5	34.5
Maximum typical oil content of compressed air	mg/m ³	5	5	5	5
Engine oil consumption (maximum)	g/h	17	17	17	17
Compressed air temperature at outlet valve without aftercooler or aftercooler bypassed	°C	81	34	79	34
	°F	178	93.2	174.2	93.2
Noise sound pressure level (Lp)	dB(A)	70	70	70	70
(Lp) measured according to		ISO 2151	ISO 2151	ISO 2151	ISO 2151
Noise sound power level (Lw)	dB(A)	98	98	98	98
(Lw) measured according to		2000/14/EC	2000/14/EC	2000/14/EC	2000/14/EC

DESIGN DATA

Compressor

Number of compression stages	XATS 138 PE XATS 250 PE	XATS 138 PE/XATS 250 PE with aftercooler	XAHS 108 PE XAHS 190 PE	XAHS 108 PE/XAHS 190 PE with aftercooler
	1	1	1	1

Engine

Designation	Unit	XATS 138 PE XATS 250 PE	XATS 138 PE/XATS 250 PE with aftercooler	XAHS 108 PE XAHS 190 PE	XAHS 108 PE/XAHS 190 PE with aftercooler
Make		Kubota	Kubota	Kubota	Kubota
Type		V2403-CR-T-E5B	V2403-CR-T-E5B	V2403-CR-T-E5B	V2403-CR-T-E5B
Coolant		ParCool EG	ParCool EG	ParCool EG	ParCool EG
Number of cylinders		4	4	4	4
Bore	mm	87	87	87	87
	in	3.43	3.43	3.43	3.43
Stroke	mm	102.4	102.4	102.4	102.4
	in	4.03	4.03	4.03	4.03
Swept volume	l	2.4	2.4	2.4	2.4
	cu in	146.5	146.5	146.5	146.5
Power output at normal shaft speed (kW)	kW	48.6	48.6	48.6	48.6
	BHP	65.2	65.2	65.2	65.2
Output according to		ISO 9249G	ISO 9249G	ISO 9249G	ISO 9249G
Capacity of oil sump:- Initial fill	l	9.5	9.5	9.5	9.5
	US gal	2.5	2.5	2.5	2.5
Capacity of oil sump : - Refill (maximum) (2)	l	9	9	9	9
	US gal	2.4	2.4	2.4	2.4
Capacity of cooling system	l	11.5	11.5	11.5	11.5
	US gal	3.0	3.0	3.0	3.0

Unit

Designation	Unit	XATS 138 PE XATS 250 PE	XATS 138 PE/XATS 250 PE with aftercooler	XAHS 108 PE XAHS 190 PE	XAHS 108 PE/XAHS 190 PE with aftercooler
Capacity of compressor oil system	l	11	11	11	11
	US gal	2.9	2.9	2.9	2.9
Net capacity of air receiver	l	30	30	30	30
	US gal	7.9	7.9	7.9	7.9
Air volume at inlet grating (approx.) (1)	m ³ /s	2.7	2.7	2.7	2.7
Capacity of standard fuel tanks	l	87	87	87	87
	US gal	23	23	23	23

1 Air required for engine and compressor cooling, combustion and for compression.

2 With filter change.

3 At reference conditions unless otherwise stated.

4 To account for fuel used during regeneration the fuel consumption values have to be increased with 1.5%. This is an average percentage and is dependent on the working conditions of the compressor.

ALTITUDE UNIT PERFORMANCE CURVES

Maximum allowable working pressure as a function of altitude and ambient temperature.

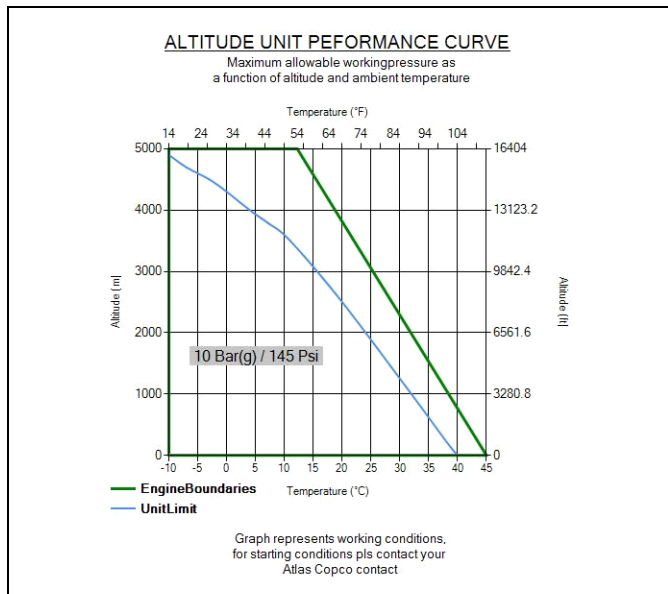

XATS 138 PE/XATS 250 PE

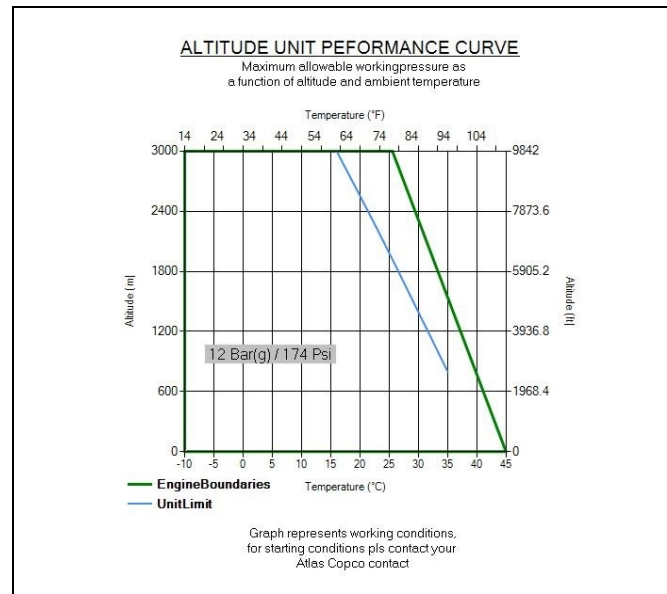

XAHS 108 PE/XAHS 190 PE

Graphic represents working conditions. For starting conditions, please contact your Atlas Copco service centre.

Dimension drawing

DIMENSIONS DRAWING- 9822 0179 00

Dry Mass		Center of Gravity				Wet Mass	
Xz	Yz	Zz	Xz	Yz	Zz	Xz	Yz
Kg (lbs)	mm (inches)	mm (inches)	mm (inches)	Kg (lbs)	mm (inches)	mm (inches)	mm (inches)
1102 (2429.49)	545 (21.46)	1041 (40.98)	312 (12.28)	1164 (2566.18)	530 (20.87)	1036 (40.79)	282 (11.10)

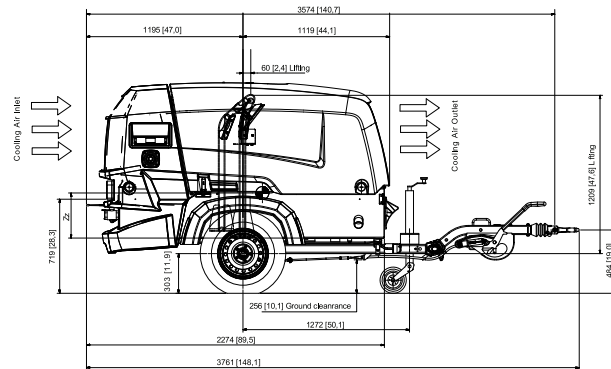
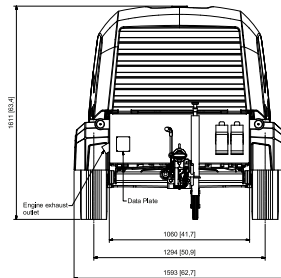
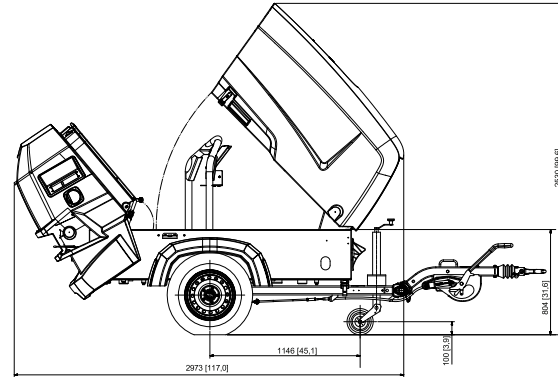
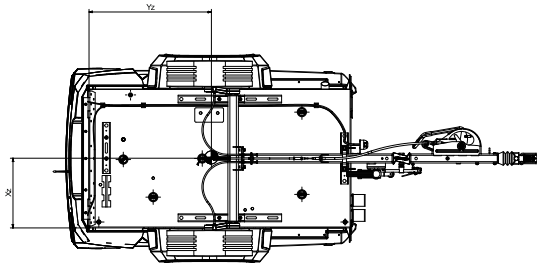

DIMENSIONS DRAWING- 9822 0180 00

Center of Gravity							
Dry Mass	Xz	Yz	Zz	Wet Mass	Xz	Yz	Zz
Kg (lbs)	mm (Inches)	mm (Inches)	mm (Inches)	Kg (lbs)	mm (Inches)	mm (Inches)	mm (Inches)
1102 (2429,49)	545 [21,46]	1041 [40,98]	312 [12,28]	1164 (2566,18)	530 [20,87]	1036 [40,79]	282 [11,10]

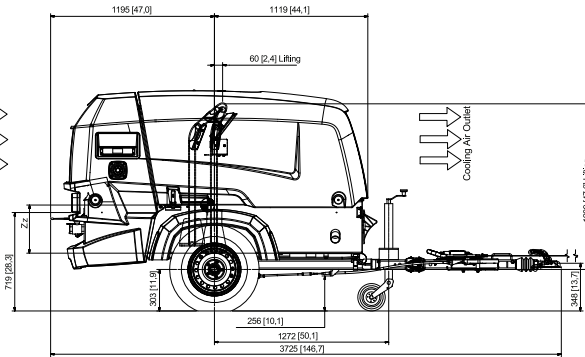
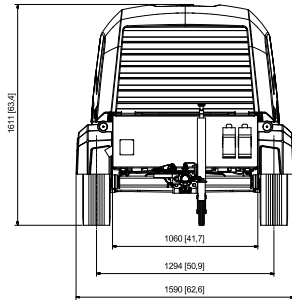
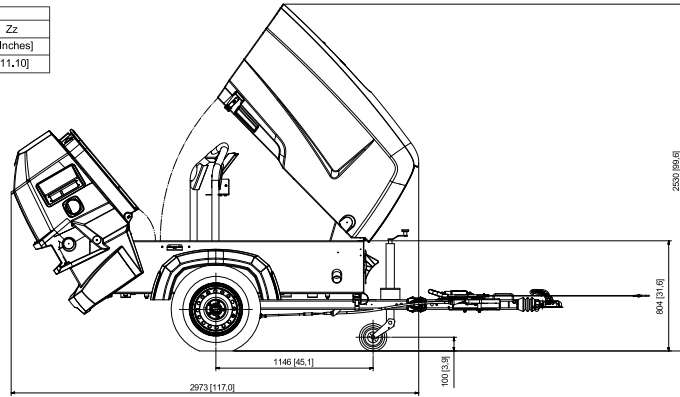
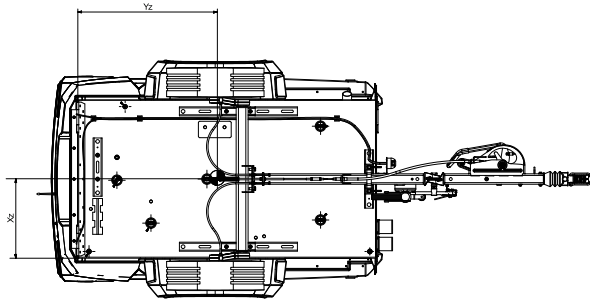

DIMENSIONS DRAWING- 9822 0181 00

Dry Mass	Center of Gravity			Wet Mass	Center of Gravity		
	Xz	Yz	Zz		Xz	Yz	Zz
Kg (lbs)	mm [inches]	mm [inches]	mm [inches]	Kg (lbs)	mm [inches]	mm [inches]	mm [inches]
1117 (2462.56)	545 [21.46]	1066 [41.97]	312 [12.28]	1179 (2599.25)	545 [21.46]	1061 [41.77]	282 [11.10]

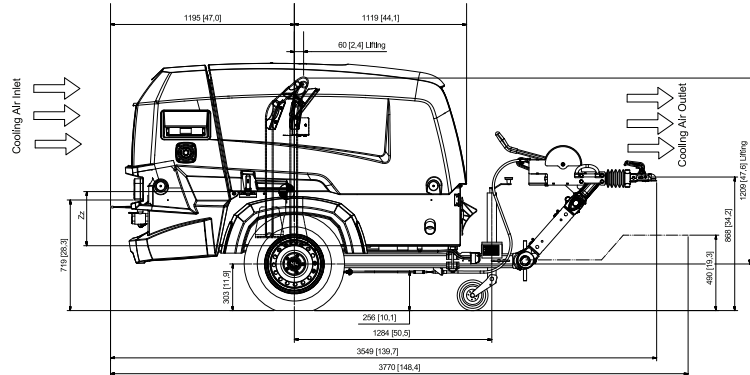
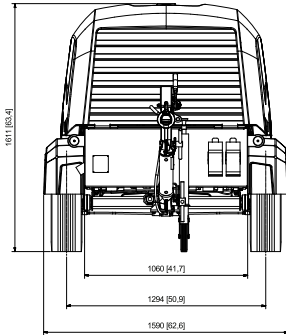
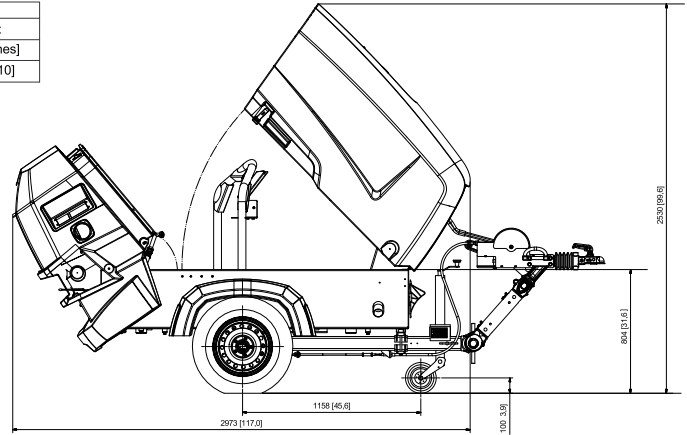
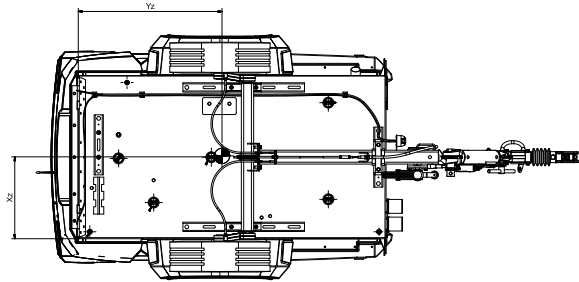

DIMENSIONS DRAWING- 9822 0205 00

Center of Gravity								
Dry mass	Xz	Yz	Zz	Wet Mass	Xz	Yz	Zz	
Kg (lbs)	mm [Inches]	mm [Inches]	mm [Inches]	Kg (lbs)	mm [Inches]	mm [Inches]	mm [Inches]	
1037 (2286.19)	545 [21.46]	999 [39.33]	327 [12.87]	1099 (2422.88)	545 [21.46]	994 [39.13]	297 [11.69]	

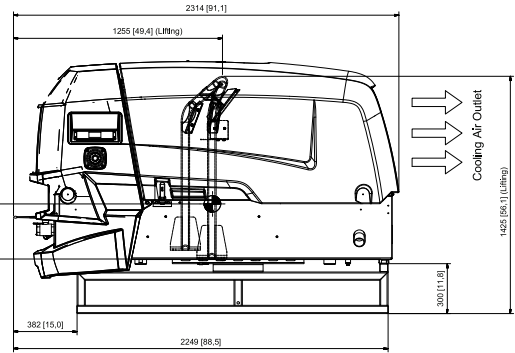
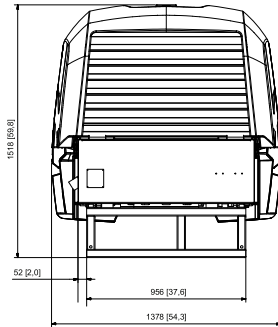
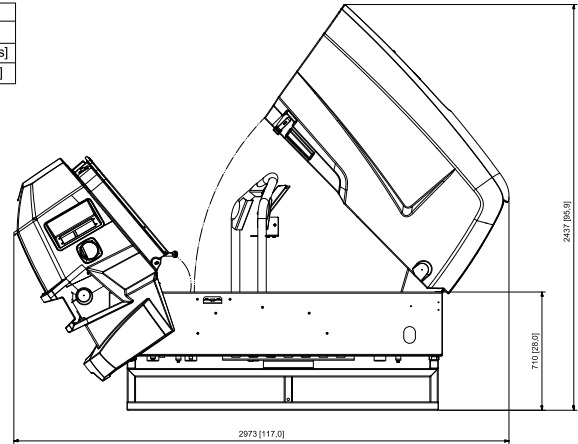
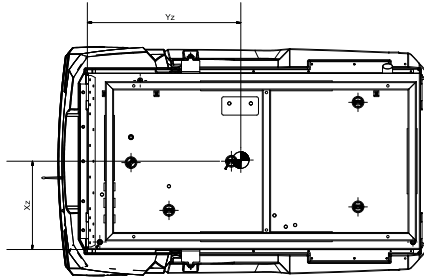

Electrical diagram

CIRCUIT DIAGRAM - 9822 1111 48-01

INDEX	
SHEET	DESCRIPTION
01	INDEX & LEGEND
02	LEGEND
03	MAIN CIRCUIT
04	CONTROLLER
05	CONTROL MODULE
06	DOC/SCR WIRING
07	COLD START

02

Color codes

0 = black	5 = green
1 = brown	6 = blue
2 = red	7 = purple
3 = orange	8 = grey
4 = yellow	9 = white

Wire sections

aaa = 0,35mm ²
aa = 0,5 mm ²
ab = 0,75 mm ²
a = 1 mm ²
b = 1,5 mm ²
c = 2,5 mm ²
d = 4 mm ²
e = 6 mm ²
f = 10 mm ²
h = 16 mm ²
j = 50 mm ²
k = 95 mm ²

LEGEND					
TAGNAME	DESCRIPTION	FUNCTION	LOCATION	PAGE	REF
D1	DIODE	COLD START	MACHINE	07	5
F1	FUSE	MAIN RELAY FUSE 25A	CONTROL BOX	03	5
F11	FUSE	PREHEATER FUSE 50A	CONTROL BOX	03	6
F2	FUSE	ECU FUSE 5A	CONTROL BOX	03	4
F3	FUSE	ECU FUSE 5A	CONTROL BOX	04	4
F4	FUSE	EGR FUSE 5A	CONTROL BOX	06	2
F5	FUSE	GENERAL FUSE 10A	CONTROL BOX	03	5
F6	FUSE	HEATER EPRS 10A	CONTROL BOX	03	6
F7	FUSE	ISV 10A	CONTROL BOX	03	7
F8	FUSE	ALTERNATOR FUSE 10A	CONTROL BOX	03	3
G1	BATTERY	POWER	CANOPY	03	1
G2	ALTERNATOR	CHARGING	MACHINE	03	4
K0	RELAY	START	CANOPY	03	3
K1	RELAY	STARTER RELAY	CUBICLE	05	5
K2	RELAY	MAIN RELAY	CUBICLE	05	9
K3	RELAY	HEATER EPRS RELAY	CUBICLE	04	7
K4	RELAY	HEATER EPRS RELAY	CUBICLE	04	6
K5	RELAY	PREHEATER RELAY	CUBICLE	05	1
LS1	LEVEL SENSOR	FUEL LEVEL	MACHINE	04	1
M1	MOTOR	STARTER	CANOPY	03	2
M2	MOTOR	FUEL FEED PUMP	CANOPY	06	2
PT1	PRESSURE SENSOR	VESSEL PRESSURE	MACHINE	04	5
PT2	PRESSURE SENSOR	REGULATING PRESSURE	MACHINE	04	2
PT3	PRESSURE SENSOR	DIFFERENTIAL PRESSURE	MACHINE	05	2
R1	HEATER	EPRS HEATER	MACHINE	04	6
R2	HEATER	PREHEATER	MACHINE	03	6
S0	SWITCH	BATTERY	CANOPY	03	1
S1	SWITCH	ON/OFF	CANOPY	03	5

CIRCUIT DIAGRAM - 9822 1111 48-02

TAGNAME	DESCRIPTION	FUNCTION	LOCATION	PAGE	REF
S2	SWITCH	EMERGENCY STOP	MACHINE	04	3
TT1	TEMPERATURE SENSOR	ELEMENT TEMPERATURE	MACHINE	04	3
TT2	TEMPERATURE SENSOR	DPF TEMPERATURE T0	MACHINE	05	3
TT3	TEMPERATURE SENSOR	DPF TEMPERATURE T1	MACHINE	05	3
TT4	TEMPERATURE SENSOR	DPF TEMPERATURE T2	MACHINE	05	4
TT5	TEMPERATURE SENSOR	AMBIENT TEMPERATURE	MACHINE	04	7
X1	CONNECTOR	ECU CONNECTOR-X1	CANOPY	05	2
X10	CONNECTOR	INLET SHUTDOWN VALVE	MACHINE	04	8
X11	CONNECTOR	COLD START	MACHINE	07	5
X12	CONNECTOR	COLD START	MACHINE	07	5
X13	CONTROL MODULE	COMAP I-LBA	MACHINE	07	4
X2	CONNECTOR	ECU CONNECTOR- X2	CANOPY	05	7
X3	CONTROL MODULE	XC2003	CUBICLE	04	2
X4	CONNECTOR	ENGINE INTERMEDIATE A	MACHINE	06	1
X5	CONNECTOR	ENGINE INTERMEDIATE B	MACHINE	06	7
X6	CONNECTOR	USB HOST	MACHINE	04	6
X7	CONNECTOR	DIAGNOSTIC	MACHINE	05	8
X8	CONNECTOR	CAN-J1939	MACHINE	05	7
X9	CONNECTOR	AIR FLOW SENSOR	MACHINE	05	7
Y1	EPRS SOLENOID	VALVE	MACHINE	04	5
Y2	LOADING	VALVE	MACHINE	04	7

02

02

CIRCUIT DIAGRAM - 9822 1111 48-03

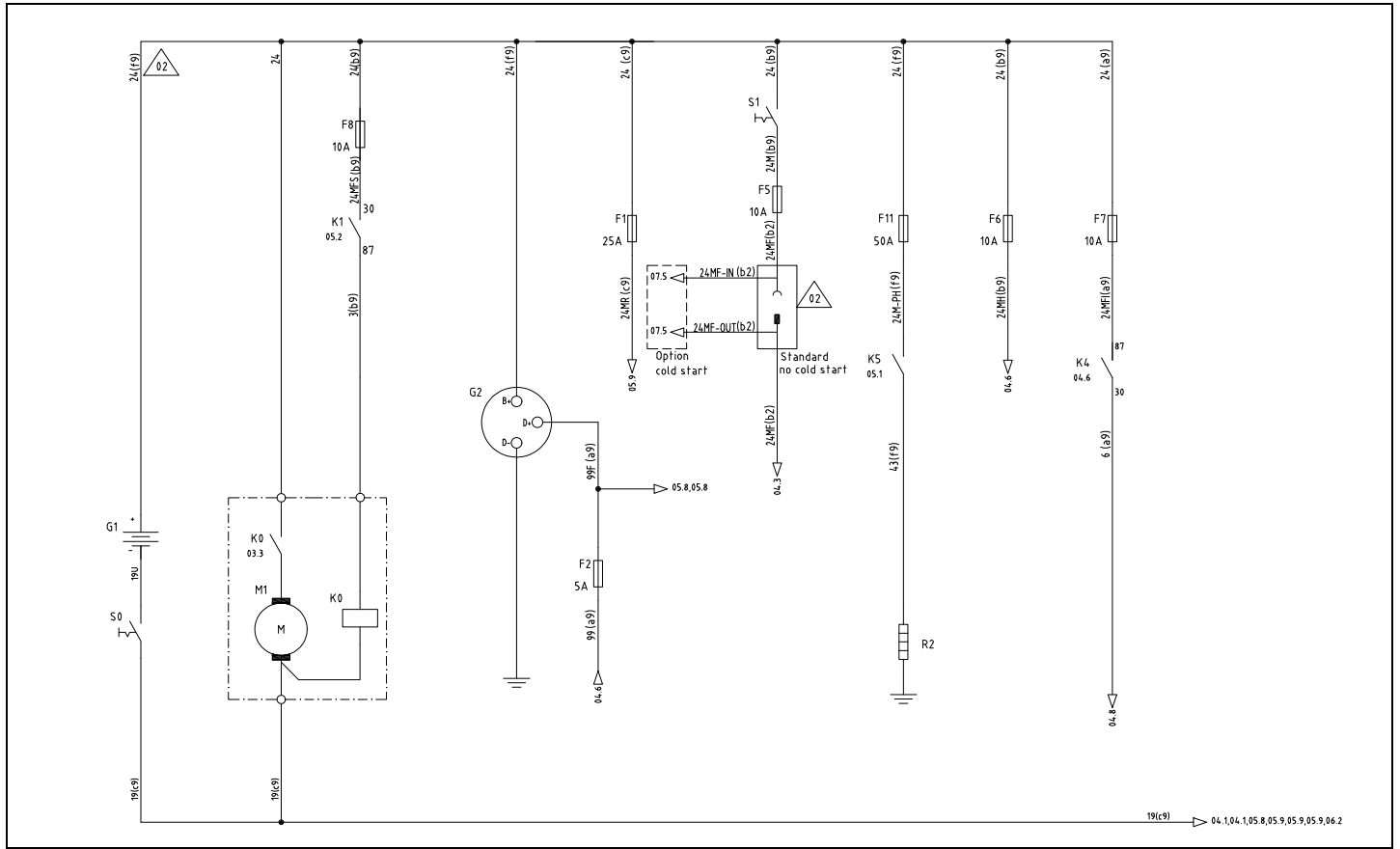

CIRCUIT DIAGRAM - 9822 1111 48-04

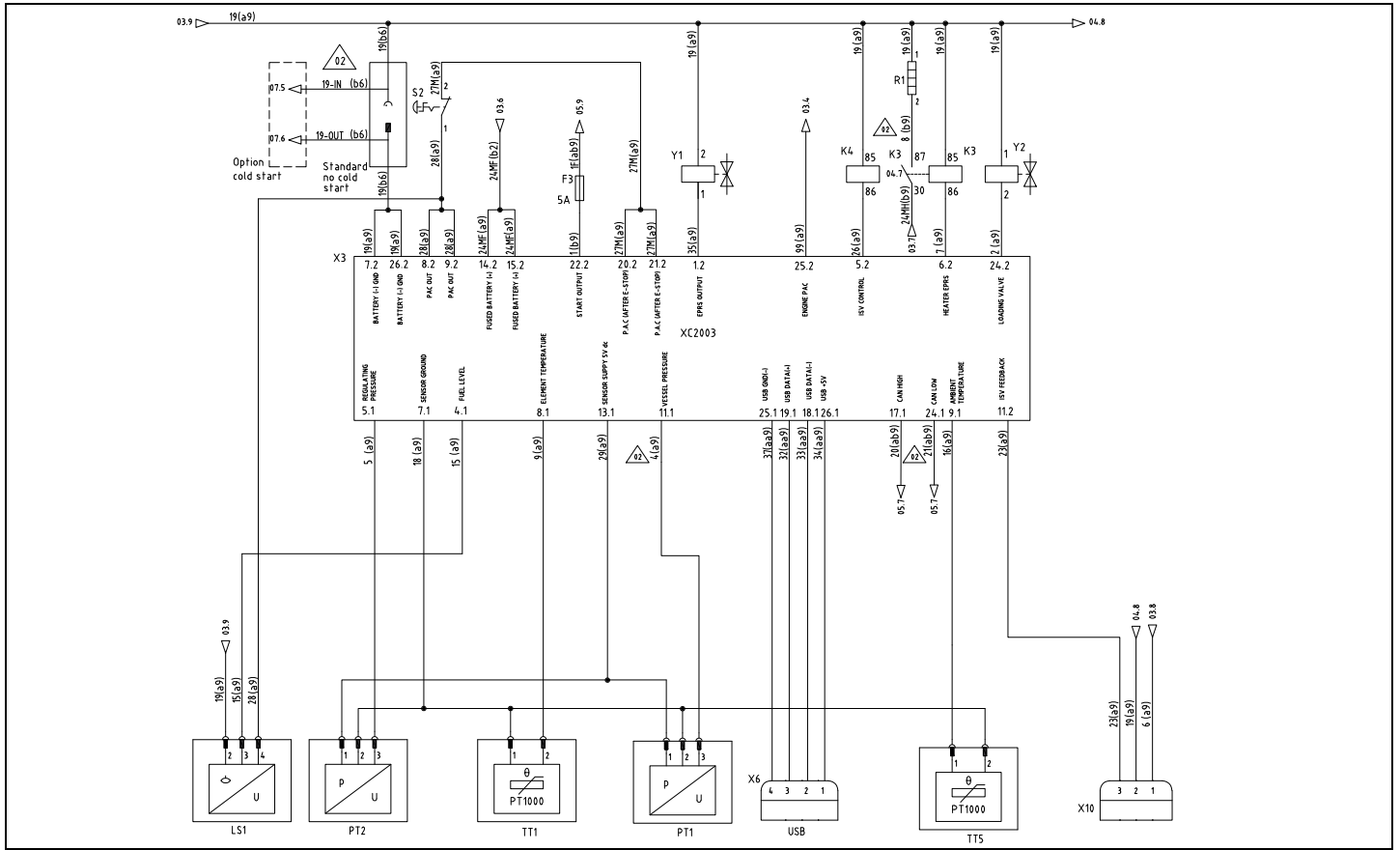

CIRCUIT DIAGRAM - 9822 1111 48-05

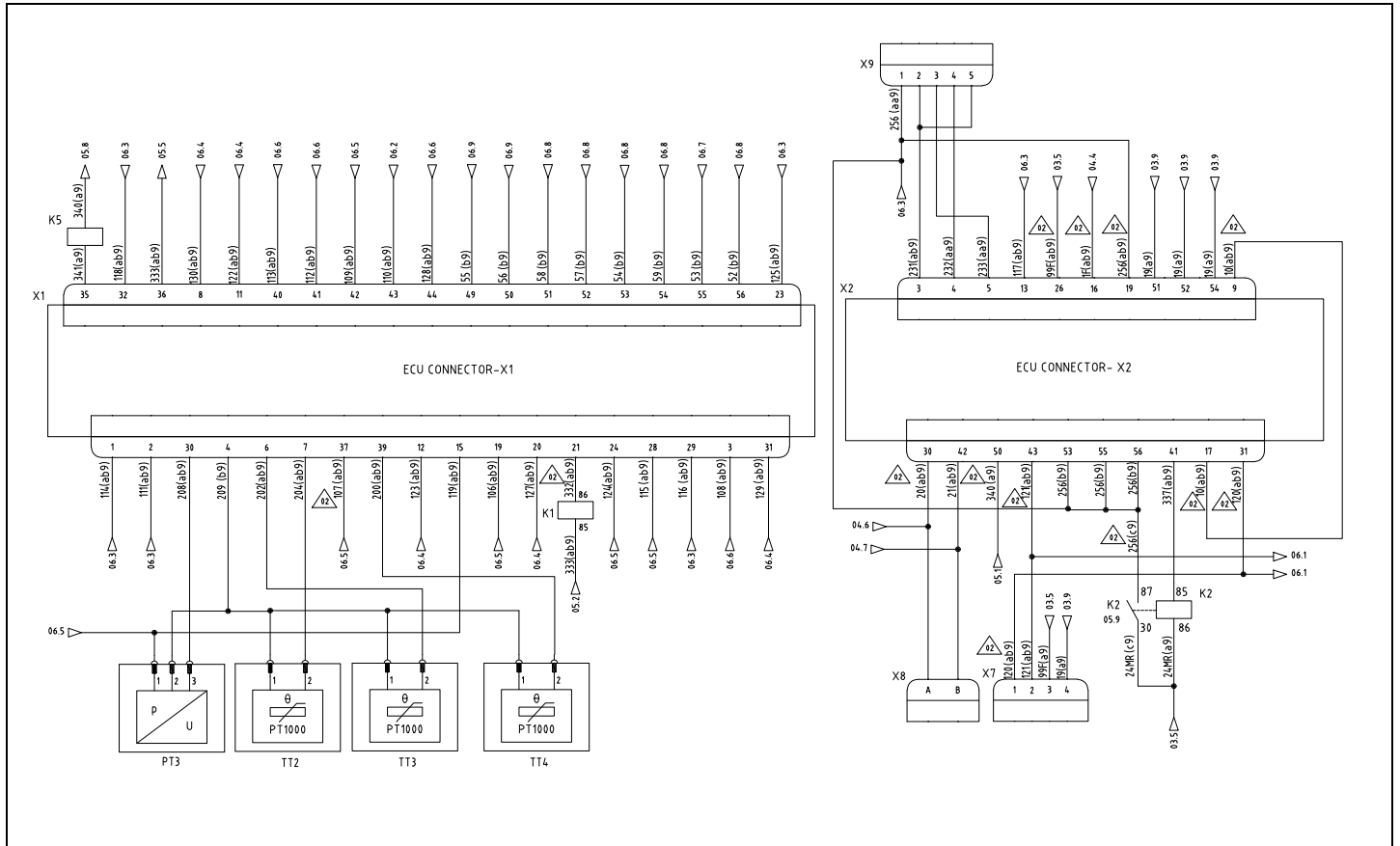

CIRCUIT DIAGRAM - 9822 1111 48-06

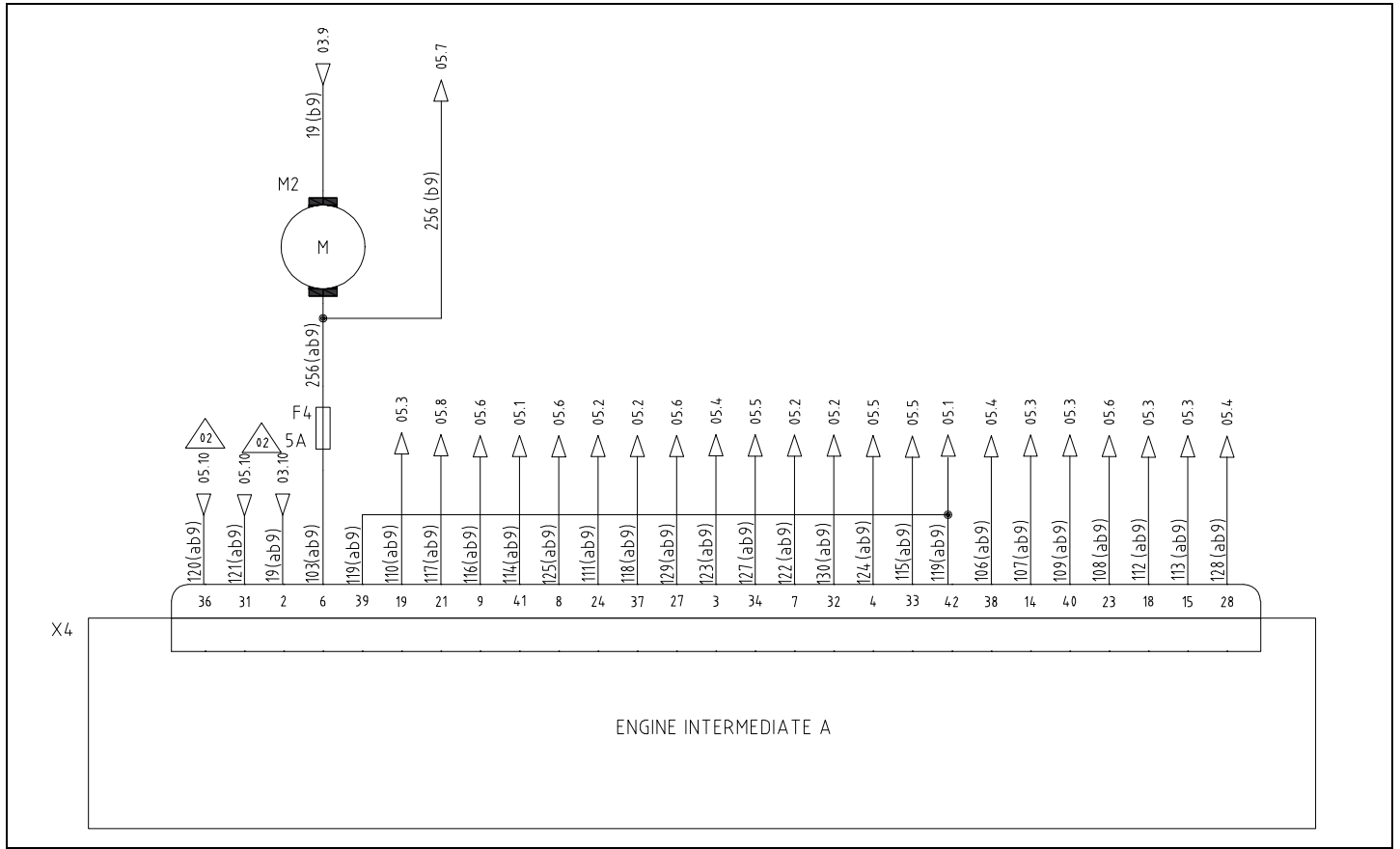

CIRCUIT DIAGRAM - 9822 1111 48-07

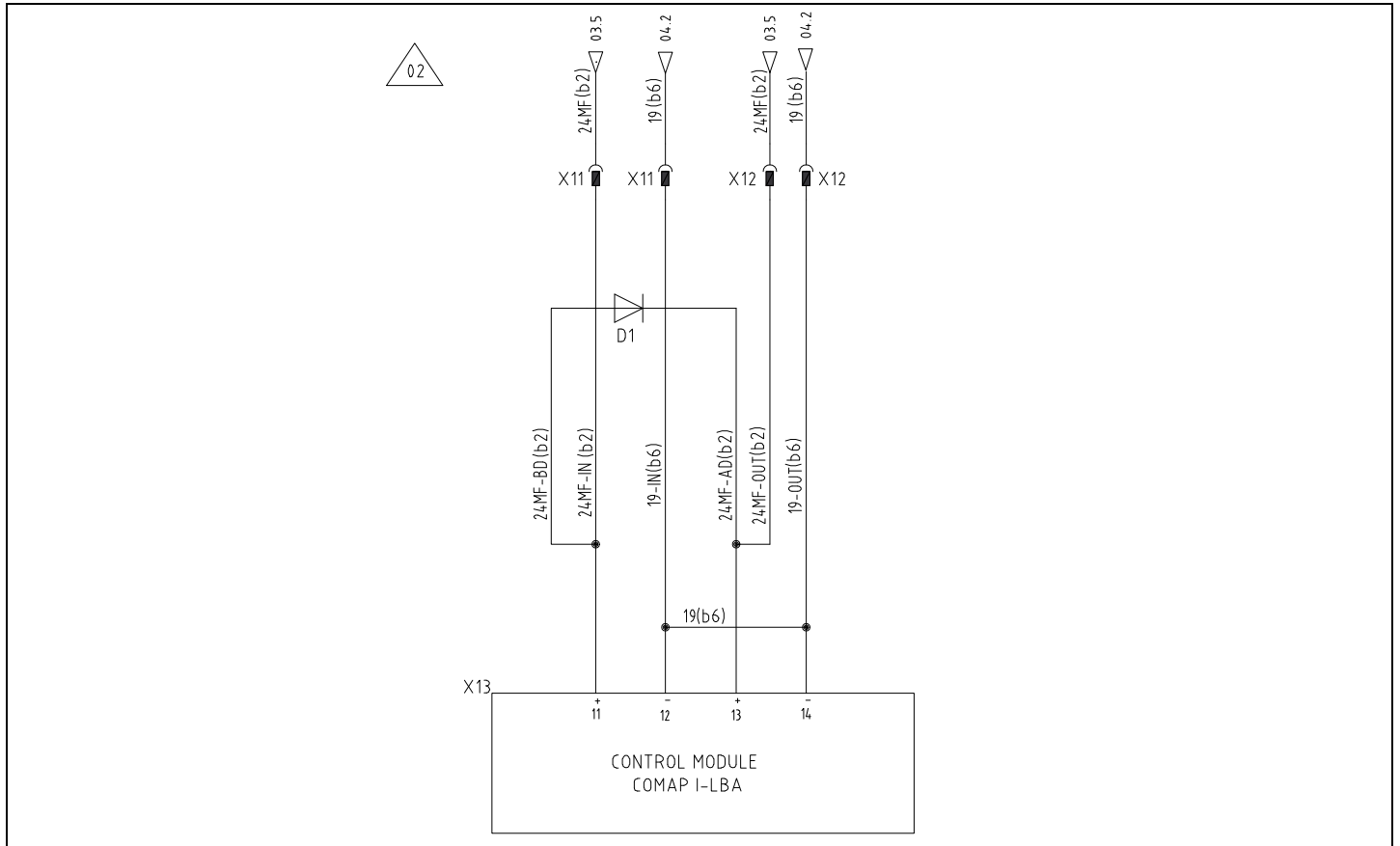

Weight

Weight ready to operate	see Dataplate
-------------------------	----------------------

Air outlet

Air outlet valves	3 x 3/4, 1 x 1 1/2"
-------------------	---------------------

Wheels

Tyre pressure	bar	2.7
	psi	39
Wheel bolt torque	Nm	85
	lbf.ft	63

Dataplate

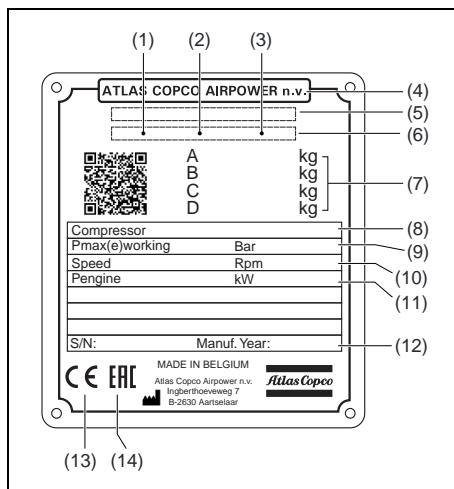

- 1 Company code
- 2 Product code
- 3 Unit serial number
- 4 Name of the manufacturer
- 5 EEC or national type approval number
- 6 Vehicle identification number
- 7 Undercarriage
 - A** Maximum permitted total weight of the vehicle
 - B** Maximum permitted load on the towing eye
 - C** Maximum permitted load on axle (or front axle on dual axle units)
 - D** Maximum permitted load on rear axle (on dual axle units)
- 8 Model
- 9 Working pressure
- 10 Speed
- 11 Engine power
- 12 Manufacturing year
- 13 CE mark in accordance with Machine Directive 89/392 EC
- 14 Register number or number of notified body

Disposal

GENERAL

When developing products and services, Atlas Copco tries to understand, address, and minimize the negative environmental effects that the products and services may have, when being manufactured, distributed, used and disposed.

Recycling and disposal policy are part of the development of all Atlas Copco products. Atlas Copco company standards determine strict requirements.

Material selection, substantial recyclability, disassembly possibilities and separability of materials and assemblies are considered, as well as environmental perils and dangers to health during the recycling and disposal of the unavoidable rates of non-recyclable materials.

Your Atlas Copco compressor consists for the most part of metallic materials, that can be remelted in steelworks and smelting works and are therefore almost infinitely recyclable. The plastic used is labelled; sorting and fractioning of the materials for recycling in the future is foreseen.



This concept can only succeed with your help. Support us by disposing professionally. By assuring correct disposal of the product you help prevent possible negative consequences for environment and health as a result of inappropriate waste handling.

Recycling and re-usage of material help preserve natural resources.

DISPOSAL OF MATERIALS

Dispose of contaminated substances and material separately, in accordance with locally applicable environmental legislation.

Before dismantling a machine at the end of its operating lifetime drain and dispose of all fluids of according the applicable local disposal regulations.

Remove the batteries. Do not throw batteries into the fire (explosion risk) or residual waste. Separate the machine into metal, electronics, wiring, hoses, insulation and plastic parts.

Dispose of all components in accordance with applicable disposal regulations.

Remove spilled fluid mechanically; pick up the rest using an absorbing agent (for example sand, sawdust) and dispose of it in accordance with applicable local disposal regulations. Do not drain into the sewage system or surface water.

DIRECTIVE 2012/19/EU OF THE EUROPEAN PARLIAMENT AND OF THE COUNCIL ON WASTE ELECTRICAL AND ELECTRONIC EQUIPMENT (WEEE)

This equipment falls under the provisions of the European Directive 2012/19/EU on waste electrical and electronic appliances (WEEE) and may not be disposed as unsorted waste.



The equipment is labelled in accordance with the European Directive 2012/19/EU with the crossed-out wheel bin symbol.

At the end of life-time of the electric and electronic equipment (EEE) it must be taken to separate collection.

For more information check with your local waste authority, customer center or distributor.



Scan the QR code to access into the Atlas Copco Spare Part list (ASL).



XATS 138 PE



XAHS 108 PE



XATS 250 PE