

YOUNGMAN

INNOVATIVE WORK AT HEIGHT SOLUTIONS

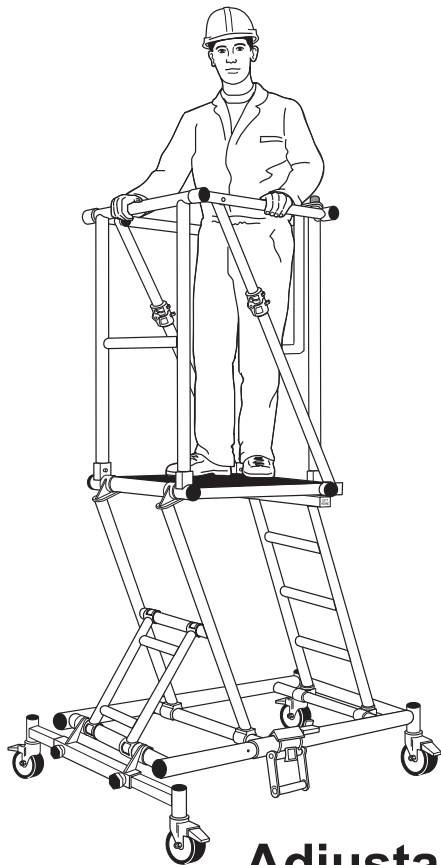

Adjusta-Minit

Adjustable Height
Mobile One Man Work Station

USER GUIDE

Safety First

IMPORTANT: Never use the work station until you have fully read and understood this User Guide and the work station has been properly set up using the information it contains.

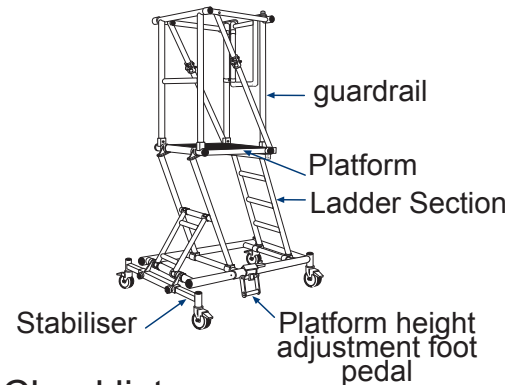

Safety Checklist

Is the workstation in good condition
(see Equipment Care & Inspection sections)



The total load (1 person plus tools & materials)
should not be more than 150kg



The 4 castors are pointing outwards and the
wheel brakes are locked



The guardrail is up and both diagonals are
locked



The work station is on flat, level, dry and firm
ground



The work station is correctly positioned to
avoid over reaching



The platform is at the correct height and the
foot pedal safety catch is locked



The stabilisers are fully extended and the
stabiliser locking handles are tight



The safety gate is shut and locked, once you
are on the platform



Equipment care

- Every time, before you use the work station, carry out the 6-point inspection detailed in the following section.
- Never use the work station if any part is damaged or shows signs of excessive wear. Only use this piece of equipment for its intended purpose, as a work station.
- Store the work station somewhere clean, dry and safe. The work station may be stored in the raised or lowered position.
- Keep the work station clean, especially the plywood platform and the treads of the ladder section. This is easier if you clean it regularly.
- Do not use excessive force to operate the work station mechanisms.

6 Point inspection procedure

1 Check all 4 castors are secure and the fixing bolts are tightened correctly.



2 Check all 4 wheel brakes operate and lock the wheel and the castor rotation.



3 Check the tubes and aluminium components of the workstation. There should not be any cracks or excessive dents or distortion.



4 Check there is free movement of the telescopic base section and all the hinge points of the work station.



5 Check the plywood platform. There should not be excessive contamination, cracking, holes or damage including any missing or damaged rivet fixings.



6 Check the following work station locking mechanisms are operating and locking correctly: guardrail diagonal centre locks, guardrail safety gate lock, foot pedal interlock, foot pedal safety catch.



Safety First

Every Time You Use The Workstation

- 1 ALWAYS** carry out a Risk Assessment for each job before you start work, to ensure the work station is the appropriate method of access
- 2 ALWAYS** check the workstation safety check list and follow the instructions in this User Guide and the labels on the work station. There is a serious risk of injury if you do not follow all the instructions.
- 3 ALWAYS** check the work station for damage before you use it, and complete an inspection report if necessary.
- 4 ALWAYS** make sure that you use the work station on firm and level ground.
- 5 ALWAYS** try to position the front of the work station towards the work for maximum stability.
- 6 ALWAYS** wear appropriate protective equipment and work-wear including foot wear with a flat firm sole and a good grip
- 6 ALWAYS** take safety measures when working close to doorways, openings and other traffic paths, to prevent accidental collisions but never block an emergency exit, fire-path or other escape route.

- 7 ALWAYS** secure the work station to prevent unauthorised use.

When Using The Workstation;

- 1 NEVER** use this work station until you are sure you are competent in its use and physically able.
- 2 NEVER** overload the work station. The work stations maximum safe working load is 150kg. This includes any tools or materials.

Safety First

- 3 NEVER** allow more than one person onto the work station, at the same time.
- 4 NEVER** use the work station if any part is damaged or shows signs of excessive wear.
- 5 NEVER** move the workstation when a person is standing on it.
- 6 NEVER** over-reach or lean too far over the side of the work station.
- 7 NEVER** carry out jobs that require excessive sideways force. Forces should never exceed 10kg when working with the side of the work station towards the work. Excessive sideways forces may cause the work station to overturn or the wheels to slip.
- 8 NEVER** lean anything against the work station e.g. ladders, steps or materials.
- 9 NEVER** climb up outside of the guardrail.
- 10 NEVER** stand the work station on soft, loose, slippery, sloping or uneven ground.
- 11 NEVER** use the work station outside in adverse weather conditions e.g. strong winds, heavy rain.
- 12 NEVER** stand on the guardrails, boxes, stepladders or other objects on the platform, to gain additional working height.
- 13 NEVER** use the work station near power lines or other live electrical equipment.
- 14 NEVER** suspend the work station from another structure.
- 15 NEVER** use the work station as a method of gaining access to another structure or level.
- 16 NEVER** use the work station if you are feeling unwell or you have taken any alcohol, medication or other substance that may affect your ability to work safely.

Setting up

Castors

If castors are not already fitted, insert them into the underside of the frame and tighten the fixing bolt using a 19mm AF spanner. The bolt must be tightened to a torque of 40Nm.

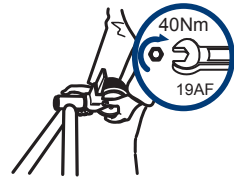

Moving and positioning the Work Station

When moving and positioning the work station, ensure all 4 wheel brakes are unlocked.



It is normally easier to wheel the work station around if you raise the guardrail. The workstation weighs 38kg so you may need help if you need to lift it (e.g. in and out of a vehicle)

IMPORTANT: Never move and position the work station when anyone is standing on the platform. Remove any tools or materials from the platform before moving the work station. Position the front of the work station towards the work, whenever possible, for maximum stability.

Raising the guardrail

- 1** Raise the guardrail by lifting the top rail where indicated **LIFT HERE.**

- 2** Check that centre catches on **both** guardrail frame diagonal braces have locked as shown.

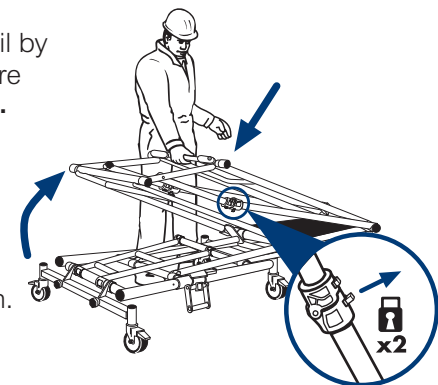

IMPORTANT: Never climb on to the workstation until you have raised and locked the guardrail and locked all 4 wheel brakes with the castors pointing outwards.

Setting up

Setting the stabilisers

1 Release the stabiliser locking handles on both sides of the workstation

2 Slide the stabilisers out to the fully extended position and tighten the locking handles

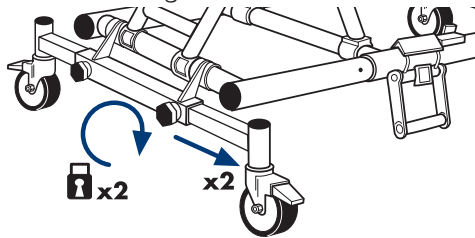

IMPORTANT: Never climb on to the workstation without fully extending the stabilisers and tightening the locking handles

Raising and lowering the platform

When the work station has been positioned, and the stabilisers extended, the platform height may be adjusted to a suitable working position. The work station has 4 height positions:

Height (m)	Position	Safe Working Height*
0.4 m	Fully lowered	1.90 m
0.8 m	2nd Position	2.30 m
1.025 m	3rd Position	2.525m
1.25 m	4th Position	2.75 m

Safe Working Heights are based on an approximate shoulder height of 1.5m above the platform. It is possible to work above this e.g. overhead when working on ceilings, but you should never over-reach or stand on the guardrails, or anything placed on the platform, to gain extra height.

Setting up

IMPORTANT: Never attempt to adjust the height of the work station when anyone is standing on it. Remove any tools or materials from the platform before adjusting the workstation height.

To adjust the height of the platform:

1 If you have not already raised and locked the guardrail and extended the stabilisers (as described in the previous sections) do it now. If you intend to use the platform at the 0.4m height position, then proceed to instruction number 9 in this section.

2 Lock the wheel brakes of the 2 back castors with wheels pointing outwards. Leave the front wheel brakes unlocked.

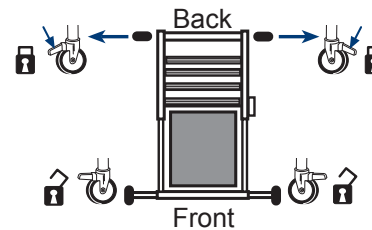

3 Check that the foot pedal safety catch is unlocked.

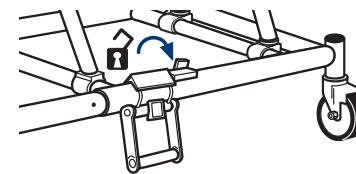

4 Hold onto the work station by the lifting handle, labelled Lift Here. Place the sole of your shoe on the bar of the platform foot pedal, with your heel on the ground. Push the bar of the foot pedal inwards to disengage the platform height locking mechanism.

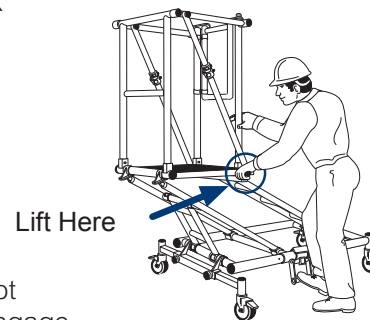

Setting up

5 Using your foot to keep the pedal pressed inwards, move the lifting handle upwards or downwards to raise or lower the platform.

IMPORTANT: Do not let go of the platform and let it drop under its own weight as this could cause damage to the work station. Hold on to the Lifting Handle and raise or lower it with care.

6 The telescopic tubes in the base of the work station are marked with holes to indicate the 0.8m and 1.025m platform height positions. At 1.250m positions, the end stops on the telescopic tubes position the platform.

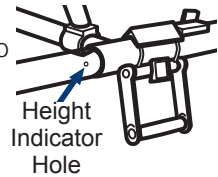

When the appropriate height mark on the telescopic tube is aligned with the end of the base tube release the foot pedal to engage the platform height locking mechanism. You may need to raise or lower the platform slightly so that the spring loaded locking mechanism can engage and lock.

7 Engage the foot pedal safety catch to the locked position by rotating it behind the foot pedal plate.

IMPORTANT: The mechanism is fully engaged and locked only when the safety catch has been rotated to the locked position as shown. Never climb onto the work station without checking the locking mechanism has fully engaged and the safety catch is locked.

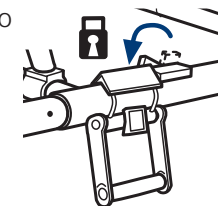

8 Lock the wheel brakes of the 2 front castors with wheels pointing outwards.

9 IMPORTANT: Never climb on to the workstation without locking all 4 wheel brakes with the wheels pointing outwards. Lock all 4 wheels brakes as shown in the diagram below.

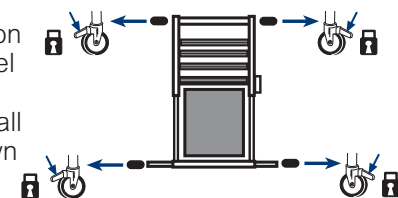

Setting up

Climbing on and off the platform

1 Lift the safety gate upwards to clear the locking pin and open it outwards until it locates in the open position.

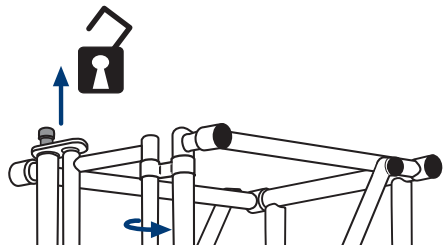

2 Using the opened safety gate as a handrail, carefully climb up the ladder section of the work station and onto the platform.

3 Lift the safety gate up to clear the locating pin. Swing the gate to the closed position. Lift the gate upwards and inwards so that the hole in the locking plate engages over the locking pin. Let the gate down onto the locking pin.

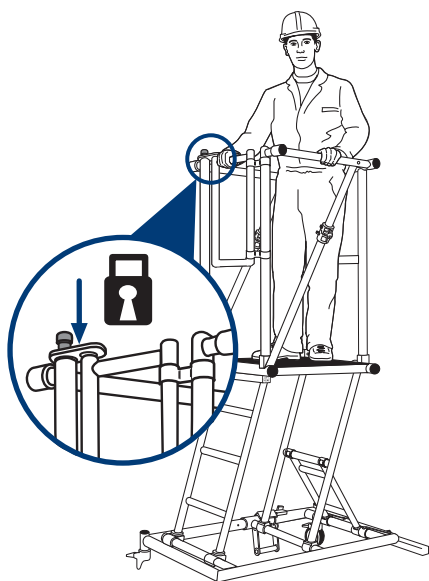

Setting up

4 When climbing off the platform, release the locking plate by lifting the safety gate and then swing it open until it clicks into the open position.

5 IMPORTANT: Facing the platform, climb down the ladder section using the opened safety gate as a handrail. Never work when standing on the ladder section of the work station.

Packing up the Work Station

1 The procedure for packing up the workstation is the reverse of setting up, as described below.

2 Release the wheel brakes on the front wheels.

3 Release the foot pedal safety catch and use the foot pedal to release the platform height locking mechanism. Lower the Platform to the lowest position.

IMPORTANT: Do not let go of the platform and let it drop down under its own weight as this could cause damage to the work station. Hold onto the Lifting Handle and lower it with care.

4 Release the stabiliser locking handles and push the stabilisers inwards to the closed position. Re-tighten the locking handles

5 Release the wheel brakes on the rear wheels.

6 It is normally easier to wheel the work station around with the guardrail raised.

7 When you are ready to fold up the guardrail, make sure the safety gate is closed and locked. Unlock the centre catches on both guardrail diagonals and then holding it at the LIFT HERE position, lower the guardrail to the folded position.

YOUNGMAN
INNOVATIVE WORK AT HEIGHT SOLUTIONS

For further information about this product or any other products and services, please contact :

Youngman Group Ltd
The Causeway, Maldon,
Essex, CM9 4LJ,
United Kingdom

t +44 (0)1621 745900
f +44 (0)1621 859845
e sales@youngmangroup.com

youngmangroup.com