

**T-ZERO** PRO

**POWER & INNOVATION**

# LIGHTING TOWER X-SOLAR HYBRID

A combination of **power** and **savings**



[www.sunbeltrentals.co.uk](http://www.sunbeltrentals.co.uk)

The above specification and information have been provided to Sunbelt Rentals by the manufacturer of the relevant item and are the manufacturer's own technical data and specifications. Sunbelt Rentals shall have no liability (howsoever arising) in respect of and does not confirm the accuracy of any information set out above. The manufacturer's specification means any description or specification included in any catalogues, brochures or other materials published by or on behalf of the manufacturer from time to time.

# T-ZERO<sup>PRO</sup>

## POWER & INNOVATION

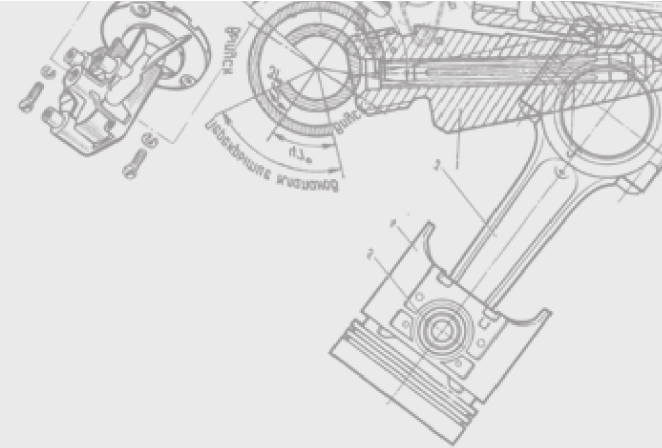

# LIGHTING TOWER X-SOLAR HYBRID



Tremendous reduction in fuel, noise and CO2 emissions!

4 unit for truck

illuminated area 2400 sqm

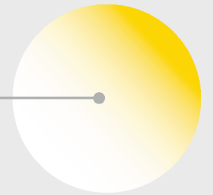

### APPLICATIONS

- Construction & work sites
- Rural & hard to reach areas
- Special events
- Parking areas
- Military applications
- Gas, oil & mining operations



technical data	X-SOLAR Hybrid
Illuminated area	2400 sqm
Batteries	8x 6 Vdc 400ah AGM
Battery pack	24 Vdc 800ah AGM
Running time from battery	70 h
Overall Running time	3000 h
Engine	KUBOTA Z482
Dimensions mm	3800X1656X2694
Mast	hydraulic
Weight	1890 kg

MV | Design



[www.sunbeltrentals.co.uk](http://www.sunbeltrentals.co.uk)

The above specification and information have been provided to Sunbelt Rentals by the manufacturer of the relevant item and are the manufacturer's own technical data and specifications. Sunbelt Rentals shall have no liability (howsoever arising) in respect of and does not confirm the accuracy of any information set out above. The manufacturer's specification means any description or specification included in any catalogues, brochures or other materials published by or on behalf of the manufacturer from time to time.