

**RAPTOR**  
FROM **TOWMATE**



**LAYSAFE**



# 5 WAYS LAYSAFE IS A SOLUTION TO YOUR NIGHTMARE

1. LaySafe reduces the major health & safety issues around installing coiled pipe
2. LaySafe saves on lost days due to injuries caused by coiled pipe
3. LaySafe makes coiled pipe more efficient to install than sticks, saving up to £4,600 per 100m length
4. LaySafe reduces waste
5. LaySafe means your teams are more effective



## HOW DOES IT WORK?

- Works by feeding the pipe through a series of rollers at the rear of the trailer - simple yet effective.
- Removes the stored energy and leaves the pipe in an inert, safe state.
- Helps better stabilize and control the pipe inside the trailer.

## WHAT DOES IT DO FOR YOU?

### BETTER FOR YOUR EMPLOYEES

- **Energy removed from the pipe** - eliminates health and safety risk to employees and the public
- **Reduced manual handling and lifting for operatives**

### BETTER FOR THE ENVIRONMENT

- **Reduced CO2 emissions.**
- Reduction in excavations.
- **Reduction in number of welds needed**
- Minimised potential for utility damages

### BETTER FOR YOUR CLIENTS

- **Faster than "stick" methods.**
- Connection work completed quicker
- **Guaranteed high-quality installation**

**NWG LIVING WATER SAYS** "LaySAFE now allows us to lay pipes far much more efficiently, and more importantly eliminates the historic Health and Safety risks associated with pulling coiled pipes from trailers. We provided feedback in the early development of the product, and used it in early trials throughout 2021. LaySAFE will go onto be a huge benefit to the whole pipe laying industry."



### ENGINEERED TO WORK

- **Designed for the application.**
- Doesn't cause excessive stress or ovalisation of the pipe.
- **Doesn't require complex systems**



### SAVES TIME & MONEY

- More than **10 x** faster than using sticks
- **Saves up to £4,600 per 100 metres** of pipe installed.



### A COMPLETE PACKAGE

- Available as a complete package on our Raptor 180 pipe trailer
- The perfect solution for gas, utilities and water industries

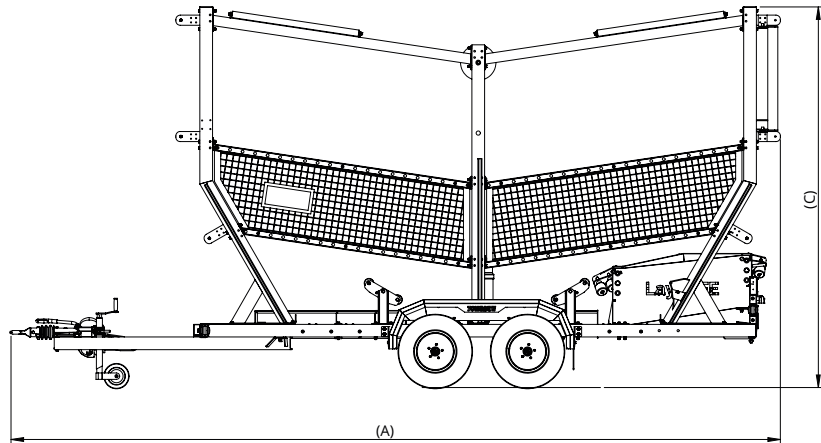
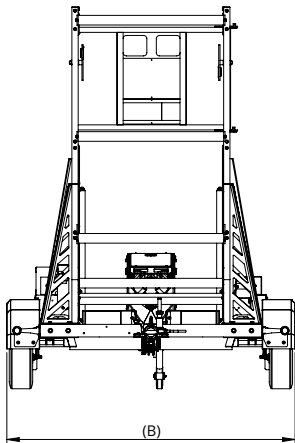

## RAPTOR LAYSAFE PIPE TRAILER SPECIFICATIONS

### CAPACITY

Gross (KG)	2600
Payload KG (standard spec)	1580
Unladen Weight KG (standard spec)	1020

### DIMENSIONS

(A) Overall Length (mm)	6085
(B) Overall Width (mm)	2280
(C) Overall Unladen Height (mm)	3010
Maximum Coil Outside Diameter (mm)	4080
Maximum Coil Width (mm)	1040

### RUNNING GEAR

Axles	2
165 R13 8 Ply Wheel & Tyre Assembly	●
50mm Locking Head	No Cost Option
40mm Eye Coupling	No Cost Option
WheelSentry®	○

### BED & REAR LOADING

LaySafe	●
---------	---

### ADDITIONAL OPTIONS

Hop Up Steps w/ Gripdeck Infills	○
----------------------------------	---

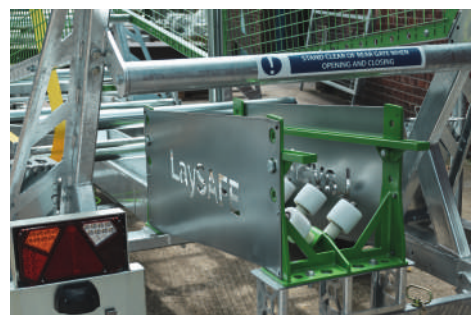



**HEAD OFFICE:**

Towmate Trailers Ltd,  
Whitehall Road, Colchester  
Essex,  
CO2 8WA

**T:** 01206 484530

**E:** [sales@towmatetrailers.co.uk](mailto:sales@towmatetrailers.co.uk)

[www.towmatetrailers.co.uk](http://www.towmatetrailers.co.uk)

