

ALL DIMENSIONS IN mm U.O.S.

DO NOT SCALE DRAWING

SPECIFICATION

<u>UNLADEN WEIGHT</u>	:-- 730 KGS
<u>GROSS WEIGHT</u>	:-- 3500 KGS
<u>TOW EYE LOAD</u>	:-- 150 KGS (MAX)
<u>AXLE LOAD</u>	:-- 3350 KGS (MAX)
<u>PAYLOAD</u>	:-- 2770 KGS
<u>MAX REEL DIA</u>	:-- 2500 mm
<u>MIN REEL DIA</u>	:-- 1060 mm
<u>MAX REEL WIDTH</u>	:-- 1280 mm (WITH COLLARS)
<u>SPINDLE DIA</u>	:-- 76 mm
<u>TYRES & WHEELS</u>	:-- 215/75 R17.5
<u>DRAWBAR</u>	:-- FIXED HEIGHT FITTED 50 mm EYE X 600 mm HIGH
<u>BRAKES</u>	:-- 300 x 80 A.R. OVERUN INERTIA
<u>LIGHTS</u>	:--12 VOLT-TYPE APPROVED SYSTEM WITH 13 PIN PLUG
<u>CONSTRUCTION</u>	:-- ALL STEEL WELDED
<u>DRUM LIFT</u>	:--VIA HAND PUMP C/W LIFT BALANCE VALVE MECHANICAL LOCK WHEN DRUM RAISED FOR TRAVEL
<u>PAINT</u>	:-- FULL GLOSS BS 4800-08E51 YELLOW UNLESS OTHERWISE STATED

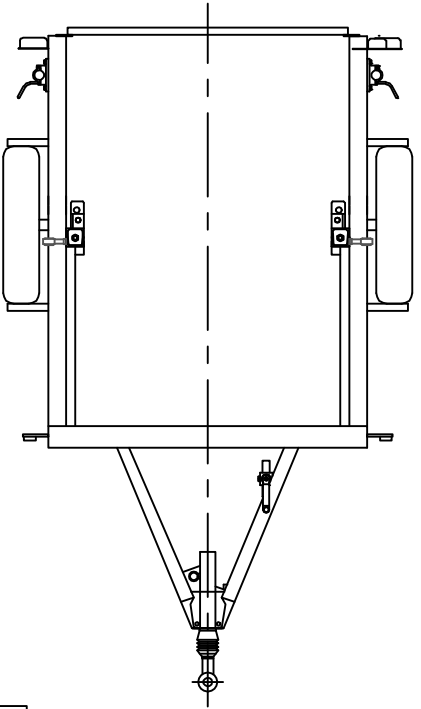
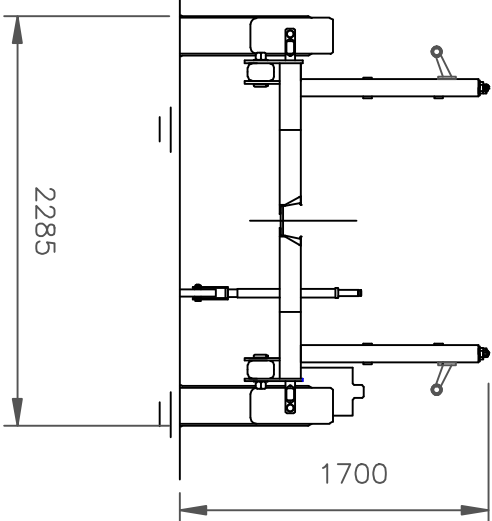
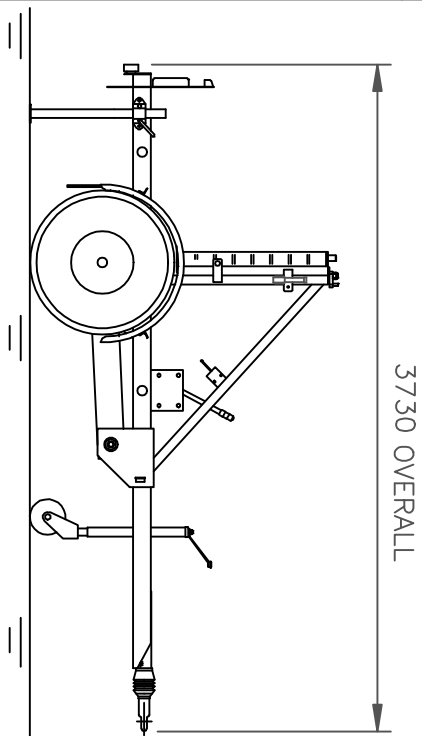

ALL DIMENSIONS QUOTED ARE APPROXIMATE ONLY AND MAY VARY DUE TO MANUFACTURERS TOLERANCES

APPROVAL No e11*2007/46*0733*00

REV	AMENDMENT	DATE	NAME

	
<p>S.E.B. INTERNATIONAL LTD. UNITY ROAD, LOWMOOR ROAD INDUSTRIAL ESTATE, KIRKBY IN ASHFIELD, NOTTS.</p>	
<p>TITLE CD70-ECWVTA TYPE APPROVED FIXED HT GA</p>	
NAME	DRG No.
RM	CD70 FIXED HT
DATE	SCALE
25/10/2012	