



Grip Factory Munich
YOUR INNOVATIVE PARTNER FOR CAMERA SUPPORT

GF-16

Crane System

Instruction Manual

Valid: March 2015

Grip Factory Munich GmbH
Fürholzener Straße 1
85386 Eching bei München
Germany

Tel.: +49 (0) 89 319 0 129-0
Fax: +49 (0) 89 319 0 129-9
e-Mail: info@g-f-m.net
<http://www.g-f-m.net>

Contents:

SAFETY GUIDELINES	2
Assembly Procedure – GF-16.....	3
For all versions:	3
The GF-16 Adjustable Mounting Column:.....	4
Pivot Section.....	5
General Assembly	5
Version 1	7
Version 2	8
Rigging system	9
General:.....	9
Rigging Harness Assembly:	9
Parallelogram Supports	10
Version 3	11
Version 4	13
Version 5	15
Version 6	17
Version 7	19
Version 8	21
Version 9	23
Version 10	26
Version 11	29
Version 12	32
Version 13	35
Version 14	38
Version 15	41
Remote Head Mount.....	43
Balancing the crane arm	44
Deloading:	44
General Safety.....	44
Positioning the Adjustable Mounting Column.....	45
GF-16 Camera Crane and Dolly Dimensions.....	46
Dolly weight	46
Accessories for GF-16 Crane platform weight list	47
Transport trolley for the GF-16 Crane	48
Maintaining the Adjustable Column	49
Dismantling the column:.....	49
Maintenance	50
Regular Inspections	51
EC Declaration of Conformity	52

SAFETY GUIDELINES



The set-up instructions must be read and understood before set-up or operation. The crane may only be assembled in accordance with the manufacturer's instruction manual. The manufacturer's technical specifications and limits (maximum rated loads of each version) must be adhered to at all times and in no way exceeded.

The GF-16 Crane may only be set-up or operated by trained and experienced personnel. To assemble the crane at least two men are needed. To avoid misuse by untrained personnel, the crane should be dismantled when not in use or under supervision.

For further information on the qualifications required for test personnel please refer to BGV 1, §33 and §34.

The crane may not be set-up or operated under the influence of alcohol, drugs or any other intoxicating substances. The respective protective clothing e.g. gloves, should be worn.

The manufacturer accepts no liability for damages or injuries for incidents or accidents occurring due to negligence by the crane operator or misuse of the crane or disregarding the instruction manual.

Before assembling the crane ensure that the ground surface is stable and cannot give way. The ground surface must be stable enough to support at least 2300 kg/m² = 5060 lbs/ sq yard.

Crane operation is only allowed with solid tires. Use with pneumatic wheels is not allowed. Before and while using the crane the wheels should be inspected.

Whether operating or moving the crane on track or on a solid ground surface it is essential that the track or surface is completely level, stable and free from obstructions. If necessary, level the crane with the provided levelling legs.

When operating the crane on track, ensure that the track is level, properly laid and constructed. The correct underlay must be used to ensure that the track and underlay are secured against moving, slipping and collapse. Ensure that the underlay provides the specified support and stability. Use the manufacturers mounting ramp when driving on or off track.

Operation on curved track is strictly forbidden.

Use of the crane on insert vehicles, camera cars or any motorised vehicle is not allowed. The manufacturer accepts no liability for damages or injuries for incidents or accidents occurring due to use of the crane on insert vehicles, camera cars or any other motorised vehicles.

Changing weather conditions should be taken into consideration. The crane must be taken out of operation before the operational wind speed reaches 25km/h (15.6mph). For this purpose see page 44.

The complete lift and panning range of the GF-16 Crane must be kept clear of obstructions at all times. A safety clearance of 1m / 3' 3" must be observed on all sides of the crane during operation. Only authorised, trained and experienced personnel are allowed to operate the crane. In the interest of safe crane operation, when operating or moving the crane, abrupt, sudden movements of the crane should be avoided. An element of risk remains by people moving in the operational range of the crane. The crane operator has to be trained on that and is only allowed to operate the crane in safe range.

The crane may not be used in the direct vicinity of high voltage power cables. To avoid accidents due to misuse in the vicinity of high voltage power cables, Safety Guidelines (especially VBG 1 and 4) as well as VDE regulations (especially 0105 part 100) must be adhered to. If the nominal voltage cannot be determined, a minimum clearance of 5m / 16ft must be kept at all times. Failing to do so can cause fatalities.

Personnel on board the crane's platform must use safety belts at all times. They should not make any sudden, abrupt movements or lean out over the side of the platform. No loose objects may be stored or placed on the crane platform.

Before the counterweights are removed from the bucket, ensure that the platform is resting on the ground or alternatively supported by an appropriate stable underlay. Gradually remove the counterweights before personnel leave the platform or before the remote head or camera are dismantled. It's not allowed to put extra weights on top of the counterweight bucket or any other part of the crane!

For safety reasons only original accessories manufactured by GFM may be used with the crane.

Assembly Procedure – GF-16

General description:

The GF-16 is a mobile crane-system for mounting cameras in a stationary ground position or for movement on track.

It can be operated manually from the ground and can be panned in all directions either with a remote-bracket or a 1 to 2 person platform. In accordance to the safety guidelines the crane is only allowed to be used on solid, level and stable ground. While using it stationary the levelling legs have to be used.

The crane operation from the ground is managed by at least one experienced, trained and authorised personnel from the hand grips on the counterweight bucket.

Operation of the crane is only allowed within the limits and guidelines mentioned in the instruction manual. The allowed payloads of each version are clearly shown on the counterweight-bucket (workplace of the crane operator).



Attention: Before and during assembly observe the Safety Guidelines.

For all versions:

1. Secure the base dolly so that it cannot move or roll. Lock all wheel brakes. Move the steering rod towards the centre of the dolly or remove it so that the set-up personnel do not trip over it.



The levelling legs should be used to level the base when stationary

The GF-16 Adjustable Mounting Column:

- Bolt the Adjustable Mounting Column to the base dolly. Make sure that the locking bolts are locked securely.

Tip: The carrying handles on the bazooka should point to the left and right of the dolly.



- Connect the 4 Adjustable Stabilizing Rods between the base and the column by securing each one with a locking pin at the top and bottom of each rod.



Important:

When adjusting the height of the column make sure that the 4 Adjustable Stabilizing Rods can move freely and that they are not restricted in travel. The Rod Locking Pin found in the middle of each rod must be removed when adjusting the height and reinserted only when the column is in the required position.

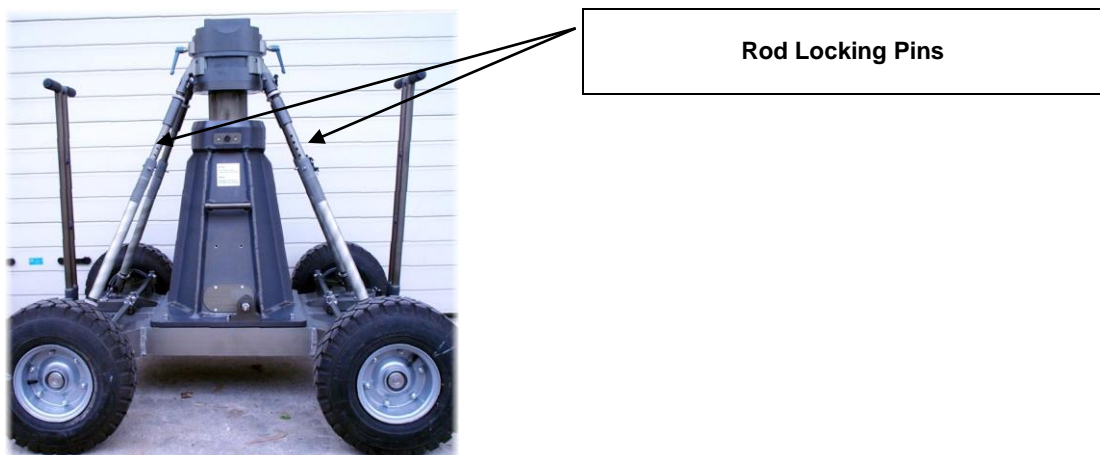

Pivot Section

4. Located on the middle section are 2 tilt friction locks which may be used to lock the tilt during set-up. Set the pivot arm at 90° to the centre post and lock the friction locks which can be found on the left and right hand side of the middle section.

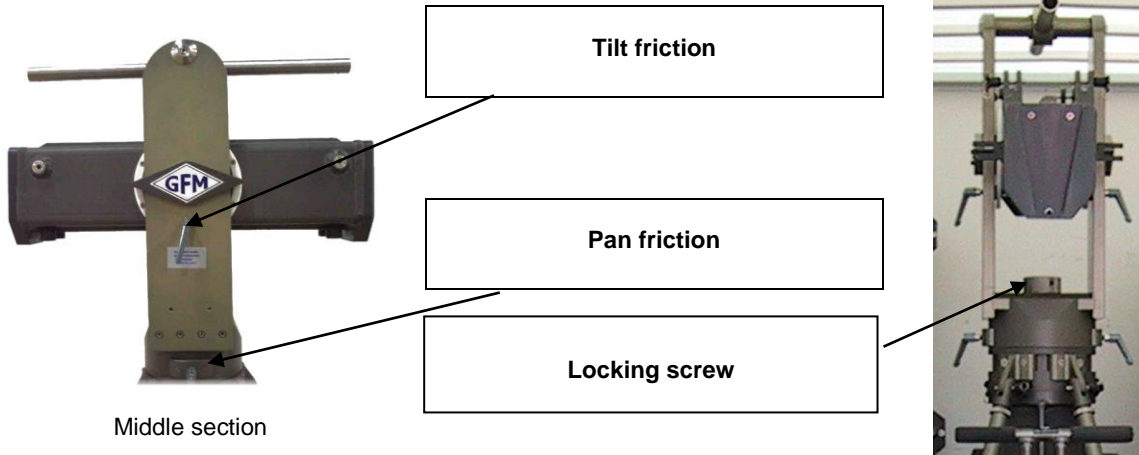

5. Mount the middle section on the mounting column. Lock the locking screw tightly.
Tip: A 12mm Allen key can be found in the mounting column's handle to be used as a lever.



Attention: Install the middle section to the rotate able bearing of the column with positive locking. It fits properly only in one position.

General Assembly

6. Connect extension number 1 to the middle section. Slip the connection flanges into each other and secure with the provided safety pin.
Tip: To avoid the sections jamming or getting stuck make sure that the sections are joined parallel. Using a small amount of lubricant also helps. We suggest rubbing the joints with an oiled rag prior to assembly.



Mounting an extension arm



Securing the arm with a safety pin

7. Connect the 192cm / 6'3" counterweight bucket extension to the middle section. Slip the connection flanges into each other and secure with the provided safety pin.
 8. Connect the 192cm / 6'3" parallelogram rod to the parallelogram connection on the middle section and secure it with the provided safety pin.
 9. Release the angle adjuster located at the end of the 192cm / 6'3" section by removing the safety pin from the side of the angle adjuster.



Attention: Pinch point

Tip: With the removed safety pin the connection between counterweight bucket and angle adjuster has to be secured.

10. Connect the parallelogram rod to the rod on the angle adjuster and secure it with the provided pin.

Tip: The angle adjuster has an integrated leveller. By turning it, the vertical plate on the angle adjuster can be set to a perfect right angle. Correct setting of the angle adjuster enhances the crane's balance.



Angle adjuster connected to parallelogram rod



Connecting the locking pin

11. Support the mounted counterweight section with a suitable support stand or rostrum.
12. Connect the lower section of the 2 part counterweight bucket to the angle adjuster located on the rear of the counterweight bucket extension. Slip the connection flanges into each other and secure with the removed safety pin from the side of the angle adjuster.

Tip: Do not load weights until the rigging system is mounted (see page 9).

Tip: To mount the top bucket just put it on top of the lower one and screw it either with the provided safety pins or the captive screws. (See the GF-16 Specifications at which version the Top Bucket is needed)

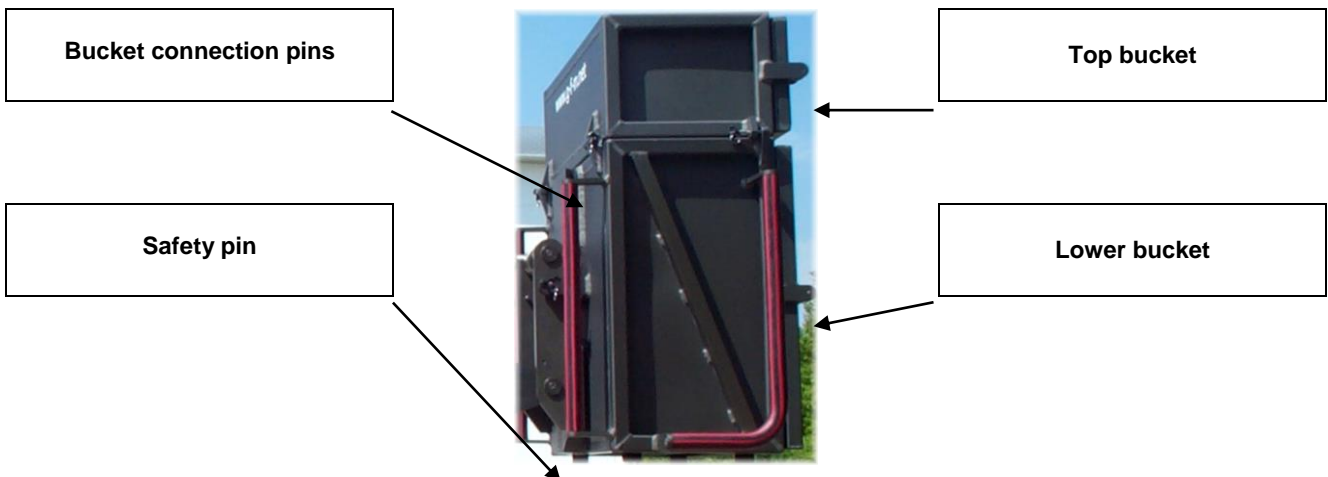

The assembly procedure up to this point is the same in all versions.

To assist the set-up procedure and to reduce the risk of accidents it is recommended to use set-up support stands or rostrums to support the crane arm during set-up and breakdown.

Version 1

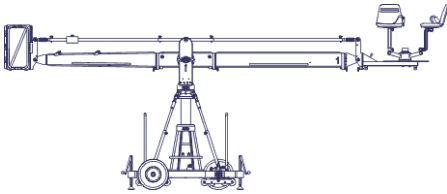

Front extension arms required	1 x 200 cm / 6' 6"
Rear extension arm required	1 x 192 cm / 6' 3"
Lift range	420 cm / 13' 9"
Maximum Euro-adapter height	423 cm / 13' 10"
Lift capacity (working load) 2 pers. + accessories	250 kg / 550 lbs
Counterweight required for max. load	274 kg / 602 lbs
Counterweight required to balance empty arm	8 kg / 17 lbs
Crane weight (excluding dolly and weights)	661 kg / 1457 lbs
Dolly weight (unit weights see page 46)	244 kg / 536 lbs
Arm reach (pivot to camera head mount)	336 cm / 11'
Length of rear end (pivot to outside of bucket)	278 cm / 9' 1"

Continue from § 12, page 6

13. Connect the angle adjuster to the end of the 200cm / 6' 6" extension number 1. Release the angle adjuster by removing the safety pins from the side of the angle adjuster. Secure the angle adjuster to extension number 1 with a removed safety pin.

Tip: The angle adjuster has two sidewise safety pins. These are either used for the angle adjusters transport position or to secure the connections between angle adjuster and extension as well as angle adjuster and platform.

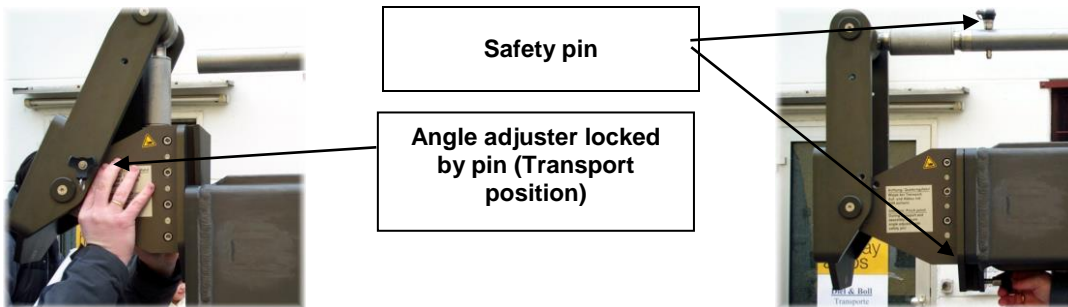

Mounting the angle adjuster

Securing the angle adjuster

14. Connect one of the 200cm / 6' 6" parallelogram rods to the rod connection located on the middle section and secure it the provided safety pin.
15. Connect the parallelogram rod to the rod connection on the angle adjuster and secure it with the provided safety pin.
- Tip:** The angle adjuster has an integrated leveller. By turning it, the vertical plate on the angle adjuster can be set to a perfect right angle. Correct setting of the angle adjuster enhances the crane's balance.
16. Connect the platform to the angle adjuster and secure with the removed safety pin from the side of the angle adjuster. Ensure that the platform is level.
17. Remove the support stand or rostrum supporting the counterweight bucket section.
18. Then unlock the tilt friction.

Before operation, all locking pins, locking screws etc should be inspected to ensure that all assembly sections are securely fastened.

Read "Balancing the crane arm" on page 44.

Version 2

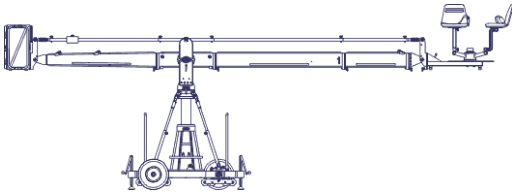

Front extension arms required	1 x 200 cm / 6' 6" + 1 x 100 cm / 3' 3"
Rear extension arm required	1 x 192 cm / 6' 3"
Lift range	575 cm / 18' 10"
Maximum Euro-adaptor height	501 cm / 16' 5 "
Lift capacity (working load) 2 pers. + accessories	250 kg / 550 lbs
Counterweight required for max. load	424 kg / 932 lbs
Counterweight required to balance empty arm	36 kg / 79 lbs
Crane weight (excluding dolly and weights)	678 kg / 1495 lbs
Dolly weight (unit weights see page 46)	244 kg / 536 lbs
Arm reach (pivot to camera head mount)	434 cm / 14' 2"
Length of rear end (pivot to outside of bucket)	278 cm / 9' 1"

Continue from § 12, page 6

13. Connect the 100cm / 3' 3" extension to extension number 1. Slip the connection flanges into each other and secure with the provided safety pin.

Note: The 100cm / 3' 3" section must be supported by a suitable support stand or rostrum.

Tip: To avoid the sections jamming or getting stuck make sure that the sections are joined parallel. Using a small amount of lubricant also helps. We suggest rubbing the joints with an oiled rag prior to assembly.

14. Connect a 200cm / 6' 6" parallelogram rod to the parallelogram connection on the middle section and secure it with the provided safety pin.

15. Connect the 100cm / 3' 3" parallelogram rod to the first parallelogram connection and secure it with the provided safety pin.

16. Connect the angle adjuster to the end of the 100cm / 3' 3" extension. Release the angle adjuster by removing the safety pins from the side of the angle adjuster. Secure the angle adjuster to the 100cm / 3' 3" extension with a removed safety pin.

Tip: The angle adjuster has two sidewise safety pins. These are either used for the angle adjusters transport position or to secure the connections between angle adjuster and extension as well as angle adjuster and platform.

17. Connect the 100cm / 3' 3" parallelogram rod to the rod on the angle adjuster and secure it with the provided safety pin.

Tip: The angle adjuster has an integrated leveller. By turning it, the vertical plate on the angle adjuster can be set to a perfect right angle. Correct setting of the angle adjuster enhances the crane's balance.

18. Connect the platform to the angle adjuster and secure with the removed safety pin from the side of the angle adjuster. Ensure that the platform is level.

19. Remove the support stand or rostrum supporting the counterweight bucket section.

20. Then unlock the tilt friction.

Before operation, all locking pins, locking screws etc should be inspected to ensure that all assembly sections are securely fastened.

Read "Balancing the crane arm" on page 44.

Rigging system

The rigging system must be used from Version 3 upwards.

General:

For versions using more than 3 x 200cm long sections (versions 7 to 15), a **double rigging system** must be mounted. During assembly, to support the arm and ensure that it does not dip, mount the lower rigging system as soon as crane arm sections 2, 3 or 4 (depending on version) are mounted. When the lower rigging is mounted and adjusted, only then add on section 4, 5 and 6 etc. As soon as the last section is mounted, then assemble the top rigging system.

Tip: Do not load weights until the rigging system is mounted.

Never use the crane with 2 or more than 2 x 200cm sections mounted without rigging.

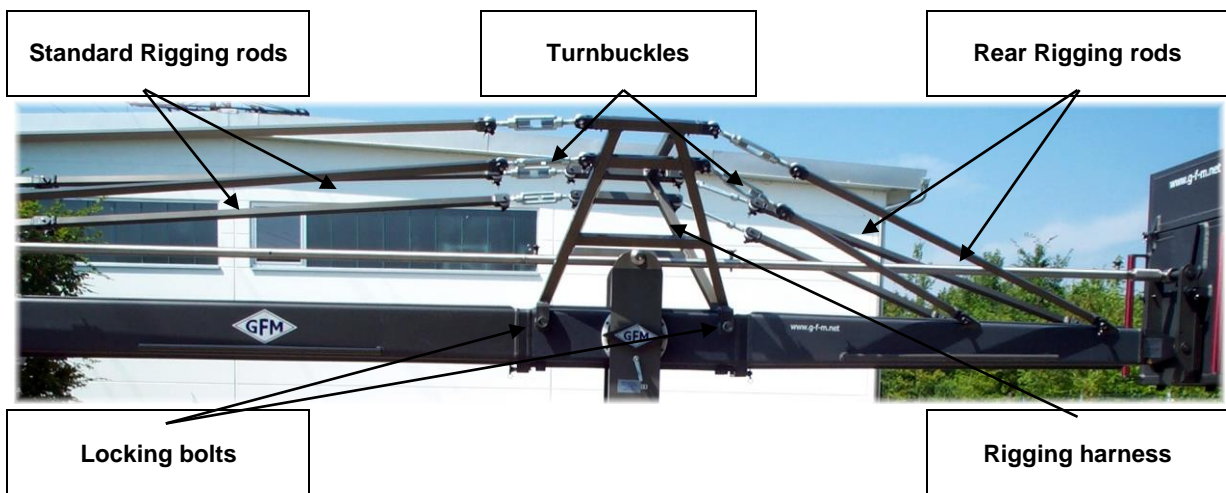

Rigging Harness Assembly:

1. Connect the rigging harness to both sides of the middle section and connect with the 2 cross bars. Then ensure that the 4 locking bolts are inserted and tightened fully to the Pivot Section. Ensure that the 4 locking pins securing the 2 cross bars are inserted fully.
2. Connect the turnbuckles to the rear rigging harness and in turn connect the 4 rear rigging rods to the 4 rigging connections on the counterweight bucket arm. Connect the 2 x 90cm rods to the lower turnbuckles and in turn to the inner connections on the rear section. Then connect the 2 x 150cm rods to the top turnbuckles and in turn to the outer connections on the rear section. Ensure that the locking pins are inserted fully. Hand tighten the rods by turning the turnbuckles until the 4 rods are taut, then secure the turnbuckles with the locking nut.

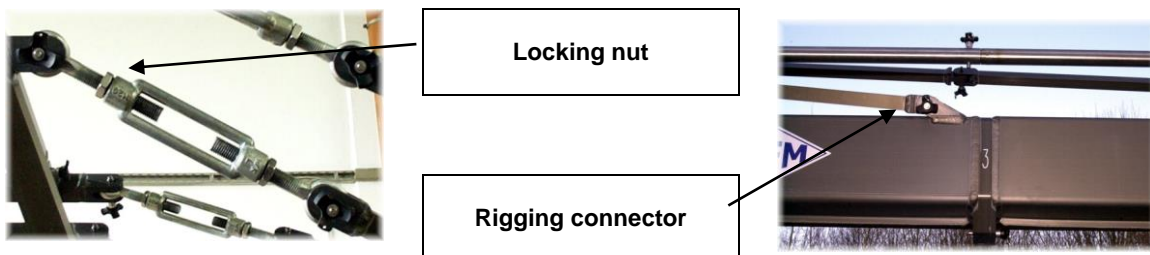

Note: All rigging support brackets are identical, all rigging rod connectors are identical, all standard rigging rods are identical.

In general, the length of the rigging system depends on the number of extension arms

assembled. For each extension arm, 1 rigging rod length consisting of 2 rods, is required. From Version 7 upwards, i.e. more than 3 extensions a double rigging system is required i.e. top and bottom.

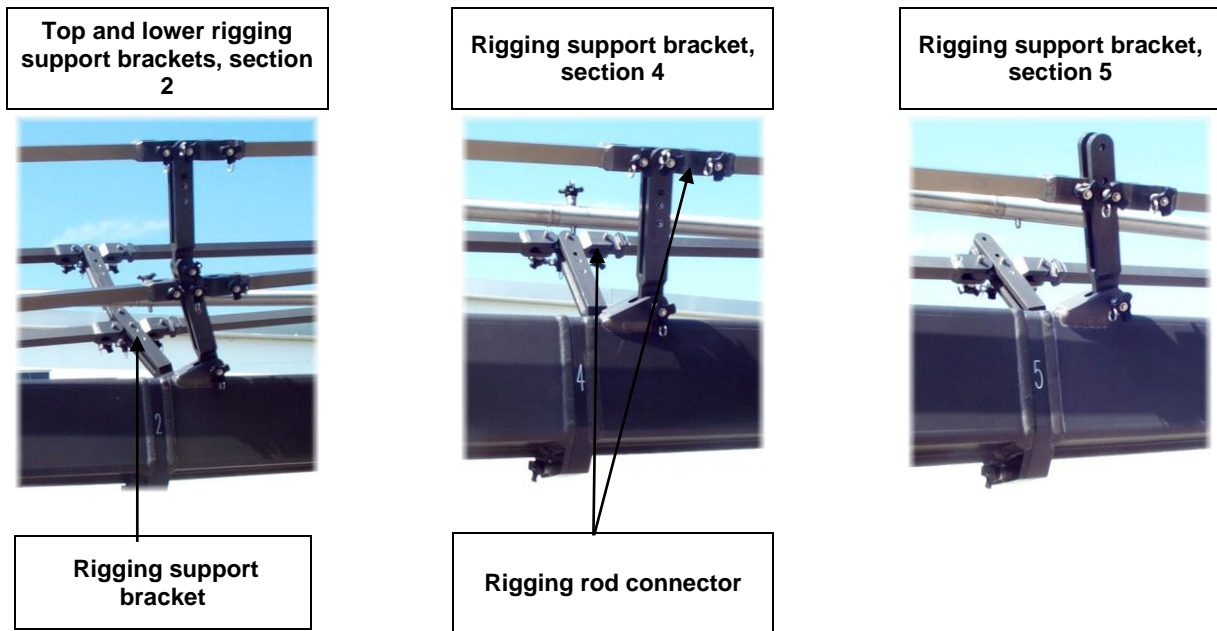

The top rigging system is assembled in the same manner as the lower but starts off at the top connection on the harness and finishes at the last extension.

The rigging system should be supported in certain positions with the Rigging Support Brackets which connect to various sections. The Rigging Support Brackets are connected to the Rigging Rod Connectors. Please refer to the individual versions as described on pages 7 to 43.

It is important that the rigging system when taut, should run in a straight line and the crane extensions should not bend or dip.

The second, fourth and fifth rigging rods are connected to the following rods via a rigging rod connector.

Parallelogram Supports

By adding extension sections in numerical order plus the respective parallelogram rods, 15 standard versions can be built. When sections number 2, 4 and 6 as well as the Remote section are used, support the respective parallelogram rods with the integrated parallelogram supports.

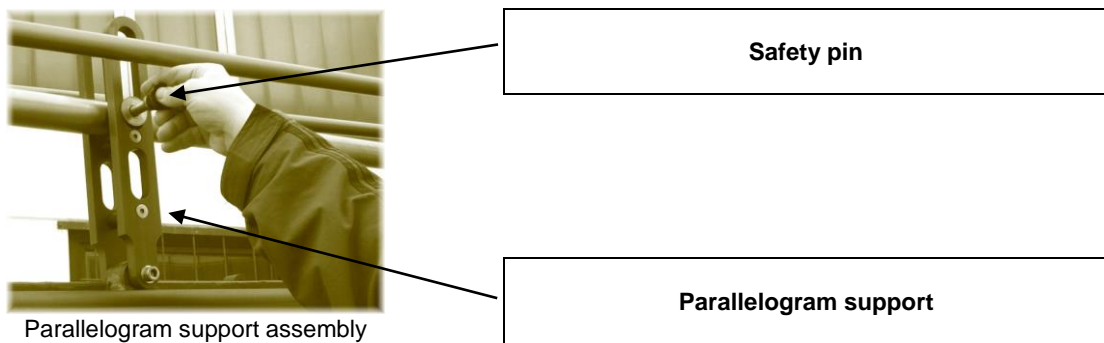

Version 3

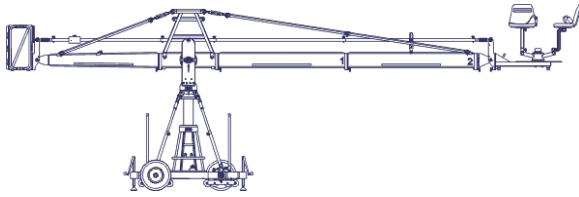

Front extension arms required	2 x 200 cm / 6' 6"
Rear extension arm required	1 x 192 cm / 6' 3"
Lift range	734 cm / 24'
Maximum Euro-adapter height	581 cm / 19'
Lift capacity (working load) 2 pers. + accessories	250 kg / 550 lbs
Counterweight required for max. load	554 kg / 1218 lbs
Counterweight required to balance empty arm	56 kg / 123 lbs
Crane weight (excluding dolly and weights)	730 kg / 1609 lbs
Dolly weight (unit weights see page 46)	244 kg / 536 lbs
Arm reach (pivot to camera head mount)	534 cm / 17' 6"
Length of rear end (pivot to outside of bucket)	278 cm / 9' 1"

Continue from § 12, page 6

13. Connect the 200cm / 6' 6" extension number 2 to extension number 1. Slip the connection flanges into each other and secure with the provided safety pin.

Note: Section 2 must be supported by a suitable support stand or rostrum.

Tip: To avoid the sections jamming or getting stuck make sure that the sections are joined parallel. Using a small amount of lubricant also helps. We suggest rubbing the joints with an oiled rag prior to assembly.

14. Connect a 200cm / 6' 6" parallelogram rod to the parallelogram connection on the middle section and secure it with the provided safety pin.

15. Connect another 200cm / 6' 6" parallelogram rod to the first parallelogram connection and secure it with the provided safety pin.

Note: Support the second parallelogram rod with the parallelogram support on section 2 and secure with the locking pin as shown on page 10.

16. Connect the angle adjuster to of the 200cm / 6' 6" extension number 2. Release the angle adjuster by removing the safety pins from the side of the angle adjuster. Secure the angle adjuster to extension number 2 with a removed safety pin.

Tip: The angle adjuster has two sidewise safety pins. These are either used for the angle adjusters transport position or to secure the connections between angle adjuster and extension as well as angle adjuster and platform.

17. Connect the last 200cm / 6' 6" parallelogram rod to the rod on the angle adjuster and secure it with the provided safety pin.

Tip: The angle adjuster has an integrated leveller. By turning it, the vertical plate on the angle adjuster can be set to a perfect right angle. Correct setting of the angle adjuster enhances the crane's balance.

The "Rigging Harness Assembly" is described on page 9. After reading and following the instructions, please proceed as follows.

18. Connect 2 turnbuckles to the top connection on the front side of the rigging harness. Ensure that the locking pins are inserted fully.
19. Connect 2 standard rigging rods to the turnbuckles on the front side of the rigging harness. Ensure that the locking pins are inserted fully.
20. Connect another 2 standard rigging rods to the first 2 standard rigging rods. Ensure that the locking pins are inserted fully.

21. Connect the last 2 standard rigging rods to the 2 rigging rod connectors on arm extension number 2. Ensure that the locking pins are inserted fully.
22. Hand tighten the rods by turning the turnbuckles until the rods are taut, then secure the turnbuckles with the locking nut as seen on page 9.
Attention: The rigging system when taut as well as the crane arm, should run in a straight line and should not bend or dip.
23. Connect the platform to the angle adjuster and secure with the removed safety pin from the side of the angle adjuster. Ensure that the platform is level.
Tip: The angle adjuster has an integrated leveller. By turning it, the vertical plate on the angle adjuster can be set to a perfect right angle. Correct setting of the angle adjuster enhances the crane's balance.
24. Remove the support stand or rostrum supporting the counterweight bucket section.
25. Then unlock the tilt friction.

Before operation, all locking pins, locking screws etc should be inspected to ensure that all assembly sections are securely fastened.

Read “Balancing the crane arm” on page 44.

Version 4

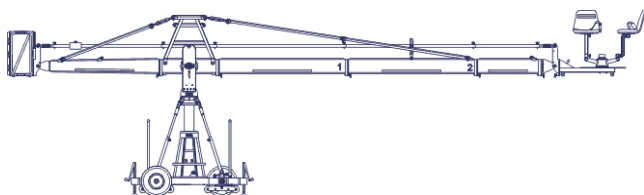

Front extension arms required	2 x 200 cm / 6' 6" + 1 x 100 cm / 3' 3"
Rear extension arm required	1 x 192 cm / 6' 3"
Lift range	890 cm / 29' 2"
Maximum Euro-adapter height	658 cm / 21' 7"
Lift capacity (working load) 2 pers. + accessories	250 kg / 550 lbs
Counterweight required for max. load	718 kg / 1579 lbs
Counterweight required to balance empty arm	112 kg / 246 lbs
Crane weight (excluding dolly and weights)	750 kg / 1653 lbs
Dolly weight (unit weights see page 46)	244 kg / 536 lbs
Arm reach (pivot to camera head mount)	631 cm / 20' 8"
Length of rear end (pivot to outside of bucket)	278 cm / 9' 1"

Continue from § 12, page 6

13. Connect the 200cm / 6' 6" extension number 2 to extension number 1. Slip the connection flanges into each other and secure with the provided safety pin.

Note: Section 2 must be supported by a suitable support stand or rostrum.

Tip: To avoid the sections jamming or getting stuck make sure that the sections are joined parallel. Using a small amount of lubricant also helps. We suggest rubbing the joints with an oiled rag prior to assembly.

14. Connect the 100cm / 3' 3" extension to extension number 2. Slip the connection flanges into each other and secure with the provided safety pin.

15. Connect a 200cm / 6' 6" parallelogram rod to the parallelogram connection on the middle section and secure it with the provided safety pin.

16. Connect another 200cm / 6' 6" parallelogram rod to the first parallelogram connection and secure it with the provided safety pin.

Note: Support the second parallelogram rod with the parallelogram support on section 2 and secure with the locking pin as shown on page 10.

17. Connect the 100cm / 3' 3" parallelogram rod to the last parallelogram connection and secure it with the provided safety pin.

18. Connect the angle adjuster to the end of the 100cm / 3' 3" extension. Release the angle adjuster by removing the safety pins from the side of the angle adjuster. Secure the angle adjuster to the 100cm / 3' 3" extension with a removed safety pin.

Tip: The angle adjuster has two sidewise safety pins. These are either used for the angle adjusters transport position or to secure the connections between angle adjuster and extension as well as angle adjuster and platform.

19. Connect the 100cm / 3' 3" parallelogram rod to the rod on the angle adjuster and secure it with the provided safety pin.

Tip: The angle adjuster has an integrated leveller. By turning it, the vertical plate on the angle adjuster can be set to a perfect right angle. Correct setting of the angle adjuster enhances the crane's balance.

The "Rigging Harness Assembly" is described on page 9. After reading and following the instructions, please proceed as follows.

20. Connect 2 turnbuckles to the top connection on the front side of the rigging harness. Ensure that the locking pins are inserted fully.

21. Connect 2 standard rigging rods to the turnbuckles on the front side of the rigging harness. Ensure that the locking pins are inserted fully.
22. Connect another 2 standard rigging rods to the first 2 standard rigging rods. Ensure that the locking pins are inserted fully.
23. Connect 2 rigging rods in turn to the connectors on extension number 2. Ensure that the locking pins are inserted fully.
24. Hand tighten the rods by turning the turnbuckles until the rods are taut, then secure the turnbuckles with the locking nut as seen on page 9.
Attention: The rigging system when taut as well as the crane arm, should run in a straight line and should not bend or dip.
25. Connect the platform to the angle adjuster and secure with the removed safety pin from the side of the angle adjuster. Ensure that the platform is level.
Tip: The angle adjuster has an integrated leveller. By turning it, the vertical plate on the angle adjuster can be set to a perfect right angle. Correct setting of the angle adjuster enhances the crane's balance.
26. Remove the support stand or rostrum supporting the counterweight bucket section.
27. Then unlock the tilt friction.

Before operation, all locking pins, locking screws etc should be inspected to ensure that all assembly sections are securely fastened.

Read “Balancing the crane arm” on page 44.

Version 5

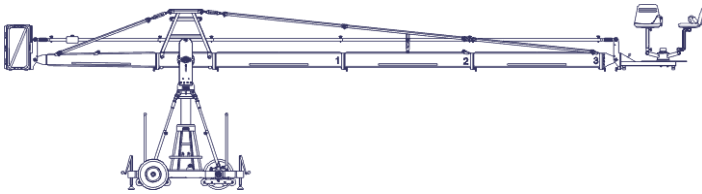

Front extension arms required	3 x 200 cm / 6' 6"
Rear extension arm required	1 x 192 cm / 6' 3"
Lift range	1049 cm / 34' 4"
Maximum Euro-adapter height	738 cm / 24' 2"
Lift capacity (working load) 2 pers. + accessories	250 kg / 550 lbs
Counterweight required for max. load	896 kg / 1971 lbs
Counterweight required to balance empty arm	182 kg / 400 lbs
Crane weight (excluding dolly and weights)	769 kg / 1695 lbs
Dolly weight (unit weights see page 46)	244 kg / 536 lbs
Arm reach (pivot to camera head mount)	731 cm / 23' 11"
Length of rear end (pivot to outside of bucket)	278 cm / 9' 1"

Continue from § 12, page 6.

13. Connect the 200cm / 6' 6" extension number 2 to extension number 1. Slip the connection flanges into each other and secure with the provided safety pin.

Note: Section 2 must be supported by a suitable support stand or rostrum.

Tip: To avoid the sections jamming or getting stuck make sure that the sections are joined parallel. Using a small amount of lubricant also helps. We suggest rubbing the joints with an oiled rag prior to assembly.

14. Connect the 200cm / 6' 6" extension number 3 to extension number 2. Slip the connection flanges into each other and secure with the provided safety pin.

Note: Move the support stand or rostrum to support section number 3.

15. Connect a 200cm / 6' 6" parallelogram rod to the parallelogram connection on the middle section and secure it with the provided safety pin.

16. In turn, connect 2 x 200cm / 6' 6" parallelogram rods to the first parallelogram connection and secure them with the provided safety pins.

17. Connect the angle adjuster to the end of the 200cm / 6' 6" extension number 3. Release the angle adjuster by removing the safety pins from the side of the angle adjuster. Secure the angle adjuster to extension number 3 with a removed safety pin.

Tip: The angle adjuster has two sidewise safety pins. These are either used for the angle adjusters transport position or to secure the connections between angle adjuster and extension as well as angle adjuster and platform.

18. Connect the last 200cm / 6' 6" parallelogram rod to the rod on the angle adjuster and secure it with the provided safety pin.

Tip: The angle adjuster has an integrated leveller. By turning it, the vertical plate on the angle adjuster can be set to a perfect right angle. Correct setting of the angle adjuster enhances the crane's balance.

The "Rigging Harness Assembly" is described on page 9. After reading and following the instructions, please proceed as follows.

19. Connect 2 turnbuckles to the top connection on the front side of the rigging harness. Ensure that the locking pins are inserted fully.
20. Connect 2 standard rigging rods to the turnbuckles on the front side of the rigging harness. Ensure that the locking pins are inserted fully.

21. Connect another 2 standard rigging rods to the first 2 standard rigging rods. Ensure that the locking pins are inserted fully.
22. Connect a Rigging Rod Connector to each of the second Rigging Rods ensuring that the locking pins are inserted fully.
23. Connect 2 standard rigging rods to the Rigging Rod Connectors and in turn to the rigging connectors on section 3. Ensure that the locking pins are inserted fully.
24. Hand tighten the rods by turning the turnbuckles until the rods are taut, then secure the turnbuckles with the locking nut as seen on page 9.
Attention: The rigging system when taut as well as the crane arm, should run in a straight line and should not bend or dip.
25. Connect the platform to the angle adjuster and secure with the removed safety pin from the side of the angle adjuster. Ensure that the platform is level.
Tip: The angle adjuster has an integrated leveller. By turning it, the vertical plate on the angle adjuster can be set to a perfect right angle. Correct setting of the angle adjuster enhances the crane's balance.
26. Remove the support stand or rostrum supporting the counterweight bucket section.
27. Then unlock the tilt friction.

Before operation, all locking pins, locking screws etc should be inspected to ensure that all assembly sections are securely fastened.

Read “Balancing the crane arm” on page 44.

Version 6

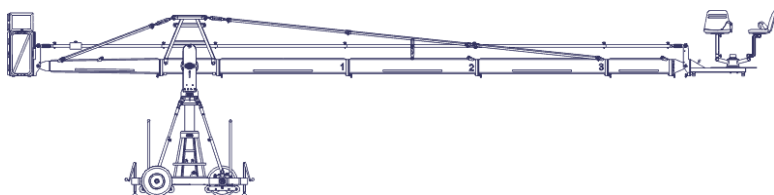

Front extension arms required	3 x 200 cm / 6' 6" + 1 x 100 cm / 3' 3"
Rear extension arm required	1 x 192 cm / 6' 3"
Lift range	1205 cm / 39' 6"
Maximum Euro-adapter height	816 cm / 26' 9"
Lift capacity (working load) 2 pers. + accessories	250 kg / 550 lbs
Counterweight required for max. load	1078 kg / 2371 lbs
Counterweight required to balance empty arm	266 kg / 585 lbs
Crane weight (excluding dolly and weights)	806 kg / 1777 lbs
Dolly weight (unit weights see page 46)	244 kg / 536 lbs
Arm reach (pivot to camera head mount)	829 cm / 27' 2"
Length of rear end (pivot to outside of bucket)	278 cm / 9' 1"

Continue from § 12, page 6

13. Connect the 200cm / 6' 6" extension number 2 to extension number 1. Slip the connection flanges into each other and secure with the provided safety pin.

Note: Section 2 must be supported by a suitable support stand or rostrum.

Tip: To avoid the sections jamming or getting stuck make sure that the sections are joined parallel. Using a small amount of lubricant also helps. We suggest rubbing the joints with an oiled rag prior to assembly.

14. Connect the 200cm / 6' 6" extension number 3 to extension number 2. Slip the connection flanges into each other and secure with the provided safety pin.

Note: Move the support stand or rostrum to support section 3.

15. Connect the 100cm / 3' 3" extension to extension number 3. Slip the connection flanges into each other and secure with the provided safety pin.

16. Connect a 200cm / 6' 6" parallelogram rod to the parallelogram connection on the middle section and secure it with the provided safety pin.

17. In turn, connect 2 x 200cm / 6' 6" parallelogram rods to the first parallelogram connection and secure them with the provided safety pins.

Note: Support the second parallelogram rod with the parallelogram support and secure with the locking pin.

18. Connect the 100cm / 3' 3" parallelogram rod to the last parallelogram connection and secure it with the provided safety pin.

19. Connect the angle adjuster to the end of the 100cm / 3' 3" extension. Release the angle adjuster by removing the safety pins from the side of the angle adjuster. Secure the angle adjuster to the 100cm / 3' 3" extension with a removed safety pin.

Tip: The angle adjuster has two sidewise safety pins. These are either used for the angle adjusters transport position or to secure the connections between angle adjuster and extension as well as angle adjuster and platform.

20. Connect the 100cm / 3' 3" parallelogram rod to the rod on the angle adjuster and secure it with the provided safety pin.

Tip: The angle adjuster has an integrated leveller. By turning it, the vertical plate on the angle adjuster can be set to a perfect right angle. Correct setting of the angle adjuster enhances the crane's balance.

The “Rigging Harness Assembly” is described on page 9. After reading and following the instructions, please proceed as follows.

21. Connect 2 turnbuckles to the top connection on the front side of the rigging harness. Ensure that the locking pins are inserted fully.
22. Connect 2 standard rigging rods to the turnbuckles on the front side of the rigging harness. Ensure that the locking pins are inserted fully.
23. Connect another 2 standard rigging rods to the first 2 standard rigging rods. Ensure that the locking pins are inserted fully.
24. Connect a Rigging Rod Connector to each of the second Rigging Rods ensuring that the locking pins are inserted fully .
25. Connect 2 standard rigging rods to the Rigging Rod Connectors and in turn to the rigging connectors on section 3. Ensure that the locking pins are inserted fully.
26. Hand tighten the rods by turning the turnbuckles until the rods are taut, then secure the turnbuckles with the locking nut as seen on page 9.
Attention: The rigging system when taut as well as the crane arm, should run in a straight line and should not bend or dip.
27. Connect the platform to the angle adjuster and secure with the removed safety pin from the side of the angle adjuster. Ensure that the platform is level.
Tip: The angle adjuster has an integrated leveller. By turning it, the vertical plate on the angle adjuster can be set to a perfect right angle. Correct setting of the angle adjuster enhances the crane’s balance.
28. Remove the support stand or rostrum supporting the counterweight bucket section.
29. Then unlock the tilt friction.

Before operation, all locking pins, locking screws etc should be inspected to ensure that all assembly sections are securely fastened.

Read “Balancing the crane arm” on page 44.

Version 7

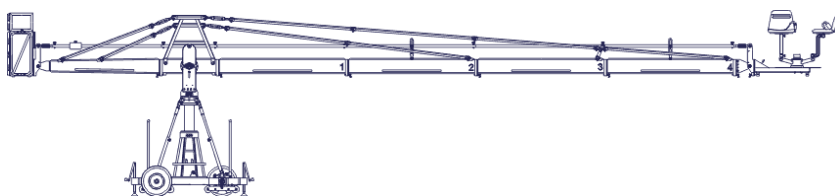

Front extension arms required	4 x 200 cm / 6' 6"
Rear extension arm required	1 x 192 cm / 6' 3"
Lift range	1364 cm / 44' 9"
Maximum Euro-adapter height	895 cm / 29' 4"
Lift capacity (working load) 2 pers. + accessories	250 kg / 550 lbs
Counterweight required for max. load	1274 kg / 2802 lbs
Counterweight required to balance empty arm	372 kg / 818lbs
Crane weight (excluding dolly and weights)	841 kg / 1854 lbs
Dolly weight (unit weights see page 46)	244 kg / 536 lbs
Arm reach (pivot to camera head mount)	929 cm / 30' 5"
Length of rear end (pivot to outside of bucket)	278 cm / 9' 1"

Continue from § 12, page 6

13. Connect the 200cm / 6' 6" extension number 2 to extension number 1. Slip the connection flanges into each other and secure with the provided safety pin.

Note: Section 2 must be supported by a suitable support stand or rostrum.

Tip: To avoid the sections jamming or getting stuck make sure that the sections are joined parallel. Using a small amount of lubricant also helps. We suggest rubbing the joints with an oiled rag prior to assembly.

The "Rigging Harness Assembly" is described on page 9. After reading and following the instructions, please proceed as follows.

14. Connect 2 turnbuckles to the bottom connection on the front side of the rigging harness. Ensure that the locking pins are inserted fully.
15. Connect 2 standard rigging rods to the turnbuckles on the front side of the rigging harness. Ensure that the locking pins are inserted fully.
16. Connect another 2 standard rigging rods to the first 2 standard rigging rods and in turn to the rigging connectors on section 2. Ensure that the locking pins are inserted fully.
17. Hand tighten the rods by turning the turnbuckles until the rods are taut, then secure the turnbuckles with the locking nut as seen on page 9.

Attention: The rigging system when taut as well as the crane arm, should run in a straight line and should not bend or dip.

18. Connect the 200cm / 6' 6" extension number 3 to extension number 2. Slip the connection flanges into each other and secure with the provided safety pin.

Note: Move the support stand or rostrum to support section number 3.

19. Connect the 200cm / 6' 6" extension number 4 to extension number 3. Slip the connection flanges into each other and secure with the provided safety pin.

20. Connect a 200cm / 6' 6" parallelogram rod to the parallelogram connection on the middle section and secure it with the provided safety pin.

21. In turn, connect 3 x 200cm / 6' 6" parallelogram rods to the first parallelogram connection and secure them with the provided safety pins.

Note: Support the second and fourth parallelogram rod with the parallelogram supports located on sections 2 and 4 and secure with the locking pin as shown on page 10.

22. Connect the angle adjuster to the end of the 200cm / 6' 6" extension number 4. Release the angle adjuster by removing the safety pins from the side of the angle adjuster. Secure the angle adjuster to extension number 4 with a removed safety pin.
Tip: The angle adjuster has two sidewise safety pins. These are either used for the angle adjusters transport position or to secure the connections between angle adjuster and extension as well as angle adjuster and platform.
23. Connect the last 200cm / 6' 6" parallelogram rod to the rod on the angle adjuster and secure it with the provided safety pin.
Tip: The angle adjuster has an integrated leveller. By turning it, the vertical plate on the angle adjuster can be set to a perfect right angle. Correct setting of the angle adjuster enhances the crane's balance.
24. Connect 2 turnbuckles to the top connection on the front side of the rigging harness. Ensure that the locking pins are inserted fully.
25. Connect 2 standard rigging rods to the turnbuckles on the front side of the rigging harness. Ensure that the locking pins are inserted fully.
26. Connect another 2 standard rigging rods to the first 2 standard rigging rods. Ensure that the locking pins are inserted fully.
27. Connect another 2 standard rigging rods to the second 2 standard rigging rods. Ensure that the locking pins are inserted fully.
28. Connect 2 Rigging Support Brackets to the Rigging Rod Connections on section 3. Ensure that the locking pins are inserted fully.
29. Connect a Rigging Rod Connector to each of the third Rigging Rods ensuring that the locking pins are inserted fully. Fit the Rigging Rod Connectors into the Rigging Support Brackets as shown on page 10.
30. Connect 2 standard rigging rods to the Rigging Rod Connectors and in turn to the rigging connectors on section 4. Ensure that the locking pins are inserted fully.
31. Hand tighten the rods by turning the turnbuckles until the rods are taut, then secure the turnbuckles with the locking nut as seen on page 9.
Attention: The rigging system when taut as well as the crane arm, should run in a straight line and should not bend or dip.
32. When the Rigging Rods are taut and running in a straight line, insert the locking pin connecting the Rigging Rod Connectors into the Rigging Support Brackets on section 3 as shown on page 10.
33. Connect the platform to the angle adjuster and secure with the removed safety pin from the side of the angle adjuster. Ensure that the platform is level.
Tip: The angle adjuster has an integrated leveller. By turning it, the vertical plate on the angle adjuster can be set to a perfect right angle. Correct setting of the angle adjuster enhances the crane's balance.
34. Remove the support stand or rostrum supporting the counterweight bucket section.
35. Then unlock the tilt friction.

Before operation, all locking pins, locking screws etc should be inspected to ensure that all assembly sections are securely fastened.

Read "Balancing the crane arm" on page 44.

Version 8

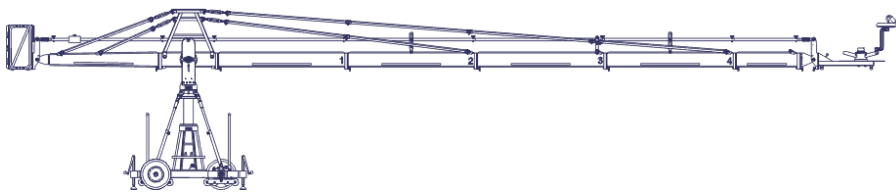

Front extension arms required	4 x 200 cm / 6' 6" + 1 x 100 cm / 3' 3"
Rear extension arm required	1 x 192 cm / 6' 3"
Lift range	1519 cm / 49' 10"
Maximum Euro-adaptor height	973 cm / 31' 11"
Lift capacity (working load) 1 pers. + accessories	140 kg / 308 lbs
Counterweight required for max. load	1022 kg / 2248 lbs
Counterweight required to balance empty arm	448 kg / 985 lbs
Crane weight (excluding dolly and weights)	838 kg / 1847 lbs
Dolly weight (unit weights see page 46)	244 kg / 536 lbs
Arm reach (pivot to camera head mount)	1027 cm / 33' 8"
Length of rear end (pivot to outside of bucket)	278 cm / 9' 1"

Continue from § 12, page 6

13. Connect the 200cm / 6' 6" extension number 2 to extension number 1. Slip the connection flanges into each other and secure with the provided safety pin.

Note: Section 2 must be supported by a suitable support stand or rostrum.

Tip: To avoid the sections jamming or getting stuck make sure that the sections are joined parallel. Using a small amount of lubricant also helps. We suggest rubbing the joints with an oiled rag prior to assembly.

The "Rigging Harness Assembly" is described on page 9. After reading and following the instructions, please proceed as follows.

14. Connect 2 turnbuckles to the bottom connection on the front side of the rigging harness. Ensure that the locking pins are inserted fully.
15. Connect 2 standard rigging rods to the turnbuckles on the front side of the rigging harness. Ensure that the locking pins are inserted fully.
16. Connect another 2 standard rigging rods to the first 2 standard rigging rods and in turn to the rigging connectors on section 2. Ensure that the locking pins are inserted fully.
17. Hand tighten the rods by turning the turnbuckles until the rods are taut, then secure the turnbuckles with the locking nut as seen on page 9.
- Attention:** The rigging system when taut as well as the crane arm, should run in a straight line and should not bend or dip.
18. Connect the 200cm / 6' 6" extension number 3 to extension number 2. Slip the connection flanges into each other and secure with the provided safety pin.
- Note:** Move the support stand or rostrum to support section 3.
19. Connect the 200cm / 6' 6" extension number 4 to extension number 3. Slip the connection flanges into each other and secure with the provided safety pin.
20. Connect the 100cm / 3' 3" extension to extension number 4. Slip the connection flanges into each other and secure with the provided safety pin.
- Note:** Section 4 must be supported by a suitable support stand or rostrum.
21. Connect a 200cm / 6' 6" parallelogram rod to the parallelogram connection on the middle section and secure it with the provided safety pin.
22. In turn, connect 3 x 200cm / 6' 6" parallelogram rods to the first parallelogram connection and secure them with the provided safety pins.

Note: Support the second and fourth parallelogram rod with the parallelogram supports located on sections 2 and 4 and secure with the locking pin as shown on page 10.

23. Connect the 100cm / 3' 3" parallelogram rod to the last parallelogram connection and secure it with the provided safety pin.

24. Connect the angle adjuster to the end of the 100cm / 3' 3" extension. Release the angle adjuster by removing the safety pins from the side of the angle adjuster. Secure the angle adjuster to the 100cm / 3' 3" extension with a removed safety pin.

Tip: The angle adjuster has two sidewise safety pins. These are either used for the angle adjusters transport position or to secure the connections between angle adjuster and extension as well as angle adjuster and platform.

25. Connect the 100cm / 3' 3" parallelogram rod to the rod on the angle adjuster and secure it with the provided safety pin.

Tip: The angle adjuster has an integrated leveller. By turning it, the vertical plate on the angle adjuster can be set to a perfect right angle. Correct setting of the angle adjuster enhances the crane's balance.

26. Connect 2 turnbuckles to the top connection on the front side of the rigging harness. Ensure that the locking pins are inserted fully.

27. Connect 2 standard rigging rods to the turnbuckles on the front side of the rigging harness. Ensure that the locking pins are inserted fully.

28. Connect another 2 standard rigging rods to the first 2 standard rigging rods. Ensure that the locking pins are inserted fully.

29. Connect another 2 standard rigging rods to the second 2 standard rigging rods. Ensure that the locking pins are inserted fully.

30. Connect 2 Rigging Support Brackets to the Rigging Rod Connections on section 3. Ensure that the locking pins are inserted fully.

31. Connect a Rigging Rod Connector to each of the third Rigging Rods ensuring that the locking pins are inserted fully. Fit the Rigging Rod Connectors into the Rigging Support Brackets as shown on page 10.

32. Connect 2 standard rigging rods to the Rigging Rod Connectors and in turn to the rigging connectors on section 4. Ensure that the locking pins are inserted fully.

33. Hand tighten the rods by turning the turnbuckles until the rods are taut, then secure the turnbuckles with the locking nut as seen on page 9.

Attention: The rigging system when taut as well as the crane arm, should run in a straight line and should not bend or dip.

34. When the Rigging Rods are taut and running in a straight line, insert the locking pin connecting the Rigging Rod Connectors into the Rigging Support Brackets on section 3 as shown on page 10.

35. Connect the platform to the angle adjuster and secure with the removed safety pin from the side of the angle adjuster. Ensure that the platform is level.

Tip: The angle adjuster has an integrated leveller. By turning it, the vertical plate on the angle adjuster can be set to a perfect right angle. Correct setting of the angle adjuster enhances the crane's balance.

36. Remove the support stand or rostrum supporting the counterweight bucket section.

37. Then unlock the tilt friction.

Before operation, all locking pins, locking screws etc should be inspected to ensure that all assembly sections are securely fastened.

Read "Balancing the crane arm" on page 44.

Version 9

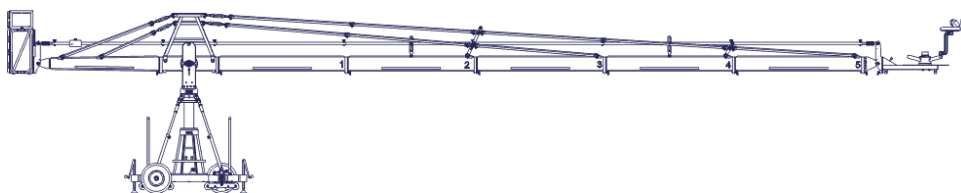

Front extension arms required	5 x 200 cm / 6' 6"
Rear extension arm required	1 x 192 cm / 6' 3"
Lift range	1678 cm / 55'
Maximum Euro-adapter height	1053 cm / 34' 6"
Lift capacity (working load) 1 pers. + accessories	140 kg / 308 lbs
Counterweight required for max. load	1166 kg / 2565 lbs
Counterweight required to balance empty arm	554 kg / 1218 lbs
Crane weight (excluding dolly and weights)	876 kg / 1931 lbs
Dolly weight (unit weights see page 46)	244 kg / 536 lbs
Arm reach (pivot to camera head mount)	1127 cm / 36' 11"
Length of rear end (pivot to outside of bucket)	278 cm / 9' 1"

Continue from § 12, page 6

13. Connect the 200cm / 6' 6" extension number 2 to extension number 1. Slip the connection flanges into each other and secure with the provided safety pin.

Note: Section 2 must be supported by a suitable support stand or rostrum.

Tip: To avoid the sections jamming or getting stuck make sure that the sections are joined parallel. Using a small amount of lubricant also helps. We suggest rubbing the joints with an oiled rag prior to assembly.

14. Connect the 200cm / 6' 6" extension number 3 to extension number 2. Slip the connection flanges into each other and secure with the provided safety pin.

Note: Move the support stand or rostrum to support section number 3.

The "Rigging Harness Assembly" is described on page 9. After reading and following the instructions, please proceed as follows.

15. Connect 2 turnbuckles to the bottom connection on the front side of the rigging harness. Ensure that the locking pins are inserted fully.
16. Connect 2 standard rigging rods to the turnbuckles on the front side of the rigging harness. Ensure that the locking pins are inserted fully.
17. Connect another 2 standard rigging rods to the first 2 standard rigging rods. Ensure that the locking pins are inserted fully.
18. Connect 2 Rigging Support Brackets to the Rigging Rod Connections on section 2. Ensure that the locking pins are inserted fully.
19. Connect a Rigging Rod Connector to each of the second Rigging Rods ensuring that the locking pins are inserted fully. Fit the Rigging Rod Connectors into the Rigging Support Brackets as shown on page 10.
20. Connect 2 standard rigging rods to the Rigging Rod Connectors and in turn to the rigging connectors on section 3. Ensure that the locking pins are inserted fully.
21. Hand tighten the rods by turning the turnbuckles until the rods are taut, then secure the turnbuckles with the locking nut as seen on page 9.

Attention: The rigging system when taut as well as the crane arm, should run in a straight line and should not bend or dip.

22. When the Rigging Rods are taut and running in a straight line, insert the locking pin connecting the Rigging Rod Connectors into the Rigging Support Brackets on section 3 as shown on page 10.

23. Connect the 200cm / 6' 6" extension number 4 to extension number 3. Slip the connection flanges into each other and secure with the provided safety pin.
24. Connect the 200cm / 6' 6" extension number 5 to extension number 4. Slip the connection flanges into each other and secure with the provided safety pin.
Note: Section 5 must be supported by a suitable support stand or rostrum.
25. Connect a 200cm / 6' 6" parallelogram rod to the parallelogram connection on the middle section and secure it with the provided safety pin.
26. In turn, connect 4 x 200cm / 6' 6" parallelogram rods to the first parallelogram connection and secure them with the provided safety pins.
Note: Support the second and fourth parallelogram rod with the parallelogram support located on sections 2 and 4 and secure with the locking pin as shown on page 10.
27. Connect the angle adjuster to the end of the 200cm / 6' 6" extension number 5. Release the angle adjuster by removing the safety pins from the side of the angle adjuster. Secure the angle adjuster to extension number 5 with a removed safety pin.
Tip: The angle adjuster has two sidewise safety pins. These are either used for the angle adjusters transport position or to secure the connections between angle adjuster and extension as well as angle adjuster and platform.
28. Connect the last 200cm / 6' 6" parallelogram rod to the rod on the angle adjuster and secure it with the provided safety pin.
Tip: The angle adjuster has an integrated leveller. By turning it, the vertical plate on the angle adjuster can be set to a perfect right angle. Correct setting of the angle adjuster enhances the crane's balance.
29. Connect 2 turnbuckles to the top connection on the front side of the rigging harness. Ensure that the locking pins are inserted fully.
30. Connect 2 standard rigging rods to the turnbuckles on the front side of the rigging harness. Ensure that the locking pins are inserted fully.
31. Connect another 2 standard rigging rods to the first 2 standard rigging rods. Ensure that the locking pins are inserted fully.
32. Connect 2 Rigging Support Brackets to the Rigging Support Brackets on section 2. Ensure that the locking pins are inserted fully.
33. Connect a Rigging Rod Connector to each of the second Rigging Rods ensuring that the locking pins are inserted fully. Fit the Rigging Rod Connectors into the Rigging Support Brackets as shown on page 10.
34. Connect another 2 standard rigging rods to the Rigging Rod Connectors on the second 2 standard rigging rods. Ensure that the locking pins are inserted fully.
35. Connect another 2 standard rigging rods to the third 2 standard rigging rods. Ensure that the locking pins are inserted fully.
36. Connect 2 Rigging Support Brackets to the Rigging Rod Connections on section 4. Ensure that the locking pins are inserted fully.
37. Connect a Rigging Rod Connector to each of the fourth Rigging Rods ensuring that the locking pins are inserted fully. Fit the Rigging Rod Connectors into the Rigging Support Brackets on section 4 as shown on page 10.
38. Connect 2 standard rigging rods to the Rigging Rod Connectors and in turn to the rigging connectors on section 5. Ensure that the locking pins are inserted fully.
39. Hand tighten the rods by turning the turnbuckles until the rods are taut, then secure the turnbuckles with the locking nut as seen on page 9.
Attention: The rigging system when taut as well as the crane arm, should run in a straight line and should not bend or dip.
40. When the Rigging Rods are taut and running in a straight line, insert the locking pin connecting the Rigging Rod Connectors into the Rigging Support Brackets on section 2 and section 4 as shown on page 10.

41. Connect the platform to the angle adjuster and secure with the removed safety pin from the side of the angle adjuster. Ensure that the platform is level.
Tip: The angle adjuster has an integrated leveller. By turning it, the vertical plate on the angle adjuster can be set to a perfect right angle. Correct setting of the angle adjuster enhances the crane's balance.
42. Remove the support stand or rostrum supporting the counterweight bucket section.
43. Then unlock the friction.

Before operation, all locking pins, locking screws etc should be inspected to ensure that all assembly sections are securely fastened.

Read “Balancing the crane arm” on page 44.

Version 10

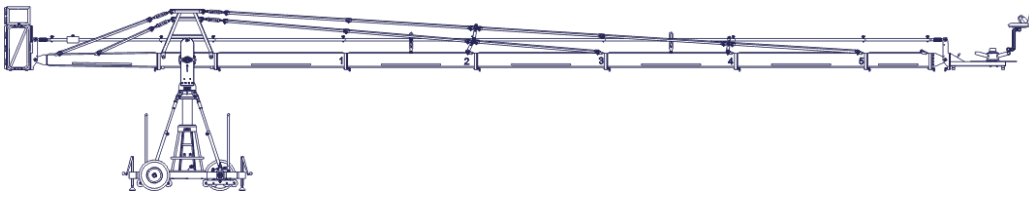

Front extension arms required	5 x 200 cm / 6' 6" + 1 x 100 cm / 3' 3"
Rear extension arm required	1 x 192 cm / 6' 3"
Lift range	1834 cm / 60' 2"
Maximum Euro-adapter height	1130 cm / 37'
Lift capacity (working load) 1 pers + accessories	130 kg / 286 lbs
Counterweight required for max. load	1330 kg / 2926 lbs
Counterweight required to balance empty arm	658 kg / 1447 lbs
Crane weight (excluding dolly and weights)	896 kg / 1975 lbs
Dolly weight (unit weights see page 46)	244 kg / 536 lbs
Arm reach (pivot to camera head mount)	1225 cm / 40' 2"
Length of rear end (pivot to outside of bucket)	278 cm / 9' 1"

Continue from § 12, page 6

13. Connect the 200cm / 6' 6" extension number 2 to extension number 1. Slip the connection flanges into each other and secure with the provided safety pin.
Note: Section 2 must be supported by a suitable support stand or rostrum.
Tip: To avoid the sections jamming or getting stuck make sure that the sections are joined parallel. Using a small amount of lubricant also helps. We suggest rubbing the joints with an oiled rag prior to assembly.
14. Connect the 200cm / 6' 6" extension number 3 to extension number 2. Slip the connection flanges into each other and secure with the provided safety pin.
Note: Move the support stand or rostrum to support section number 3.

The "Rigging Harness Assembly" is described on page 9. After reading and following the instructions, please proceed as follows.

15. Connect 2 turnbuckles to the bottom connection on the front side of the rigging harness. Ensure that the locking pins are inserted fully.
16. Connect 2 standard rigging rods to the turnbuckles on the front side of the rigging harness. Ensure that the locking pins are inserted fully.
17. Connect another 2 standard rigging rods to the first 2 standard rigging rods. Ensure that the locking pins are inserted fully.
18. Connect 2 Rigging Support Brackets to the Rigging Rod Connections on section 2. Ensure that the locking pins are inserted fully.
19. Connect a Rigging Rod Connector to each of the second Rigging Rods ensuring that the locking pins are inserted fully. Fit the Rigging Rod Connectors into the Rigging Support Brackets as shown on page 10.
20. Connect 2 standard rigging rods to the Rigging Rod Connectors and in turn to the rigging connectors on section 3. Ensure that the locking pins are inserted fully.
21. Hand tighten the rods by turning the turnbuckles until the rods are taut, then secure the turnbuckles with the locking nut as seen on page 9.
Attention: The rigging system when taut as well as the crane arm, should run in a straight line and should not bend or dip.
22. When the Rigging Rods are taut and running in a straight line, insert the locking pin connecting the Rigging Rod Connectors into the Rigging Support Brackets on section 3 as shown on page 10.

23. Connect the 200cm / 6' 6" extension number 4 to extension number 3. Slip the connection flanges into each other and secure with the provided safety pin.
24. Connect the 200cm / 6' 6" extension number 5 to extension number 4. Slip the connection flanges into each other and secure with the provided safety pin.
Note: Section 5 must be supported by a suitable support stand or rostrum.
25. Connect the 100cm / 3' 3" extension to extension number 5. Slip the connection flanges into each other and secure with the provided safety pin.
26. Connect a 200cm / 6' 6" parallelogram rod to the parallelogram connection on the middle section and secure it with the provided safety pin.
27. In turn, connect 4 x 200cm / 6' 6" parallelogram rods to the first parallelogram connection and secure them with the provided safety pins.
Note: Support the second and fourth parallelogram rod with the parallelogram support located on sections 2 and 4 and secure with the locking pin as shown on page 10.
28. Connect the 100cm / 3' 3" parallelogram rod to the last parallelogram connection and secure it with the provided safety pin.
29. Connect the angle adjuster to the end of the 100cm / 3' 3" extension. Release the angle adjuster by removing the safety pins from the side of the angle adjuster. Secure the angle adjuster to the 100cm / 3' 3" extension with a removed safety pin.
Tip: The angle adjuster has two sidewise safety pins. These are either used for the angle adjusters transport position or to secure the connections between angle adjuster and extension as well as angle adjuster and platform.
30. Connect the 100cm / 3' 3" parallelogram rod to the rod on the angle adjuster and secure it with the provided safety pin.
Tip: The angle adjuster has an integrated leveller. By turning it, the vertical plate on the angle adjuster can be set to a perfect right angle. Correct setting of the angle adjuster enhances the crane's balance.
31. Connect 2 turnbuckles to the top connection on the front side of the rigging harness. Ensure that the locking pins are inserted fully.
32. Connect 2 standard rigging rods to the turnbuckles on the front side of the rigging harness. Ensure that the locking pins are inserted fully.
33. Connect another 2 standard rigging rods to the first 2 standard rigging rods. Ensure that the locking pins are inserted fully.
34. Connect 2 Rigging Support Brackets to the Rigging Support Brackets on section 2. Ensure that the locking pins are inserted fully.
35. Connect a Rigging Rod Connector to each of the second Rigging Rods ensuring that the locking pins are inserted fully. Fit the Rigging Rod Connectors into the Rigging Support Brackets as shown on page 10.
36. Connect another 2 standard rigging rods to the Rigging Rod Connectors on the second 2 standard rigging rods. Ensure that the locking pins are inserted fully.
37. Connect another 2 standard rigging rods to the third 2 standard rigging rods. Ensure that the locking pins are inserted fully.
38. Connect 2 Rigging Support Brackets to the Rigging Rod Connections on section 4. Ensure that the locking pins are inserted fully.
39. Connect a Rigging Rod Connector to each of the fourth Rigging Rods ensuring that the locking pins are inserted fully. Fit the Rigging Rod Connectors into the Rigging Support Brackets on section 4 as shown on page 10.
40. Connect 2 standard rigging rods to the Rigging Rod Connectors and in turn to the rigging connectors on section 5. Ensure that the locking pins are inserted fully.
41. Hand tighten the rods by turning the turnbuckles until the rods are taut, then secure the turnbuckles with the locking nut as seen on page 9.
Attention: The rigging system when taut as well as the crane arm, should run in a

straight line and should not bend or dip.

42. When the Rigging Rods are taut and running in a straight line, insert the locking pin connecting the Rigging Rod Connectors into the Rigging Support Brackets on section 2 and 4 as shown on page 10.
43. Connect the platform to the angle adjuster and secure with the removed safety pin from the side of the angle adjuster. Ensure that the platform is level.
Tip: The angle adjuster has an integrated leveller. By turning it, the vertical plate on the angle adjuster can be set to a perfect right angle. Correct setting of the angle adjuster enhances the crane's balance.
44. Remove the support stand or rostrum supporting the counterweight bucket section.
45. Then unlock the tilt friction.

Before operation, all locking pins, locking screws etc should be inspected to ensure that all assembly sections are securely fastened.

Read "Balancing the crane arm" on page 44.

Version 11

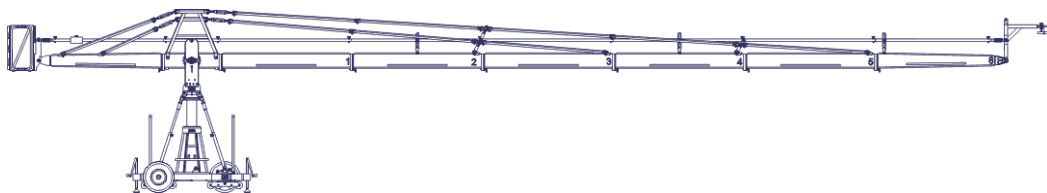

Front extension arms required	6 x 200 cm / 6' 6"
Rear extension arm required	1 x 192 cm / 6' 3"
Lift range	1954 cm / 64' 1"
Maximum Euro-adapter height	1217 cm / 39' 11"
Lift capacity (working load) camera + accessories	85 kg / 187 lbs
Counterweight required for max. load	974 kg / 2142 lbs
Counterweight required to balance empty arm	518 kg / 1139 lbs
Crane weight (excluding dolly and weights)	846 kg / 1865 lbs
Dolly weight (unit weights see page 46)	244 kg / 536 lbs
Arm reach (pivot to camera head mount)	1286 cm / 42' 2"
Length of rear end (pivot to outside of bucket)	278 cm / 9' 1"

Continue from § 12, page 6

13. Connect the 200cm / 6' 6" extension number 2 to extension number 1. Slip the connection flanges into each other and secure with the provided safety pin.

Note: Section 2 must be supported by a suitable support stand or rostrum.

Tip: To avoid the sections jamming or getting stuck make sure that the sections are joined parallel. Using a small amount of lubricant also helps. We suggest rubbing the joints with an oiled rag prior to assembly.

14. Connect the 200cm / 6' 6" extension number 3 to extension number 2. Slip the connection flanges into each other and secure with the provided safety pin.

Note: Move the support stand or rostrum to support section number 3.

The "Rigging Harness Assembly" is described on page 9. After reading and following the instructions, please proceed as follows.

15. Connect 2 turnbuckles to the bottom connection on the front side of the rigging harness. Ensure that the locking pins are inserted fully.
16. Connect 2 standard rigging rods to the turnbuckles on the front side of the rigging harness. Ensure that the locking pins are inserted fully.
17. Connect 2 standard rigging rods to the first 2 rigging rods. Ensure that the locking pins are inserted fully.
18. Connect 2 Rigging Support Brackets to the Rigging Rod Connections on section 2. Ensure that the locking pins are inserted fully.
19. Connect a Rigging Rod Connector to each of the second Rigging Rods ensuring that the locking pins are inserted fully. Fit the Rigging Rod Connectors into the Rigging Support Brackets as shown on page 10.
20. Connect 2 standard rigging rods to the Rigging Rod Connectors and in turn to the to the rigging connectors on section 3. Ensure that the locking pins are inserted fully.
21. Hand tighten the rods by turning the turnbuckles until the rods are taut, then secure the turnbuckles with the locking nut as seen on page 9.

Attention: The rigging system when taut as well as the crane arm, should run in a straight line and should not bend or dip.

22. When the Rigging Rods are taut and running in a straight line, insert the locking pin connecting the Rigging Rod Connectors into the Rigging Support Brackets on section 2 as shown on page 10.

23. Connect the 200cm / 6' 6" extension number 4 to extension number 3. Slip the connection flanges into each other and secure with the provided safety pin.
24. Connect the 200cm / 6' 6" extension number 5 to extension number 4. Slip the connection flanges into each other and secure with the provided safety pin.
Note: Section 5 must be supported by a suitable support stand or rostrum.
25. Connect the Remote Extension to 200cm / 6' 6" extension number 5. Slip the connection flanges into each other and secure with the provided safety pin.
26. Connect a 200cm / 6' 6" parallelogram rod to the parallelogram connection on the middle section and secure it with the provided safety pin.
27. In turn, connect 4 x 200cm / 6' 6" parallelogram rods to the first parallelogram connection and secure them with the provided safety pin.
Note: Support the second and fourth parallelogram rod with the parallelogram support located on sections 2 and 4 and secure with the locking pin as shown on page 10.
28. Connect the Remote Extension parallelogram rod to the last parallelogram connection and secure it with the provided safety pin.
29. Support the Remote Extension parallelogram rod with the parallelogram support located on the Remote Extension and secure with the locking pin as shown on page 10.
30. Connect the Remote Bracket as described on page 43.
Tip: The Remote Bracket has an integrated leveller. By turning it, the Remote Bracket can be set to a perfect right angle. Correct setting of the angle adjuster enhances the crane's balance.
31. Connect 2 turnbuckles to the top connection on the front side of the rigging harness. Ensure that the locking pins are inserted fully.
32. Connect 2 standard rigging rods to the turnbuckles on the front side of the rigging harness. Ensure that the locking pins are inserted fully.
33. Connect another 2 standard rigging rods to the first 2 standard rigging rods. Ensure that the locking pins are inserted fully.
34. Connect 2 Rigging Support Brackets to the Rigging Support Brackets on section 2. Ensure that the locking pins are inserted fully.
35. Connect a Rigging Rod Connector to each of the second Rigging Rods ensuring that the locking pins are inserted fully. Fit the Rigging Rod Connectors into the Rigging Support Brackets as shown on page 10.
36. Connect another 2 standard rigging rods to the Rigging Rod Connectors on the second 2 standard rigging rods. Ensure that the locking pins are inserted fully.
37. Connect another 2 standard rigging rods to the third 2 standard rigging rods. Ensure that the locking pins are inserted fully.
38. Connect 2 Rigging Support Brackets to the Rigging Rod Connections on section 4. Ensure that the locking pins are inserted fully.
39. Connect a Rigging Rod Connector to each of the fourth Rigging Rods ensuring that the locking pins are inserted fully. Fit the Rigging Rod Connectors into the Rigging Support Brackets on section 4 as shown on page 10.
40. Connect 2 standard rigging rods to the Rigging Rod Connectors and in turn to the rigging connectors on section 5. Ensure that the locking pins are inserted fully.
41. Hand tighten the rods by turning the turnbuckles until the rods are taut, then secure the turnbuckles with the locking nut as seen on page 9.
Attention: The rigging system when taut as well as the crane arm, should run in a straight line and should not bend or dip.
42. When the Rigging Rods are taut and running in a straight line, insert the locking pin connecting the Rigging Rod Connectors into the Rigging Support Brackets on section 2 and section 4 as shown on page 10.

43. Remove the support stand or rostrum supporting the counterweight bucket section.
44. Then unlock the tilt friction.

Before operation, all locking pins, locking screws etc should be inspected to ensure that all assembly sections are securely fastened.

Read “Balancing the crane arm” on page 44.

Version 12

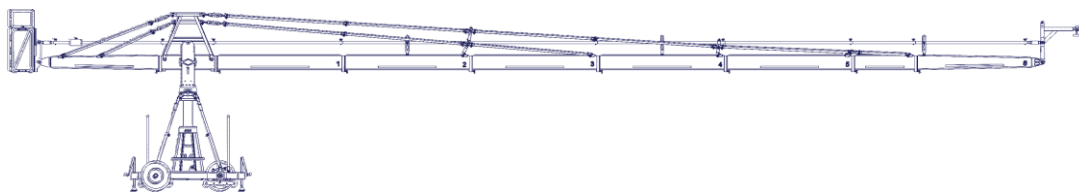

Front extension arms required	6 x 200 cm / 6' 6" + 1 x 100 cm / 3' 3"
Rear extension arm required	1 x 192 cm / 6' 3"
Lift range	2110 cm / 69' 2"
Maximum Euro-adapter height	1294 cm / 42' 5"
Lift capacity (working load) camera + accessories	85 kg / 187 lbs
Counterweight required for max. load	1134 kg / 2494 lbs
Counterweight required to balance empty arm	700 kg / 1540 lbs
Crane weight (excluding dolly and weights)	882 kg / 1944 lbs
Dolly weight (unit weights see page 46)	244 kg / 536 lbs
Arm reach (pivot to camera head mount)	1383 cm / 45' 4"
Length of rear end (pivot to outside of bucket)	278 cm / 9' 1"

Continue from § 12, page 6

13. Connect the 200cm / 6' 6" extension number 2 to extension number 1. Slip the connection flanges into each other and secure with the provided safety pin.

Note: Section 2 must be supported by a suitable support stand or rostrum.

Tip: To avoid the sections jamming or getting stuck make sure that the sections are joined parallel. Using a small amount of lubricant also helps. We suggest rubbing the joints with an oiled rag prior to assembly.

14. Connect the 200cm / 6' 6" extension number 3 to extension number 2. Slip the connection flanges into each other and secure with the provided safety pin.

Note: Move the support stand or rostrum to support section number 3.

The "Rigging Harness Assembly" is described on page 9. After reading and following the instructions, please proceed as follows.

15. Connect 2 turnbuckles to the bottom connection on the front side of the rigging harness. Ensure that the locking pins are inserted fully.

16. Connect 2 standard rigging rods to the turnbuckles on the front side of the rigging harness. Ensure that the locking pins are inserted fully.

17. Connect another 2 standard rigging rods to the first 2 rigging rods. Ensure that the locking pins are inserted fully.

18. Connect 2 Rigging Support Brackets to the Rigging Rod Connections on section 2. Ensure that the locking pins are inserted fully.

19. Connect a Rigging Rod Connector to each of the second Rigging Rods ensuring that the locking pins are inserted fully. Fit the Rigging Rod Connectors into the Rigging Support Brackets as shown on page 10.

20. Connect 2 standard rigging rods to the Rigging Rod Connectors and in turn to the rigging connectors on section 3. Ensure that the locking pins are inserted fully.

21. Hand tighten the rods by turning the turnbuckles until the rods are taut, then secure the turnbuckles with the locking nut as seen on page 9.

Attention: The rigging system when taut as well as the crane arm, should run in a straight line and should not bend or dip.

22. When the Rigging Rods are taut and running in a straight line, insert the locking pin connecting the Rigging Rod Connectors into the Rigging Support Brackets on section 3 as shown on page 10.

23. Connect the 200cm / 6' 6" extension number 4 to extension number 3. Slip the connection flanges into each other and secure with the provided safety pin.

24. Connect the 200cm / 6' 6" extension number 5 to extension number 4. Slip the connection flanges into each other and secure with the provided safety pin.
Note: Section 5 must be supported by a suitable support stand or rostrum.
25. Connect the 100cm / 3' 3" extension to extension number 5. Slip the connection flanges into each other and secure with the provided safety pin.
26. Connect the Remote Extension to 100cm / 3' 3" extension. Slip the connection flanges into each other and secure with the provided safety pin.
27. Connect a 200cm / 6' 6" parallelogram rod to the parallelogram connection on the middle section and secure it with the provided safety pin.
28. In turn, connect 4 x 200cm / 6' 6" parallelogram rods to the first parallelogram connection and secure them with the provided safety pins.
Note: Support the second and fourth parallelogram rod with the parallelogram support located on sections 2 and 4 and secure with the locking pin as shown on page 10.
29. Connect the 100cm / 3' 3" parallelogram rod to the last parallelogram connection and secure it with the provided safety pin.
30. Connect the Remote Extension parallelogram rod to the 100cm / 3' 3" parallelogram connection and secure it with the provided safety pin.
31. Support the Remote Extension parallelogram rod with the parallelogram support located on the Remote Extension and secure with the locking pin as shown on page 10.
32. Connect the Remote Bracket as described on page 43.
Tip: The Remote Bracket has an integrated leveller. By turning it, the Remote Bracket can be set to a perfect right angle. Correct setting of the angle adjuster enhances the crane's balance.
33. Connect 2 turnbuckles to the top connection on the front side of the rigging harness. Ensure that the locking pins are inserted fully.
34. Connect 2 standard rigging rods to the turnbuckles on the front side of the rigging harness. Ensure that the locking pins are inserted fully.
35. Connect another 2 standard rigging rods to the first 2 standard rigging rods. Ensure that the locking pins are inserted fully.
36. Connect 2 Rigging Support Brackets to the Rigging Support Brackets on section 2. Ensure that the locking pins are inserted fully.
37. Connect a Rigging Rod Connector to each of the second Rigging Rods ensuring that the locking pins are inserted fully. Fit the Rigging Rod Connectors into the Rigging Support Brackets as shown on page 10.
38. Connect another 2 standard rigging rods to the Rigging Rod Connectors on the second 2 standard rigging rods. Ensure that the locking pins are inserted fully.
39. Connect another 2 standard rigging rods to the third 2 standard rigging rods. Ensure that the locking pins are inserted fully.
40. Connect 2 Rigging Support Brackets to the Rigging Rod Connections on section 4. Ensure that the locking pins are inserted fully.
41. Connect a Rigging Rod Connector to each of the fourth Rigging Rods ensuring that the locking pins are inserted fully. Fit the Rigging Rod Connectors into the Rigging Support Brackets on section 4 as shown on page 10.
42. Connect 2 standard rigging rods to the Rigging Rod Connectors. Ensure that the locking pins are inserted fully.
43. Connect 2 Rigging Rod Connectors to the fifth standard rigging rods. Ensure that the locking pins are inserted fully.
44. Connect 2 100cm / 3' 3" rigging rods to the Rigging Rod Connectors and in turn to the rigging connectors on the 100cm / 3' 3" section. Ensure that the locking pins are inserted fully.

45. Hand tighten the rods by turning the turnbuckles until the rods are taut, then secure the turnbuckles with the locking nut as seen on page 9.
Attention: The rigging system when taut as well as the crane arm, should run in a straight line and should not bend or dip.
46. When the Rigging Rods are taut and running in a straight line, insert the locking pin connecting the Rigging Rod Connectors into the Rigging Support Brackets on section 2 and 4 as shown on page 10. Remove the support stand or rostrum supporting the counterweight bucket section.
47. Then unlock the tilt friction.

Before operation, all locking pins, locking screws etc should be inspected to ensure that all assembly sections are securely fastened.

Read “Balancing the crane arm” on page 44.

Version 13

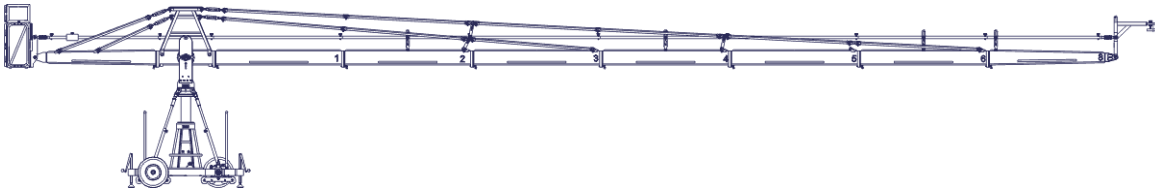

Front extension arms required	7 x 200 cm / 6' 6"
Rear extension arm required	1 x 192 cm / 6' 3"
Lift range	2269 cm / 74' 5"
Maximum Euro-adaptor height	1374 cm / 45'
Lift capacity (working load) camera + accessories	80 kg / 176 lbs
Counterweight required for max. load	1218 kg / 2679 lbs
Counterweight required to balance empty arm	722 kg / 1588 lbs
Crane weight (excluding dolly and weights)	895 kg / 1973 lbs
Dolly weight (unit weights see page 46)	244 kg / 536 lbs
Arm reach (pivot to camera head mount)	1483 cm / 48' 7"
Length of rear end (pivot to outside of bucket)	278 cm / 9' 1"

Continue from § 12, page 6

13. Connect the 200cm / 6' 6" extension number 2 to extension number 1. Slip the connection flanges into each other and secure with the provided safety pin.

Note: Section 2 must be supported by a suitable support stand or rostrum.

Tip: To avoid the sections jamming or getting stuck make sure that the sections are joined parallel. Using a small amount of lubricant also helps. We suggest rubbing the joints with an oiled rag prior to assembly.

14. Connect the 200cm / 6' 6" extension number 3 to extension number 2. Slip the connection flanges into each other and secure with the provided safety pin.

Note: Move the support stand or rostrum to support section number 3.

The "Rigging Harness Assembly" is described on page 9. After reading and following the instructions, please proceed as follows.

15. Connect 2 turnbuckles to the bottom connection on the front side of the rigging harness. Ensure that the locking pins are inserted fully.
16. Connect 2 standard rigging rods to the turnbuckles on the front side of the rigging harness. Ensure that the locking pins are inserted fully.
17. Connect another 2 standard rigging rods to the first 2 rigging rods. Ensure that the locking pins are inserted fully.
18. Connect 2 Rigging Support Brackets to the Rigging Rod Connections on section 2. Ensure that the locking pins are inserted fully.
19. Connect a Rigging Rod Connector to each of the second Rigging Rods ensuring that the locking pins are inserted fully. Fit the Rigging Rod Connectors into the Rigging Support Brackets as shown on page 10.
20. Connect 2 standard rigging rods to the Rigging Rod Connectors and in turn to the rigging connectors on section 3. Ensure that the locking pins are inserted fully.
21. Hand tighten the rods by turning the turnbuckles until the rods are taut, then secure the turnbuckles with the locking nut as seen on page 9.

Attention: The rigging system when taut as well as the crane arm, should run in a straight line and should not bend or dip.

22. When the Rigging Rods are taut and running in a straight line, insert the locking pin connecting the Rigging Rod Connectors into the Rigging Support Brackets on section 3 as shown on page 10.

23. Connect the 200cm / 6' 6" extension number 4 to extension number 3. Slip the connection flanges into each other and secure with the provided safety pin.
24. Connect the 200cm / 6' 6" extension number 5 to extension number 4. Slip the connection flanges into each other and secure with the provided safety pin.
Note: Section 5 must be supported by a suitable support stand or rostrum.
25. Connect the 200cm / 6' 6" extension number 6 to extension number 5. Slip the connection flanges into each other and secure with the provided safety pin.
26. Place a support stand or rostrum under the end of extension number 6. Only remove the support stand or rostrum supporting section 5 provided the support stand or rostrum supporting section 3 is not removed.
27. Connect the Remote Extension to extension number 6. Slip the connection flanges into each other and secure with the provided safety pin.
28. Connect a 200cm / 6' 6" parallelogram rod to the parallelogram connection on the middle section and secure it with the provided safety pin.
29. In turn, connect 5 x 200cm / 6' 6" parallelogram rods to the first parallelogram connection and secure them with the provided safety pins.
Note: Support the second, fourth and sixth parallelogram rod with the parallelogram support located on sections 2, 4 and 6 and secure with the locking pin as shown on page 10.
30. Connect the Remote Extension parallelogram rod to the last 200cm / 6' 6" parallelogram connection and secure it with the provided safety pin.
31. Support the Remote Extension parallelogram rod with the parallelogram support located on the Remote Extension and secure with the locking pin as shown on page 10.
32. Connect the Remote Bracket as described on page 43.
Tip: The Remote Bracket has an integrated leveller. By turning it, the Remote Bracket can be set to a perfect right angle. Correct setting of the angle adjuster enhances the crane's balance.
33. Connect 2 turnbuckles to the top connection on the front side of the rigging harness. Ensure that the locking pins are inserted fully.
34. Connect 2 standard rigging rods to the turnbuckles on the front side of the rigging harness. Ensure that the locking pins are inserted fully.
35. Connect another 2 standard rigging rods to the first 2 standard rigging rods. Ensure that the locking pins are inserted fully.
36. Connect 2 Rigging Support Brackets to the Rigging Support Brackets on section 2. Ensure that the locking pins are inserted fully.
37. Connect a Rigging Rod Connector to each of the second Rigging Rods ensuring that the locking pins are inserted fully. Fit the Rigging Rod Connectors into the Rigging Support Brackets as shown on page 10.
38. Connect another 2 standard rigging rods to the Rigging Rod Connectors on the second 2 standard rigging rods. Ensure that the locking pins are inserted fully.
39. Connect another 2 standard rigging rods to the third 2 standard rigging rods. Ensure that the locking pins are inserted fully.
40. Connect 2 Rigging Support Brackets to the Rigging Rod Connections on section 4. Ensure that the locking pins are inserted fully.
41. Connect a Rigging Rod Connector to each of the fourth Rigging Rods ensuring that the locking pins are inserted fully. Fit the Rigging Rod Connectors into the Rigging Support Brackets on section 4 as shown on page 10.
42. Connect 2 standard rigging rods to the Rigging Rod Connectors. Ensure that the locking pins are inserted fully.
43. Connect 2 Rigging Rod Connectors to the fifth standard rigging rods. Ensure that the locking pins are inserted fully.

44. Connect 2 standard rigging rods to the Rigging Rod Connectors and in turn to the rigging connectors on section 6. Ensure that the locking pins are inserted fully.
45. Hand tighten the rods by turning the turnbuckles until the rods are taut, then secure the turnbuckles with the locking nut as seen on page 9.
Attention: The rigging system when taut as well as the crane arm, should run in a straight line and should not bend or dip.
46. When the Rigging Rods are taut and running in a straight line, insert the locking pin connecting the Rigging Rod Connectors into the Rigging Support Brackets on section 2 and section 4 as shown on page 10.
47. Remove the support stand or rostrum supporting the counterweight bucket section.
48. Then unlock the tilt friction.

Before operation, all locking pins, locking screws etc should be inspected to ensure that all assembly sections are securely fastened.

Read “Balancing the crane arm” on page 44.

Version 14

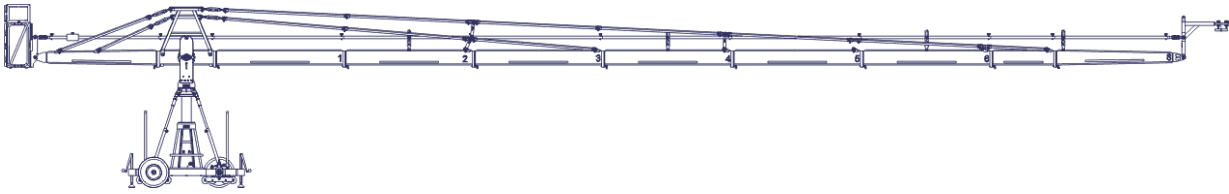

Front extension arms required	7 x 200 cm / 6' 6" + 1 x 100 cm / 3' 3"
Rear extension arm required	1 x 192 cm / 6' 3"
Lift range	2424 cm / 79' 6"
Maximum Euro-adapter height	1452 cm / 47' 7"
Lift capacity (working load) camera + accessories	80 kg / 176 lbs
Counterweight required for max. load	1394 kg / 3066 lbs
Counterweight required to balance empty arm	854 kg / 1878 lbs
Crane weight (excluding dolly and weights)	916 kg / 2019 lbs
Dolly weight (unit weights see page 46)	244 kg / 536 lbs
Arm reach (pivot to camera head mount)	1581 cm / 51' 10"
Length of rear end (pivot to outside of bucket)	278 cm / 9' 1"

Continue from § 12, page 6

13. Connect the 200cm / 6' 6" extension number 2 to extension number 1. Slip the connection flanges into each other and secure with the provided safety pin.

Note: Section 2 must be supported by a suitable support stand or rostrum.

Tip: To avoid the sections jamming or getting stuck make sure that the sections are joined parallel. Using a small amount of lubricant also helps. We suggest rubbing the joints with an oiled rag prior to assembly.

14. Connect the 200cm / 6' 6" extension number 3 to extension number 2. Slip the connection flanges into each other and secure with the provided safety pin.

Note: Move the support stand or rostrum to support section number 3.

The "Rigging Harness Assembly" is described on page 9. After reading and following the instructions, please proceed as follows.

15. Connect 2 turnbuckles to the bottom connection on the front side of the rigging harness. Ensure that the locking pins are inserted fully.
16. Connect 2 standard rigging rods to the turnbuckles on the front side of the rigging harness. Ensure that the locking pins are inserted fully.
17. Connect another 2 standard rigging rods to the first 2 rigging rods. Ensure that the locking pins are inserted fully.
18. Connect 2 Rigging Support Brackets to the Rigging Rod Connections on section 2. Ensure that the locking pins are inserted fully.
19. Connect a Rigging Rod Connector to each of the second Rigging Rods ensuring that the locking pins are inserted fully. Fit the Rigging Rod Connectors into the Rigging Support Brackets as shown on page 10.
20. Connect 2 standard rigging rods to the Rigging Rod Connectors and in turn to the rigging connectors on section 3. Ensure that the locking pins are inserted fully.
21. Hand tighten the rods by turning the turnbuckles until the rods are taut, then secure the turnbuckles with the locking nut as seen on page 9.
- Attention:** The rigging system when taut as well as the crane arm, should run in a straight line and should not bend or dip.
22. When the Rigging Rods are taut and running in a straight line, insert the locking pin connecting the Rigging Rod Connectors into the Rigging Support Brackets on section 3 as shown on page 10.

23. Connect the 200cm / 6' 6" extension number 4 to extension number 3. Slip the connection flanges into each other and secure with the provided safety pin.
24. Connect the 200cm / 6' 6" extension number 5 to extension number 4. Slip the connection flanges into each other and secure with the provided safety pin.
Note: Section 5 must be supported by a suitable support stand or rostrum.
25. Connect the 200cm / 6' 6" extension number 6 to extension number 5. Slip the connection flanges into each other and secure with the provided safety pin.
26. Place a support stand or rostrum under the end of extension number 6. Only remove the support stand or rostrum supporting section 5 provided the support stand or rostrum supporting section 3 is not removed.
27. Connect the 100cm / 3' 3" extension to extension number 6. Slip the connection flanges into each other and secure with the provided safety pin.
28. Connect the Remote Extension to the 100cm / 3' 3" extension. Slip the connection flanges into each other and secure with the provided safety pin.
29. Connect a 200cm / 6' 6" parallelogram rod to the parallelogram connection on the middle section and secure it with the provided safety pin.
30. In turn, connect 5 x 200cm / 6' 6" parallelogram rods to the first parallelogram connection and secure them with the provided safety pins.
Note: Support the second, fourth and sixth parallelogram rod with the parallelogram support located on sections 2, 4 and 6 and secure with the locking pin as shown on page 10.
31. Connect the 100cm / 3' 3" parallelogram rod to the last parallelogram connection and secure it with the provided safety pin.
32. Connect the Remote Extension parallelogram rod to the 100cm / 3' 3" parallelogram connection and secure it with the provided safety pin.
33. Support the Remote Extension parallelogram rod with the parallelogram support located on the Remote Extension and secure with the locking pin as shown on page 10.
34. Connect the Remote Bracket as described on page 43.
Tip: The Remote Bracket has an integrated leveller. By turning it, the Remote Bracket can be set to a perfect right angle. Correct setting of the angle adjuster enhances the crane's balance.
35. Connect 2 turnbuckles to the top connection on the front side of the rigging harness. Ensure that the locking pins are inserted fully.
36. Connect 2 standard rigging rods to the turnbuckles on the front side of the rigging harness. Ensure that the locking pins are inserted fully.
37. Connect another 2 standard rigging rods to the first 2 standard rigging rods. Ensure that the locking pins are inserted fully.
38. Connect 2 Rigging Support Brackets to the Rigging Support Brackets on section 2. Ensure that the locking pins are inserted fully.
39. Connect a Rigging Rod Connector to each of the second Rigging Rods ensuring that the locking pins are inserted fully. Fit the Rigging Rod Connectors into the Rigging Support Brackets as shown on page 10.
40. Connect another 2 standard rigging rods to the Rigging Rod Connectors on the second 2 standard rigging rods. Ensure that the locking pins are inserted fully.
41. Connect another 2 standard rigging rods to the third 2 standard rigging rods. Ensure that the locking pins are inserted fully.
42. Connect 2 Rigging Support Brackets to the Rigging Rod Connections on section 4. Ensure that the locking pins are inserted fully.
43. Connect a Rigging Rod Connector to each of the fourth Rigging Rods ensuring that the locking pins are inserted fully. Fit the Rigging Rod Connectors into the Rigging Support Brackets on section 4 as shown on page 10.

44. Connect 2 standard rigging rods to the Rigging Rod Connectors. Ensure that the locking pins are inserted fully.
45. Connect 2 Rigging Rod Connectors to the fifth standard rigging rods. Ensure that the locking pins are inserted fully.
46. Connect 2 standard rigging rods to the Rigging Rod Connectors. Ensure that the locking pins are inserted fully.
47. Connect 2 Rigging Rod Connectors to the sixth standard rigging rods. Ensure that the locking pins are inserted fully.
48. Connect 2 100cm / 3' 3" rigging rods to the Rigging Rod Connectors and in turn to the rigging connectors on the 100cm / 3' 3" section. Ensure that the locking pins are inserted fully.
49. Hand tighten the rods by turning the turnbuckles until the rods are taut, then secure the turnbuckles with the locking nut as seen on page 9.
Attention: The rigging system when taut as well as the crane arm, should run in a straight line and should not bend or dip.
50. When the Rigging Rods are taut and running in a straight line, insert the locking pin connecting the Rigging Rod Connectors into the Rigging Support Brackets on section 2, 4 and 5 as shown on page 10.
51. Remove the support stand or rostrum supporting the counterweight bucket section.
52. Then unlock the tilt friction.

Before operation, all locking pins, locking screws etc should be inspected to ensure that all assembly sections are securely fastened.

Read "Balancing the crane arm" on page 44.

Version 15

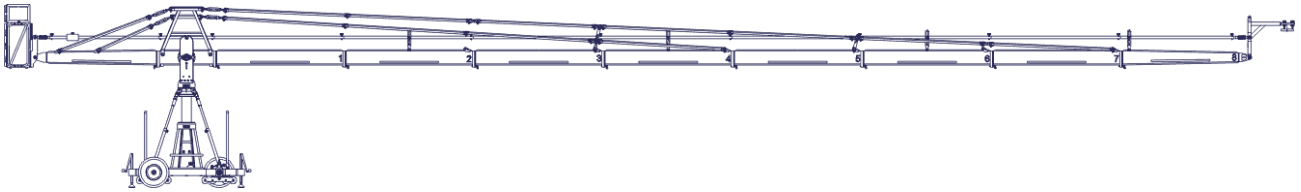

Front extension arms required	8 x 200 cm / 6' 6"
Rear extension arm required	1 x 192 cm / 6' 3"
Lift range	2548 cm / 83' 7"
Maximum Euro-adaptor height	1531 cm / 50' 2"
Lift capacity (working load) camera + accessories	60 kg / 132 lbs
Counterweight required for max. load	1362 kg / 2996 lbs
Counterweight required to balance empty arm	938 kg / 2063 lbs
Crane weight (excluding dolly and weights)	927 kg / 2044 lbs
Dolly weight (unit weights see page 46)	244 kg / 536 lbs
Arm reach (pivot to camera head mount)	1681 cm / 55' 1"
Length of rear end (pivot to outside of bucket)	278 cm / 9' 1"

Continue from § 12, page 6

13. Connect the 200cm / 6' 6" extension number 2 to extension number 1. Slip the connection flanges into each other and secure with the provided safety pin.

Note: Section 2 must be supported by a suitable support stand or rostrum.

Tip: To avoid the sections jamming or getting stuck make sure that the sections are joined parallel. Using a small amount of lubricant also helps. We suggest rubbing the joints with an oiled rag prior to assembly.

14. Connect the 200cm / 6' 6" extension number 3 to extension number 2. Slip the connection flanges into each other and secure with the provided safety pin.

Note: Move the support stand or rostrum to support section number 3.

15. Connect the 200cm / 6' 6" extension number 4 to extension number 3. Slip the connection flanges into each other and secure with the provided safety pin.

The "Rigging Harness Assembly" is described on page 9. After reading and following the instructions, please proceed as follows.

16. Connect 2 turnbuckles to the bottom connection on the front side of the rigging harness. Ensure that the locking pins are inserted fully.
17. Connect 2 standard rigging rods to the turnbuckles on the front side of the rigging harness. Ensure that the locking pins are inserted fully.
18. Connect 2 more standard rigging rods to the first rigging rods. Ensure that the locking pins are inserted fully.
19. Connect 2 more standard rigging rods to the second rigging rods. Ensure that the locking pins are inserted fully.
20. Connect 2 Rigging Support Brackets to the Rigging Rod Connections on section 3. Ensure that the locking pins are inserted fully.
21. Connect a Rigging Rod Connector to each of the third Rigging Rods ensuring that the locking pins are inserted fully. Fit the Rigging Rod Connectors into the Rigging Support Brackets as shown on page 10.
22. Connect 2 standard rigging rods to the Rigging Rod Connectors and in turn to the to the rigging connectors on section 4. Ensure that the locking pins are inserted fully.
23. Hand tighten the rods by turning the turnbuckles until the rods are taut, then secure the turnbuckles with the locking nut as seen on page 9.

Attention: The rigging system when taut as well as the crane arm, should run in a

straight line and should not bend or dip.

24. When the Rigging Rods are taut and running in a straight line, insert the locking pin connecting the Rigging Rod Connectors into the Rigging Support Brackets on section 3 as shown on page 10.
25. Connect the 200cm / 6' 6" extension number 5 to extension number 4. Slip the connection flanges into each other and secure with the provided safety pin.
Note: Section 5 must be supported by a suitable support stand or rostrum.
26. Connect the 200cm / 6' 6" extension number 6 to extension number 5. Slip the connection flanges into each other and secure with the provided safety pin.
27. Place a support stand or rostrum under the end of extension number 6. Only remove the support stand or rostrum supporting section 5 provided the support stand or rostrum supporting section 3 is not removed.
28. Connect the 200cm / 6' 6" extension number 7 to extension number 6. Slip the connection flanges into each other and secure with the provided safety pin.
29. Connect the Remote Extension to extension number 7. Slip the connection flanges into each other and secure with the provided safety pin.
30. Connect a 200cm / 6' 6" parallelogram rod to the parallelogram connection on the middle section and secure it with the provided safety pin.
31. In turn, connect 6 x 200cm / 6' 6" parallelogram rods to the first parallelogram connection and secure them with the provided safety pins.
Note: Support the second, fourth and sixth parallelogram rod with the parallelogram support located on sections 2, 4 and 6 and secure with the locking pin as shown on page 10.
32. Connect the Remote Extension parallelogram rod to the last 200cm / 6' 6" parallelogram connection and secure it with the provided safety pin.
33. Support the Remote Extension parallelogram rod with the parallelogram support located on the Remote Extension and secure with the locking pin as shown on page 10.
34. Connect the Remote Bracket as described on page 43.
Tip: The Remote Bracket has an integrated leveller. By turning it, the Remote Bracket can be set to a perfect right angle. Correct setting of the angle adjuster enhances the crane's balance.
35. Connect 2 turnbuckles to the top connection on the front side of the rigging harness. Ensure that the locking pins are inserted fully.
36. Connect 2 standard rigging rods to the turnbuckles on the front side of the rigging harness. Ensure that the locking pins are inserted fully.
37. Connect another 2 standard rigging rods to the first 2 standard rigging rods. Ensure that the locking pins are inserted fully.
38. Connect a Rigging Rod Connector to each of the second Rigging Rods ensuring that the locking pins are inserted fully.
39. Connect a third Rigging Rod to each of the Rigging Rod Connectors ensuring that the locking pins are inserted fully.
40. Connect 2 Rigging Support Brackets to the Rigging Support Brackets on section 3. Ensure that the locking pins are inserted fully.
41. Connect a Rigging Rod Connector to each of the third Rigging Rods ensuring that the locking pins are inserted fully. Fit the Rigging Rod Connectors into the Rigging Support Brackets on section 3 as shown on page 10.
42. Connect another 2 standard rigging rods to the Rigging Rod Connectors on the third 2 standard rigging rods. Ensure that the locking pins are inserted fully.
43. Connect another 2 standard rigging rods to the fourth 2 standard rigging rods. Ensure that the locking pins are inserted fully.

44. Connect 2 Rigging Support Brackets to the Rigging Rod Connections on section 5. Ensure that the locking pins are inserted fully.
45. Connect a Rigging Rod Connector to each of the fifth Rigging Rods ensuring that the locking pins are inserted fully. Fit the Rigging Rod Connectors into the Rigging Support Brackets on section 5 as shown on page 10.
46. Connect 2 standard rigging rods to the Rigging Rod Connectors. Ensure that the locking pins are inserted fully.
47. Connect 2 Rigging Rod Connectors to the sixth standard rigging rods. Ensure that the locking pins are inserted fully.
48. Connect 2 standard rigging rods to the Rigging Rod Connectors and in turn to the rigging connectors on section 7. Ensure that the locking pins are inserted fully.
49. Hand tighten the rods by turning the turnbuckles until the rods are taut, then secure the turnbuckles with the locking nut as seen on page 9.

Attention: The rigging system when taut as well as the crane arm, should run in a straight line and should not bend or dip.
50. When the Rigging Rods are taut and running in a straight line, insert the locking pin connecting the Rigging Rod Connectors into the Rigging Support Brackets on section 3 and section 5 as shown on page 10.
51. Remove the support stand or rostrum supporting the counterweight bucket section.
52. Then unlock the tilt friction.

Before operation, all locking pins, locking screws etc should be inspected to ensure that all assembly sections are securely fastened.

Read “Balancing the crane arm” on page 44.

Remote Head Mount

1. The Remote Head Mount is connected to the remote “nose” section.

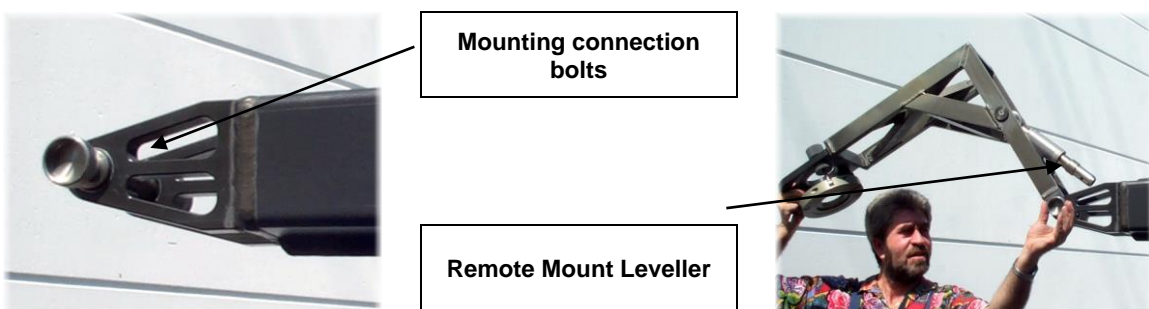

2. Connect the Remote Mount to the connection bolts on the nose section and lock securely.
3. Connect the Remote Mount Leveller to the Remote Parallelogram rod.
4. Secure the Remote Mount Leveller to the Remote Parallelogram rod by inserting the locking pin. Level the Remote Mount as needed.



Balancing the crane arm



Attention: When loading the crane the maximum working load capacities and payloads must never be exceeded.

Note: Do not load weights until the rigging system is mounted.

After the assembly procedure has been completed the seat arms, seats, risers, camera etc may now be assembled on the platform or the remote head system may be mounted. **An itemized weight list for GFM accessories may be found below.** Place the correct amount of counterweight in the weight bucket to balance the load. The counterweights should not be thrown into the bucket but rather placed softly in the bucket. When the arm is balanced, the camera operator / operators can then take their position on the platform.



Attention: The safety belts provided must be fastened upon sitting down and kept fastened at all times when on the platform.

Only original GFM seats, seat arms, risers etc may be used.

Working load capacity = Camera operator / operators + accessories

Place the required amount of counterweights in the weight bucket so that the crane arm becomes balanced and remains in the horizontal position. If necessary, the crane can be fine balanced by adjusting the sliding weight on the rear parallelogram at the weight bucket. Do not forget to lock the sliding weight in position before tilting the arm. The counterweight bucket door must be locked when operating the crane.

Deloading:



Attention: When dismantling the crane it is essential that the platform is supported fully by a stable underlay i.e. rostrum or ground surface. In any case the platform should not be in the air without support.



Attention: The counterweights must always be gradually removed from the counterweight bucket before personnel leave the platform.

When the weights are removed, the platform personnel should dismount one at a time but only after being instructed to do so by the crane operator. At all times, extreme caution must be given to the shifting payload.

General Safety



Attention: All necessary precautions should be taken so that unauthorized third parties cannot use or operate the crane and also to ensure that only authorized personnel have access to it.

Operational conditions:

At a wind speed of 25 km/h – 15.6 mph crane operation must be stopped and the crane secured, dismantled and the necessary safety precautions taken.

If it, for example, takes 2 mins. to unload the counterweights and take the necessary precautions to secure the crane, one must commence with the procedure at a wind speed of 20 km/h – 12.4 mph. DIN15019, part 1, section 6.13.

The crane may not be used in a lightening storm as there is the danger of electrocution.

Positioning the Adjustable Mounting Column

1. When the crane is assembled, the Adjustable Mounting Column may be driven to it's full height. The column may either be hand cranked or driven with a 24V battery driven screwdriver. We suggest you drive the screwdriver at speed 1. The connection on the column is a 24mm, male hexagonal head.



Important: When adjusting the height of the column make sure that the 4 Adjustable Stabilizing Rods can move freely and that they are not restricted in travel. The Rod Locking Pin found in the middle of each rod must be removed when adjusting the height and reinserted only when the column is in the required position.



Rod Locking Pins



STOP Mark

Rod Locking Nut



Important: When driving the column upwards, do not go past the "STOP" mark engraved on the column.

2. When the column is in the required position, insert the 4 Rod Locking Pins into the middle of each rod. Adjust the 4 rods until they are stiff, then counter lock with the locking nuts found at end of each stabilizing rod (total of 8).

GF-16 Camera Crane and Dolly Dimensions

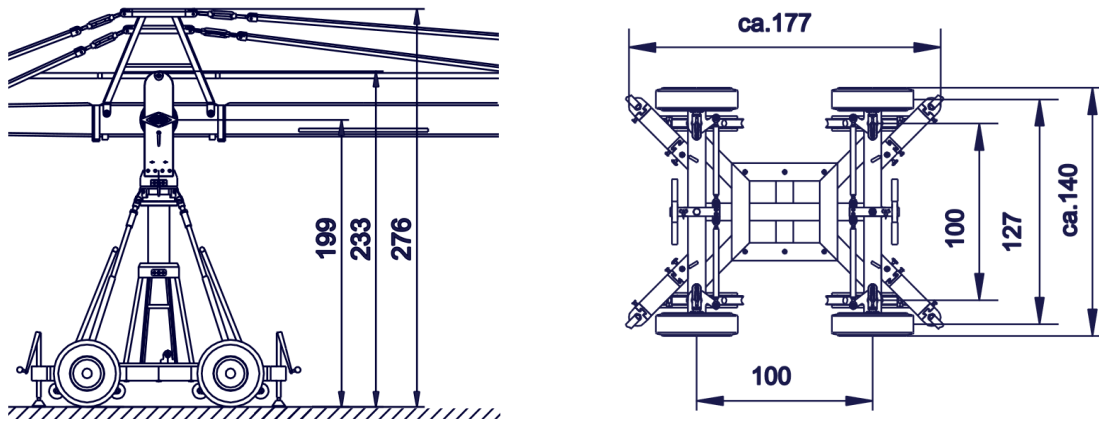

Dolly weight

Description	Weight kg	Weight lbs
Dolly Base	186 kg	410 lbs
Levelling leg set (4 pcs.)	28 kg	61 lbs
Track wheel set (4 pcs.)	24 kg	53 lbs
Base Dolly push bar	6 kg	13 lbs
Complete Dolly weight	244 kg	536 lbs
Adjustable Mounting column with rotateable bearing	136 kg	300 lbs
Stabilizing rod set (4 pcs.)	11 kg	24 lbs

Accessories for GF- 16 crane



Track wheel with brake



Levelling leg



Push bar



Utensil tray

Notice:

When operating the crane with the **push bar** mounted on the dolly, pay attention that the crane arm at no time collides with the push bar.

Always use the levelling legs to level the crane when on uneven surfaces. For safety reasons only original accessories manufactured by GFM may be used with the crane.

Accessories for GF-16 Crane platform weight list

Qty.	Description		Weight kg	Weight lbs
1	Seat arm combined 10cm / 4"	AL-2210	0,75 kg	1,65 lbs
1	Seat arm combined 20cm / 8"	AL-2220	1,15 kg	2,53 lbs
1	Seat arm combined 30cm / 12"	AL-2230	1,60 kg	3,52 lbs
1	Seat arm vertical 10cm / 4"	AL-2211	1,25 kg	2,75 lbs
1	Seat arm vertical 20cm / 8"	AL-2212	1,75 kg	3,85 lbs
1	Seat arm vertical 30cm / 12"	AL-2213	2,20 kg	4,84 lbs
1	Crane seat with seat belt	AL-1030	7,20 kg	15,84 lbs
1	Riser 10 cm / 4"	AL-2310	2,80 kg	6,16 lbs
1	Riser 20cm / 8"	AL-2320	2,95 kg	6,49 lbs
1	Riser 30cm / 12"	AL-2330	3,40 kg	7,48 lbs
1	Riser 40cm / 16"	AL-2340	3,80 kg	8,36 lbs
1	Riser 50cm / 20"	AL-2350	4,25 kg	9,35 lbs
1	Connection pin	AL-2240	0,40 kg	0,88 lbs
1	Ball Adapter	AL-2150	2,17 kg	4,77 lbs

Transport trolley for the GF-16 Crane



The above photos show the practical transport solution for the GF-16 Crane System. The GFM trolley fits the complete system with dolly and column as an extra unit.



Attention: After loading and unloading the GF-16 Crane System the wheel brakes have to be locked.

Maintaining the Adjustable Column

The GF-16 Crane has an adjustable column which provides a vertical lift of 400mm. This lift is achieved through an elevating gear which should be inspected at regular yearly intervals.

In general, maintenance work should only be carried out by competent personnel, observing at all times the safety regulations and recognized safety guidelines. After using the column we recommend cleaning it with WD40.

Dismantling the column:

The column should be dismantled as per the following steps:

1. Remove the adjustable stabilizing rods and in turn remove the column (see page 4).
2. Remove the rotateable bearing by opening the bolts.



3. Extend the column until the STOP mark is visible. Using extreme caution, lay the column on its side (attention, danger of damaging the column).
4. Dismantling the drive shaft.

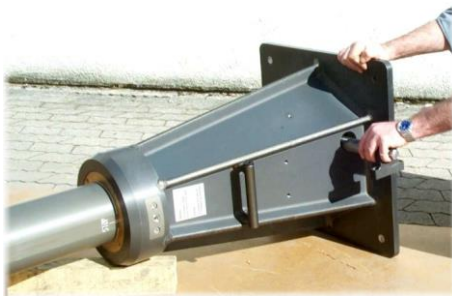

5. Remove the plastic cover which protects the friction and release the friction.
6. Remove the 8 bolts at the bottom of the ground plate.



7. Remove the spindle unit through the bottom of the column (extreme care should be taken to not damage the spindle).

Maintenance

At yearly intervals, the spindle must be cleaned and all grease removed and replaced with generous quantities of fresh grease (e.g. gleitmo 805, gleitmo 585M, Fa. Fuchs Lubritech GmbH).

The lubricating nipple on the lift gear (bright green) must also be greased yearly (e.g. Mobil grease XHP).



Wear and tear on the spindle nut must also be annually inspected. This can be done as per in the above picture by moving the components against each other. If there is more than 2mm of play, the spindle drive or the spindle nut must be replaced otherwise further use is not allowed.



Attention: Danger of crushing while tilting the column and sliding it to check the wear and tear.

When reassembling the column it should be noted that the friction should only be screwed in so far as to allow it move up and down easily and reduce any rotation of the column. Furthermore, when operating the column pay close attention to the ease of movement and any changes that occur in the movement.



Attention: For safety reasons only original spare parts by GFM may be used for maintenance and reparation!

Regular Inspections

According to guideline DGUV regulation 17, § 34, repeated inspections by a technical expert must be carried out at least once every year. In addition, inspection through a technical expert, based on the scope of examination must be carried out every 4 years. The inspections must be registered in the Log Book that is delivered with each crane.

Technical experts must meet the requirements of DGUV regulation 17, § 34 and § 36 according to the following explanation:

A technical expert for the annual inspection is a person who, based on their training and experience has sufficient knowledge in:

- Areas of technical safety and machinery as well as the State's related protective regulations for the work place.
- Rules and regulations from the respective government safety organization.
- Recognized regulations and generally recognized technical rules and accepted technical codes of practice (e.g. DIN norms, VDE regulations, technical rules of other European Union members States or other States that comply with the Treaty on the European Economic Area)
- Work related safety standards and technical safety for machinery.

Valid as a technical expert for the inspection of technical safety and machine facilities every 4 years is an expert recognized by the government safety organization. In general, the authorisation of a recognized technical expert requires the following:

- a) Completed studies as an Engineer
- b) A minimum of 3 years experience in construction design, assembly or maintenance of safety relevant and technical facilities.

It is recommended that the safety inspections be carried out by GFM or a local recognized expert.

Contact details of domestic and foreign technical experts can be obtained from recognized technical surveillance organizations (e.g. TÜV).

EC Declaration of Conformity

The company **Grip Factory Munich GmbH**
Fürholzener Str. 1
D-85386 Eching

declares, that the crane Type: GF-16
 Model: Cameracrane
 Serial No. and year of manufacturing:
 see identification plate

complies with the machine guidelines 2006/42/EG

Safety Type Tested by: TÜV SÜD Industrie Service GmbH
 Westendstr. 199
 80686 München - Deutschland

Safety Type Test report no.: EG-MRL 065

Certification body for lifts cranes no.: 0036

This EC Declaration of Conformity will become invalid should the crane be in any way modified and the modifications not be authorized by us in writing.

Eching, March 2015

Paolo Tundo - Director of company